



# TSUBAKI CAM CLUTCH

## TSUBAKI offers the most complete and versatile selection of one-way clutches in the industry.

Cam Clutches are precision devices which lock the inner and outer races, through the wedging action of cams, to transmit torque in one direction of rotation; and overrun in the opposite direction. These units are often referred to as freewheels, sprags, overrunning, backstop or one-way clutches, depending upon their application.

### Design Features

#### Full Cam Complement



The full complement of cams provide the maximum number of load transmitting members per given diameter. The result is a greater torque capacity size-for-size than other clutches.



#### Cam Design

Precision formed cams made of a special alloy steel provide extra long wear and fatigue life.

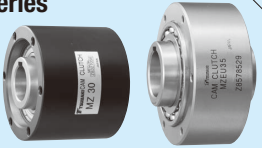
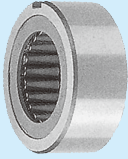
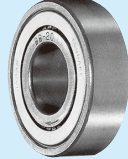

#### High Quality Components

The clutch races are made of high-quality alloy steel with high surface hardness and core toughness. The races are precision ground, provide excellent concentricity and surface finish to obtain accurate cam rotation.

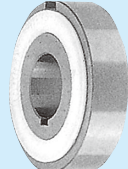
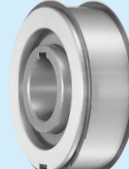
<p><b>MZ, MZ-G, MZEU Series</b></p>  <p>Page 22 to 30</p>	<p><b>200 Series</b></p>  <p>Page 31</p>	<p><b>BB Series</b></p>  <p>Page 32 33</p>	<p><b>TSS Series</b></p>  <p>Page 34</p>
<p>MZ Series clutch is prelubricated with a special grease and requires no lubrication maintenance. Ideal for general applications. The outer race of the MZ-G series is machine finished. MZEU series clutch is European style model.</p>	<p>200 Series clutch is shaft-mounted and prelubricated with special grease. The shaft must be supported by two bearings.</p>	<p>BB series clutch has the bearing characteristics and dimensions of #62 type ball bearing. This design provides easy handling and installation. Ideal for general applications.</p>	<p>TSS series clutch is designed for press fit installation. Outside dimensions are the same as series 62 ball bearings. This design provides easy handling and installation, ideal for general applications.</p>
<p><b>MZ:</b> Bore Range: <math>\phi 15</math> to <math>\phi 70</math> mm Torque Range: 186 to 3040 N-m <b>MZ-G:</b> Bore Range: <math>\phi 15</math> to <math>\phi 70</math> mm Torque Range: 186 to 3040 N-m <b>MZEU:</b> Bore Range: <math>\phi 12</math> to <math>\phi 150</math> mm Torque Range: 60 to 33800 N-m</p>	<p><b>Bore Range: <math>\phi 16.5</math> to <math>\phi 79.3</math> mm</b> <b>Torque Range: 39 to 1390 N-m</b></p>	<p><b>Bore Range: <math>\phi 15</math> to <math>\phi 40</math> mm</b> <b>Torque Range: 29 to 260 N-m</b></p>	<p><b>Bore Range: <math>\phi 8</math> to <math>\phi 60</math> mm</b> <b>Torque Range: 6 to 649 N-m</b></p>

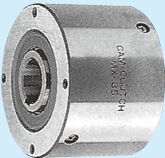
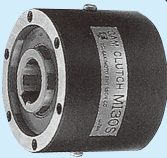
<p><b>TFS Series</b></p>  <p>Page 35</p>	<p><b>PB Series</b></p>  <p>Page 36</p>	<p><b>LD Series</b></p>  <p>Page 37</p>	<p><b>MDEU Series</b></p>  <p>Page 38</p>
<p>TFS series clutch is designed for press fit installation. TFS has two vertical keyways on the outer race. Outside dimensions are the same as series 63 ball bearings. This design provides easy handling and installation, ideal for general applications.</p>	<p>PB Series clutch is packed with a special grease for general applications. The outer race has provision for mounting gears, pulleys, and sprockets.</p>	<p>LD Series clutch is packed with a special grease and requires no lubrication maintenance. This model is easily installed and ideal for light-duty applications.</p>	<p>MDEU series clutch is European style model. Bearing is unnecessary due to cam and roller construction. Easy installation for sprocket, pulley or gear by using the Spirolox on the outer race. This enables to omit to make the flange for sprocket, pulley or gear, ideal for medium duty applications.</p>
<p><b>Bore Range: <math>\phi 12</math> to <math>\phi 80</math> mm</b> <b>Torque Range: 18 to 3924 N-m</b></p>	<p><b>Bore Range: <math>\phi 10</math> to <math>\phi 45</math> mm</b> <b>Torque Range: 29 to 2110 N-m</b></p>	<p><b>Bore Range: <math>\phi 10</math> to <math>\phi 30</math> mm</b> <b>Torque Range: 5 to 49 N-m</b></p>	<p><b>Bore Range: <math>\phi 15</math> to <math>\phi 80</math> mm</b> <b>Torque Range: 70 to 2300 N-m</b></p>

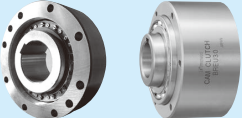
<b>MX Series</b> 	Page 39 <b>MI-S Series</b> 
MX Series clutch is best suited for indexing applications. This model ensures long life and accurate intermittent motion at the driven race.	MI-S Series has special surface-treated cams for use in large feed angle indexing applications.
<b>Bore Range: ø22 to ø70 mm</b> <b>Torque Range: 78 to 784 N-m</b>	<b>Bore Range: ø20 to ø30 mm</b> <b>Torque Range: 43 to 196 N-m</b>

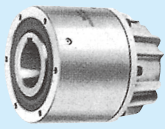
<b>BS, BS-F, BS-R, BSEU Series</b> 	Page 41 to 53 <b>BR-HT, BR-P, BREU Series</b> 	Page 67 to 68 <b>MG, MI, MR Series</b> 	Page 69 <b>MG-R Series</b> 
BS Series clutch is exclusively used in backstop applications for conveyors and bucket elevators. BSEU series clutch is European style model. BS-F Series offer higher torque and speed.	BR-HT Series clutch is mainly used as backstop of inner race high-speed over running. BR-P Series is the BR Series with the bearings, BREU series clutch is European style model.	MG Series clutch is used for low to medium speed inner race overrunning. MI Series is for indexing applications. MR Series is for outer race highspeed overrunning applications.	MG-R Series clutch with oil reservoir can be used in backstop service of inner race continuous and medium-speed overrun.
<b>BS,BS-F:</b> Bore Range: ø20 to ø465 mm Torque Range: 294 to 980000 N-m <b>BS-R:</b> Bore Range: ø40 to ø450 mm Torque Range: 1570 to 686000 N-m <b>BSEU:</b> Bore Range: ø20 to ø90 mm Torque Range: 216 to 4700 N-m	<b>BR-HT:</b> Bore Range: ø20 to ø320 mm Torque Range: 105 to 366000 N-m <b>BR-P:</b> Bore Range: ø20 to ø240 mm Torque Range: 306 to 62034 N-m <b>BREU:</b> Bore Range: ø30 to ø150 mm Torque Range: 607 to 33908 N-m	<b>MG MI:</b> Bore Range: ø19 to ø250 mm Torque Range: 314 to 176000 N-m <b>MR:</b> Bore Range: ø85 to ø160 mm Torque Range: 9510 to 33800 N-m	<b>Bore Range: ø19 to ø250 mm</b> <b>Torque Range: 314 to 176000 N-m</b>

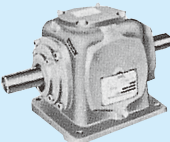
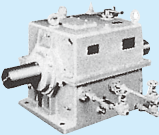
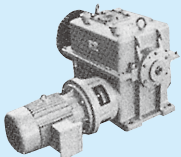
<b>MZ-C, MG-C Series</b> 	Page 70 <b>OB-ON,OF Series</b> 	Page 71 to 72 <b>OB-SF, SN, S, PN, PF Series</b> 	Page 73 to 75 <b>TB Series</b> 												
MZ-C Series clutch is clutch coupling utilizing MZ Series clutch. MG-C Series clutch is clutch coupling utilizing MG Series clutch.	OB-ON Series is enclosed unit containing Cam Clutch and shafts. They can be used for high-speed and continuous overrunning applications. Lubrication is by oil bath.	These are enclosed units containing Cam Clutch and shafts, and are used for high-speed and continuous overrunning applications. The lubrication methods are:	TB Series is enclosed unit containing Cam Clutch and worm gear reducer for turning and inching applications.												
<b>MZ-C:</b> Bore Range: ø20 to ø70 mm Torque Range: 323 to 3040 N-m <b>MG-C:</b> Bore Range: ø19 to ø160 mm Torque Range: 314 to 33800 N-m	<b>Torque Range: 314 to 5880 N-m</b>	<table border="1" data-bbox="821 1951 1141 2085"> <tr> <td>SF</td> <td>Self-lubrication with fins for water cooling</td> <td>S</td> <td>External forced lubrication</td> </tr> <tr> <td>SN</td> <td>Self-lubrication</td> <td>PN</td> <td>Oil bath</td> </tr> <tr> <td>PF</td> <td>Oil bath Water cooling</td> <td></td> <td></td> </tr> </table> <b>Torque Range: 3140 to 40200 N-m</b>	SF	Self-lubrication with fins for water cooling	S	External forced lubrication	SN	Self-lubrication	PN	Oil bath	PF	Oil bath Water cooling			<b>Torque Range: 3140 to 24500 N-m</b> <b>Motor Capacity: 0.75 to 22 kW</b> <b>Reduction Range: 10:1 to 60:1</b>
SF	Self-lubrication with fins for water cooling	S	External forced lubrication												
SN	Self-lubrication	PN	Oil bath												
PF	Oil bath Water cooling														

## Taking Advantage of Differences in Rotating Direction and Speed... TSUBAKI Cam Clutches

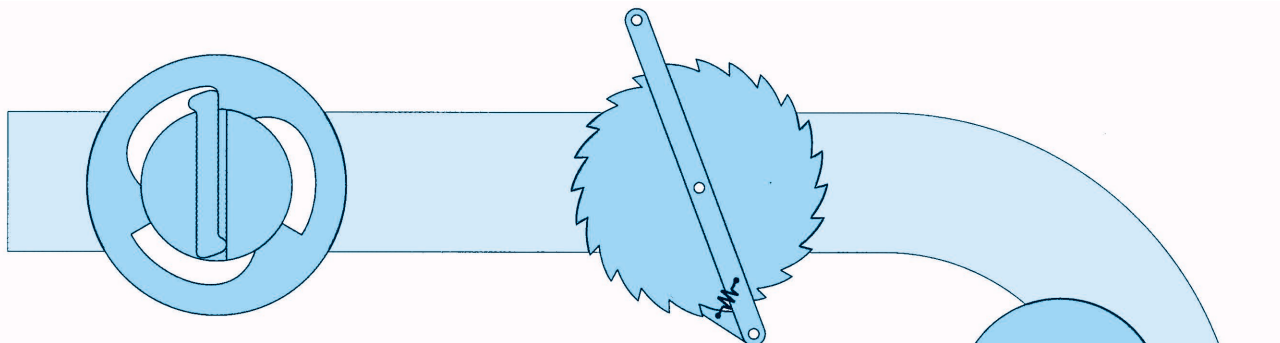

One-way clutches are efficient mechanical devices that utilize differences in axial rotating direction and the speed of rotation to prevent reverse rotation and ensure safety. In order to create a more reliable uni-directional clutch, engineers have spent many years developing and improving clutches, from the simple prop type, to the ratchet type and the roller type, and then culminating to the Cam Clutch, which has become the mainstream. The TSUBAKI Cam Clutch introduced here is a cam-type, one-way clutch that is the leading clutch of today.

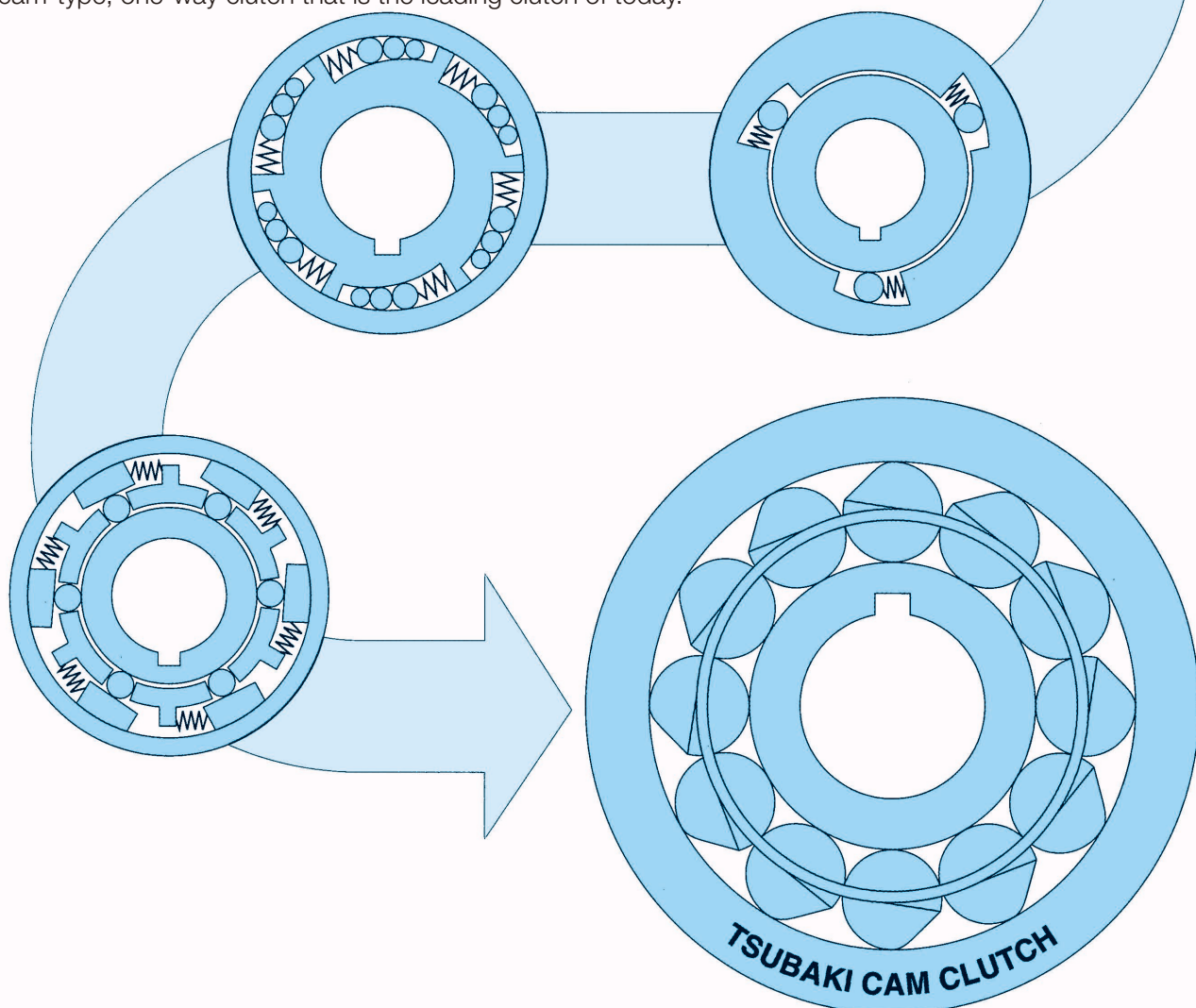

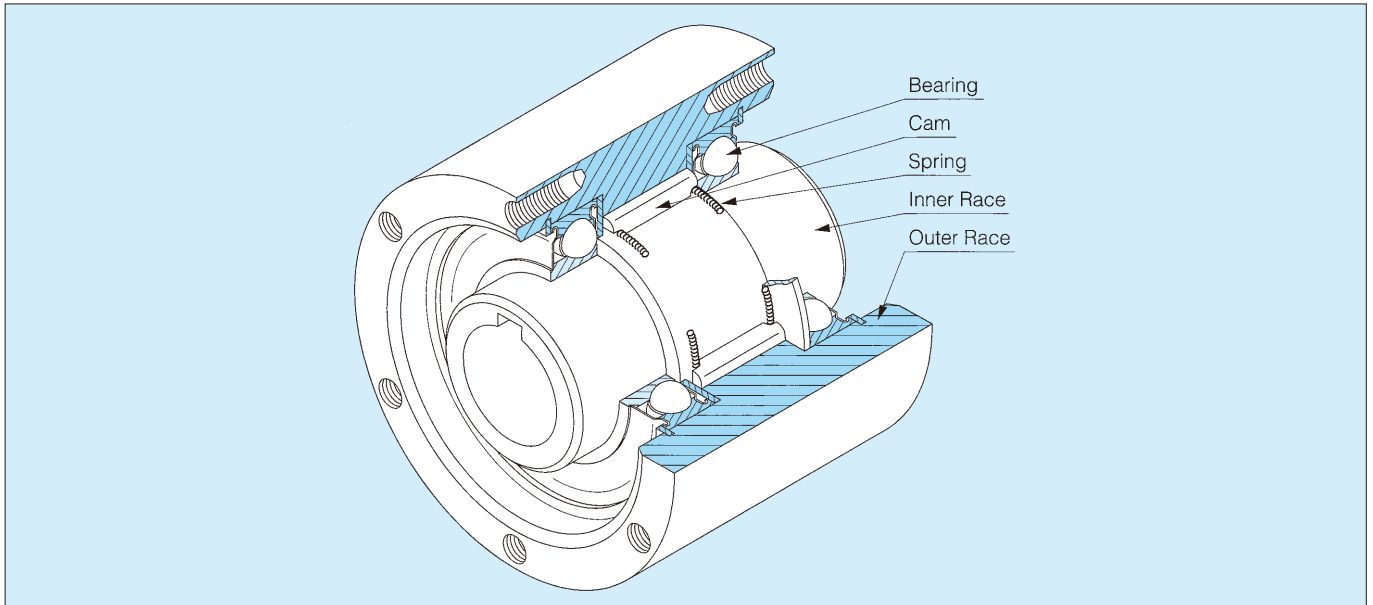

## ■ STANDARD SPRAG TYPE CAM CLUTCH CONSTRUCTION

The figure shows a typical model from the MZ Series for explaining construction.

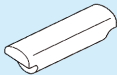
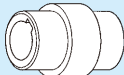
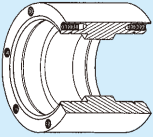

### Major Component Parts

The major parts of the Cam Clutch are the cams, inner race, outer race, springs and bearings. Each of these parts play an important role in the function of the Cam Clutch. All parts are made of carefully selected materials, have undergone appropriate heat treatment, and have passed strict quality control checks.

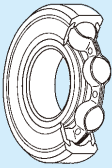
Part	Appearance	Function
Cam		A number of cams set regularly in between the inner and outer races function as props or sliders depending on the relative rotating directions of the inner and outer races. This action causes engagement (clutching) and disengagement (overrunning) of the clutch inner and outer races. The cams are the vital component of a Cam Clutch, and they are available in various models and types to suit a variety of applications.
Inner Race		The inner and outer sliding faces of the races are hardened and precision-ground into a perfectly round cylinder to enable them to withstand the compressive stress generated during engagement with the cam and sliding abrasion when overrunning.
Outer Race		
Spring		Compressed springs are set at both ends of the cams to ensure that all of the cams contact the inner and outer races at all times. Thus, the cams are always ready for immediate engagement. This is extremely important so as to ensure that the load is spread evenly across all cams when they engage with the inner and outer races.
Bearing		The bearings maintain concentricity of the inner and outer races and bear the radial load for the engagement of the cams and the inner and outer races. Maintaining concentricity is particularly important to ensure that the load is spread equally and simultaneously over the cams at the time of engagement.

## ■ BR-HT SERIES CONSTRUCTION

BR-HT Cam Clutch is High Torque version of existing BR series.

BR-HT is mainly used in backstop application for the inner race high-speed overrunning.

Prevention of reverse rotation for inclined conveyor and bucket elevator are typical application examples.

BR-HT assures not only the immediate backstop function under the high torque, but also the long service life by the "Lift-Off" design.

In addition installation on the high speed shaft with low torque enables selection of more compact models with resulting lower cost.

We can offer the most appropriate model from wide range of size according to your needs.

### Non-contact design extends service life

#### Greatly Increased Service Life

Made possible by TSUBAKI's extensive experience in mechanical power transmission, the cam used in BR-HT Cam Clutch offers a unique cross section that provides positive mechanical engagement only when needed. Otherwise, the Cam Clutch rotates freely with absolutely no mechanical contact in the clutch mechanism. The result is a greatly increased service life compared to conventional types.

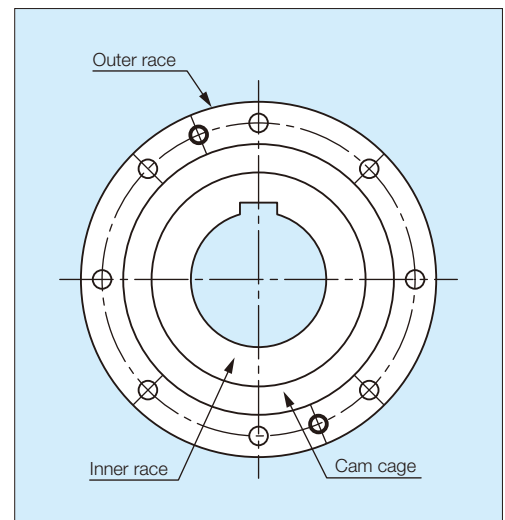
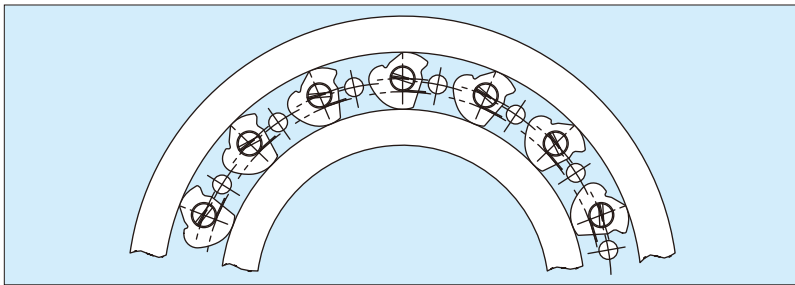

#### Backstop applications for high-speed overrunning

When the Cam Clutch is stationary, the cam locks the inner and outer races together. When the inner race (load side) overruns at a high speed, the cam disengages by releasing from the inner race (figure 1). When the inner race stops, the cam rotates back into an engaged position. If the inner race tries to rotate in the reverse direction, the cams then serve as prop between the anchored outer race and inner race to prevent the reverse rotation and provide backstopping.

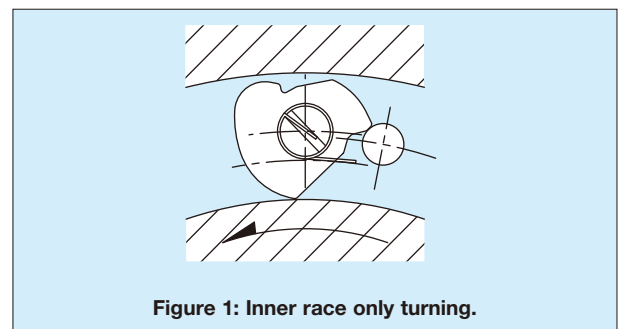

#### A more economical design

BR-HT series features a simple design in which the Cam Clutch mechanism is incorporated in a cage between standard dimension inner and outer bearing races. This allows the Cam Clutch to be easily and economically integrated into a wide variety of mechanical systems.

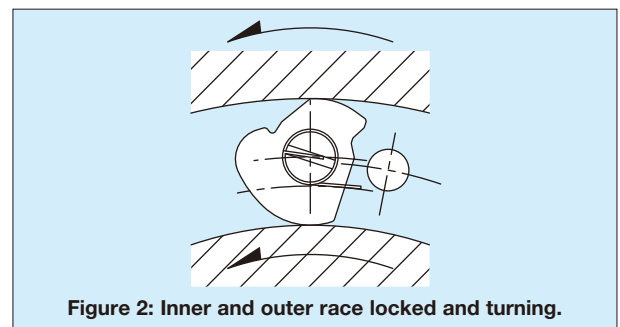

## ■ MODES OF OPERATION

TSUBAKI Cam Clutches are precision devices which lock to transmit torque in one direction of rotation, but overrun (freewheel) in the opposite direction of rotation. All the series of clutches utilize the same principles of operation. Since clutch applications encompass a variety of load and speed characteristics, TSUBAKI Cam Clutches are manufactured in a range of capacities and styles, which are designed to provide the best functional characteristics for performing in the following three basic modes of operation:

### 1. General overrunning

Clutches used in this type of application overrun at either the inner or outer race during the majority of the clutch operating time, and are occasionally called upon to lock up and drive. A typical application is a two-speed drive, where an electric motor and a geared motor are connected to a single driven shaft through one-way clutches. The machine can be driven by either the electric motor or geared motor. When the geared motor drives at low speed, the clutch engages. When the electric motor drives the machine, the clutch overruns. The clutch automatically switches between low speed and high speed.

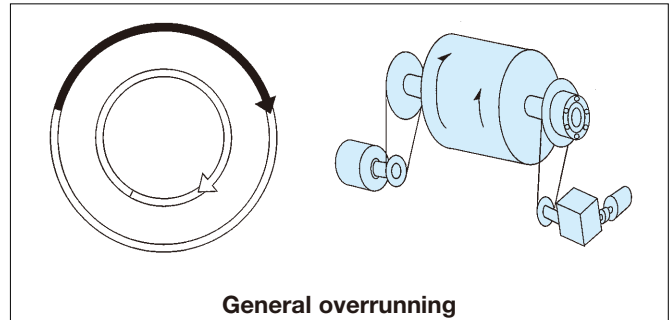

### 2. Indexing

In this mode of operation, reciprocating motion applied to the driving race of the clutch is transformed into unidirectional intermittent motion, at the driven race. For example, on a feeding roller, the clutch is mounted on the roller and a torque arm is connected to the driving race of the clutch. A crank motion mechanism provides reciprocating motion to the driving race. The clutch drives in the forward stroke (index) and overruns on the return stroke, resulting in intermittent unidirectional motion of the feeding roller.

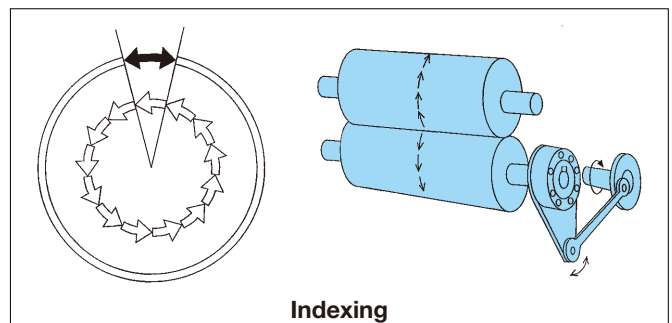

### 3. Backstopping

In backstop applications, the clutches are used to prevent reverse rotation of drive shafts, which may cause damage to machinery and other expensive equipment. With the outer race of the clutch anchored stationary, the inner race can overrun freely in one direction of rotation. Reverse rotation is instantaneously prevented by the automatic engagement of the clutch. Typical backstop applications are in conveyor systems and gear reducers.

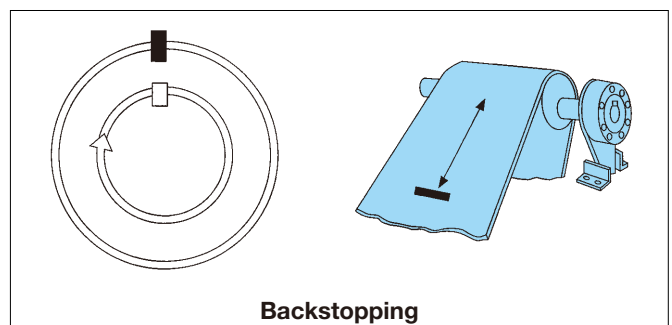

## Typical Applications

Air cleaning plants  
Agricultural machines  
Bucket elevators  
Compressors  
Conveyors  
Cranes and hoists  
Dry cleaning machinery  
Duplicator equipment  
Fish net machines

Heat-treatment furnaces  
Induced draft fans  
Multi-state conveyors  
Packaging machinery  
Printing machinery  
Pumps  
Punch presses and feeders  
Power plants

Refinery equipment  
Speed reducers  
Standby power units  
Textile looms  
Two-speed grinders  
Two-speed shiftovers  
Washing machines  
Wire winding machinery

# CAM CLUTCH SELECTION CHART

## Classification of Applications

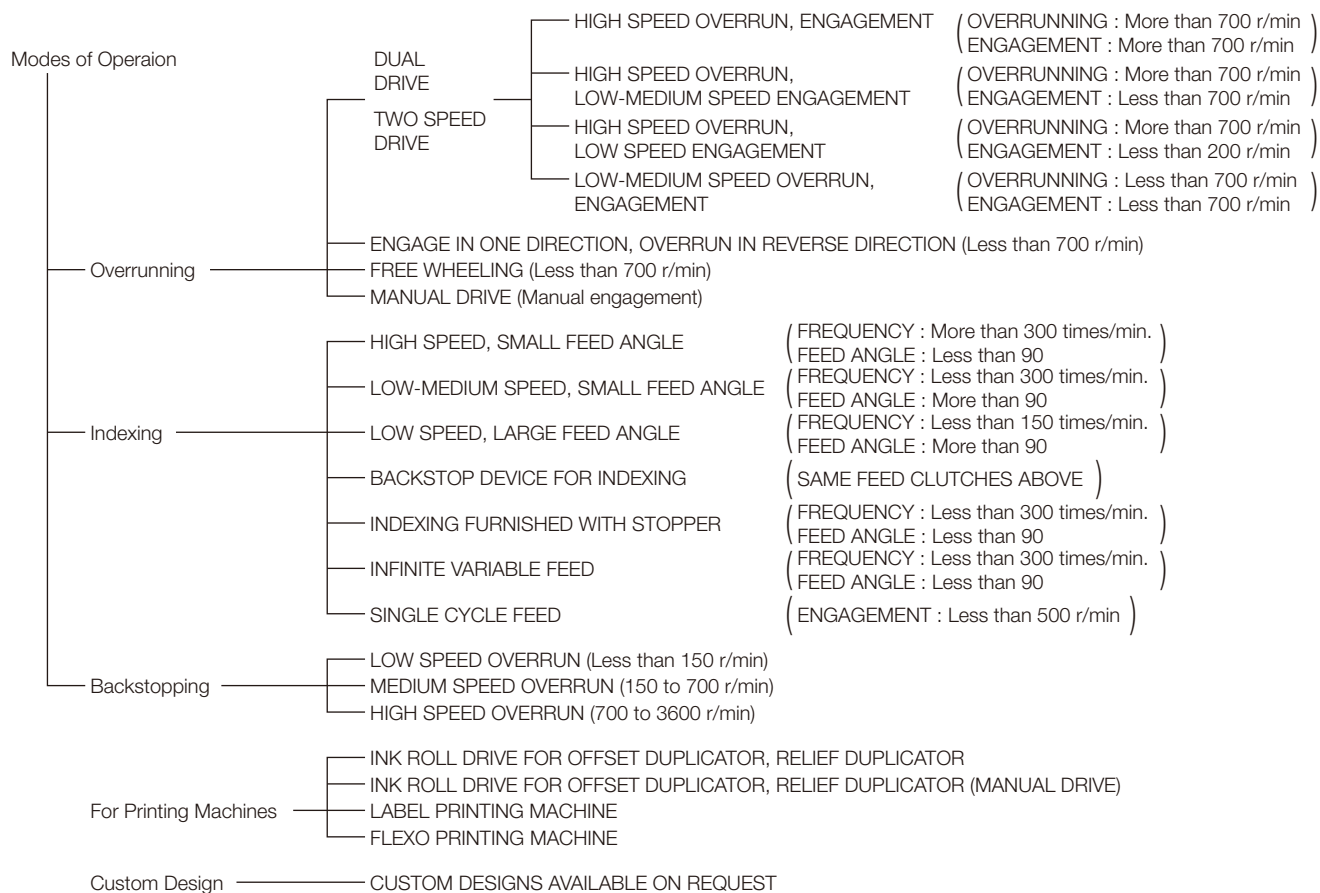

## Series Selection

○ : SUITABLE ◎ : MOST SUITABLE

APPLICATION		SERIES	MZ(G)	MZEU	200	BB	TFS/TSS	PB	LD	MDEU	MX	M-S	BS BS-F	BS-R	BSEU	BR-HT BR-P	BREU	MG	MI	MR	MG-R	MZ-C	MG-C	OB-ON,SF SN,S,PN,PF	TB		
DUAL DRIVE	HIGH SPEED OVERRUN, ENGAGE		○	○																			○		◎		
	HIGH SPEED OVERRUN, LOW MEDIUM SPEED ENGAGE		◎	○																	◎		◎		◎		
TWO SPEED DRIVE	HIGH SPEED OVERRUN, LOW SPEED ENGAGE		◎	○												◎	◎			◎		◎		◎	◎	◎	
	LOW-MEDIUM SPEED OVERRUN, ENGAGE		◎	◎	○	○	○	○	○	○	○							○					◎	○			
ENGAGE IN ONE-WAY DIRECTION, OVERRUN IN REVERSE DIRECTION			◎	◎	○	○	○	○	○	○								○	○				◎	○			
FREE WHEELING			◎	◎	○	○	○	○	○	○								○	◎				◎	○			
MANUAL DRIVE			○	○	○	○	○	○	◎	○													○				
<b>Indexing</b>																											
HIGH SPEED, SMALL FEED ANGLE												◎															
LOW-MEDIUM SPEED, SMALL FEED ANGLE			○	○	○	○	○	○	○	○	○	○														◎	
LOW SPEED, LARGE FEED ANGLE												◎															
BACKSTOP DEVICE FOR INDEXING			○	○	○	○	○	○	○	○	○	◎	◎														
INDEXING FURNISHED WITH STOPPER		PLEASE CONTACT TSUBAKI																									
INFINITE VARIABLE FEED			○	○	○	○	○	○	○	○		◎								○							
<b>Backstopping</b>																											
LOW SPEED OVERRUN			○	○	○	○	○	○	○	○			◎	◎	◎				○								
MEDIUM SPEED OVERRUN			○	○	○	○	○	○											○				◎				
HIGH SPEED OVERRUN			○	○		◎	○									◎	◎									○	
CUSTOM DESIGN		CUSTOM DESIGNS AVAILABLE ON REQUEST																									

# USE IN VARIOUS APPLICATIONS

To select the optimum Cam Clutch, it is imperative that you thoroughly understand the application and conditions of use. The following explains the use of Cam Clutches by application: First confirm how the clutch you are going to use is classified, and then obtain detailed data from the relevant pages.

## A. OVERRUNNING

### Cam behavior and Cam Clutch operation

In the case of a Cam Clutch similar to the one shown on the right, the different conditions of engagement and disengagement for the various possible states are described below. These states are referred to as "overrunning".

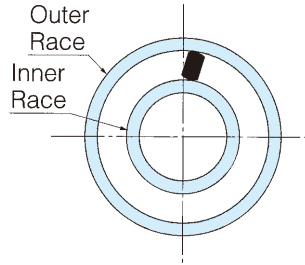

#### 1. Outer race rotates counterclockwise.

##### 1-1

When the outer race starts rotating counterclockwise from a standstill at  $N_0$  r/min, the Cam Clutch engages and the inner race rotates in the same direction at  $N_0$  r/min.

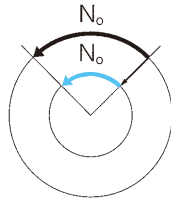

##### 1-2

When the inner race is rotated counterclockwise at  $N_1$  r/min by an outside force in the above state, and if  $N_1$  is faster than  $N_0$  ( $N_1 > N_0$ ), the Cam Clutch overruns and the inner race rotates at  $N_1$  r/min, and the outer race at  $N_0$  r/min.

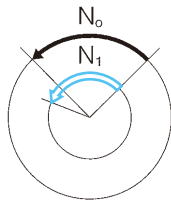

##### 1-3

When  $N_1$  and  $N_0$  become equal, either by deceleration of  $N_1$  or by acceleration of  $N_0$ , the Cam Clutch engages again, and this continues as long as  $N_0$  is faster than  $N_1$  ( $N_1 < N_0$ ), and transmits torque from the outer race to the inner race.

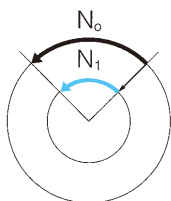

#### 2. Outer race rotates clockwise

##### 2-1

When the outer race starts rotating clockwise from a standstill at  $N_0$  r/min, the Cam Clutch overruns and the inner race remains at a standstill.

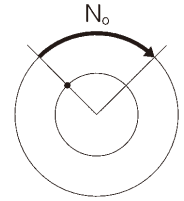

##### 2-2

When the inner race is rotated clockwise at  $N_1$  r/min by an outside force in the above state, and if  $N_0$  is faster than  $N_1$  ( $N_1 < N_0$ ), the Cam Clutch overruns and the inner race rotates at  $N_1$  r/min and the outer race at  $N_0$  r/min.

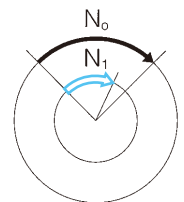

##### 2-3

When  $N_1$  and  $N_0$  become equal, either by acceleration of  $N_1$  or by deceleration of  $N_0$ , the Cam Clutch engages, stays engaged, and transmits torque from the inner race to the outer race as long as  $N_1$  is faster than  $N_0$ .

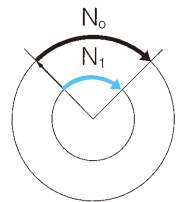

##### 2-4

If the inner race is rotated counterclockwise by another force, the Cam Clutch continues overrunning irrespective of the speed of rotation.

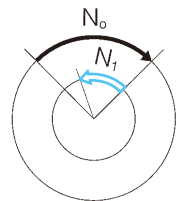

Application		Specification
Dual Drive Two Speed Drive	High-speed overrunning and high-speed engagement	Overrunning speed = 700 r/min and up, engaging speed = 700 r/min and up
	High-speed overrunning and medium and low-speed engagement	Overrunning speed = 700 r/min and up, engaging speed = Up to 700 r/min
	High-speed overrunning and low-speed engagement	Overrunning speed = 700 r/min and up, engaging speed = Up to 200 r/min
	Medium and low-speed overrunning and medium and low-speed engagement	Overrunning speed = Up to 700 r/min, engaging speed = Up to 700 r/min
Normal engagement and reverse overrunning		Input force is put into normal rotation for engagement and reverse rotation for overrunning.
Free wheeling		Overrunning starts when the rotating speed of the driven side becomes faster than the driving side.
Manual type		Continuous overrunning, manual engagement

## A-1. DUAL DRIVE AND TWO-SPEED DRIVE

Dual drive is a drive system in which two sets of driving units are installed instead of one driven unit, and the driven unit is driven by one or both of them as required. With dual drive, a drive system which has two sets of driving units having different speeds of rotation is referred to as “two-speed drive”, and the driven unit is driven at either high or low speed. Normally, each driving unit uses one Cam Clutch which works as an automatic switcher for the driving units. In the figure on the right, when the driven unit is to be driven by driving unit A in the direction of the arrow, Cam Clutch A engages to transmit the rotating power of the outer race to the inner race i.e., to the driven unit, and drives it at a preset speed of rotation. At this point, since the inner race of Cam Clutch B which is connected to the driven unit also rotates in the direction of the arrow, Cam Clutch B does not engage but overruns, thus disconnecting the driving unit B from the driven unit. Conversely, when the driven unit is to be driven by driving unit B in the direction of the arrow, Cam Clutch B engages to transmit the rotating power of the outer race to the inner race, i.e., to the driven unit, and drives it at a preset speed of rotation. At this time, Cam Clutch A overruns to disconnect driving unit A. Cam Clutch applications are divided into four types (as indicated in the table on the right) depending on the overrunning speed and the engaging speed.

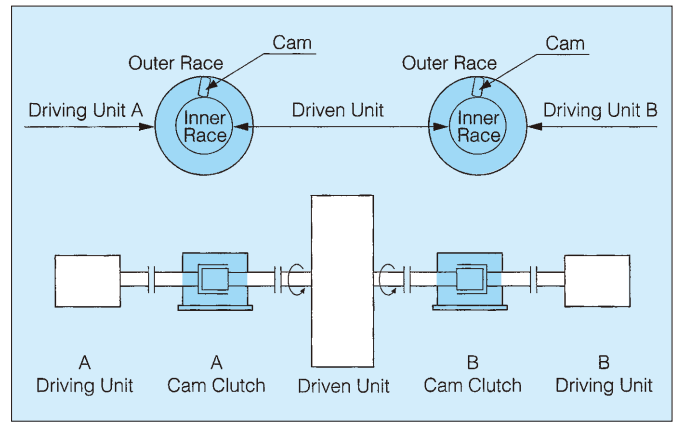

Application Page	Overrunning speed	Engaging speed	Applicable series	Page
High-speed overrunning and high-speed engagement.	700 r/min and up	700 r/min and up	Cam Clutch Box, MZ,MZEU	71 to 75, 22 to 30
High-speed overrunning and medium and low-speed engagement.	700 r/min and up	Up to 700 r/min	Cam Clutch Box, MZ,MZEU	71 to 75, 22 to 30
High-speed overrunning and low-speed engagement.	700 r/min and up	Up to 200 r/min	Cam Clutch Box, MZ,MZEU,MR, BR-HT, BR-P, BREU, TB	71 to 75, 22 to 30, 54 to 66, 76
Medium and low-speed overrunning and medium and low-speed engagement.	Up to 700 r/min	Up to 700 r/min	MZ, MG, 200, MZEU, PB, LD	22 to 31, 36,67

### A-1-1. High-Speed Overrunning and High-Speed Engagement (Overrunning speed = 700 r/min and up) (Engaging speed = 700 r/min and up)

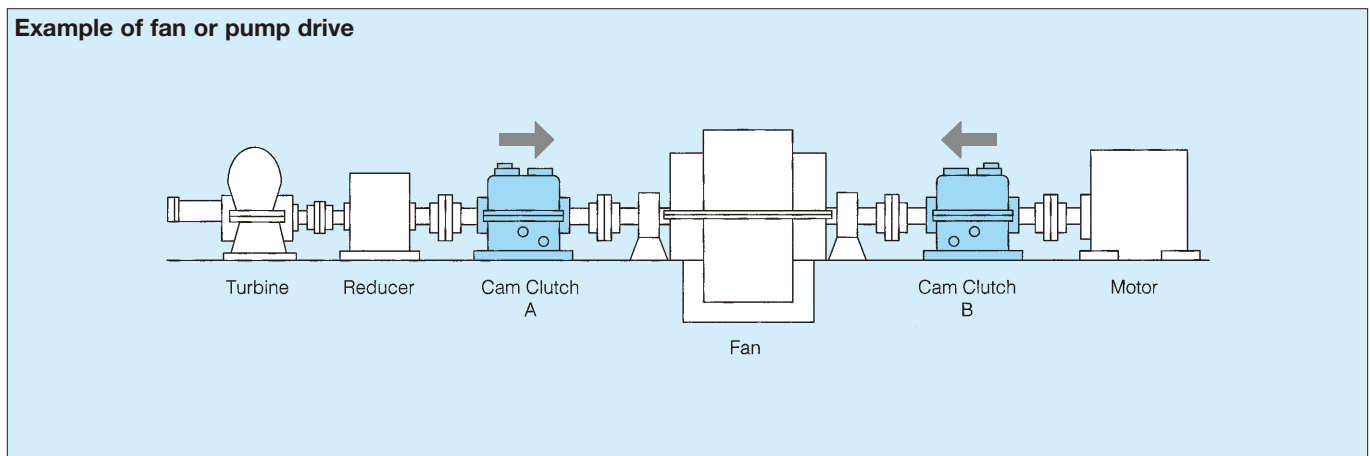

This example shows a high-speed system in which a driven unit (pump or fan) is driven by a dual drive system consisting of a motor and a turbine. The Cam Clutches are used for automatic switching between the driving units. The fan is normally driven by the Cam Clutch on the turbine side. When starting, or when steam pressure to the turbine drops, the motor takes over from the turbine to drive the fan. Cam Clutch A engages when the turbine drives the fan, and it overruns when the motor drives the fan. Conversely, Cam Clutch B overruns when the turbine drives the

fan, and it engages when the motor drives the fan. The driving devices can be changed over without switching the clutch. This is because the difference in the speed of rotation between the motor and turbine turns the Cam Clutches on and off, and the driving device rotating the fastest is connected automatically to the driven unit. Overrunning and engagement of the Cam Clutches are performed continuously at speeds faster than 700 r/min.

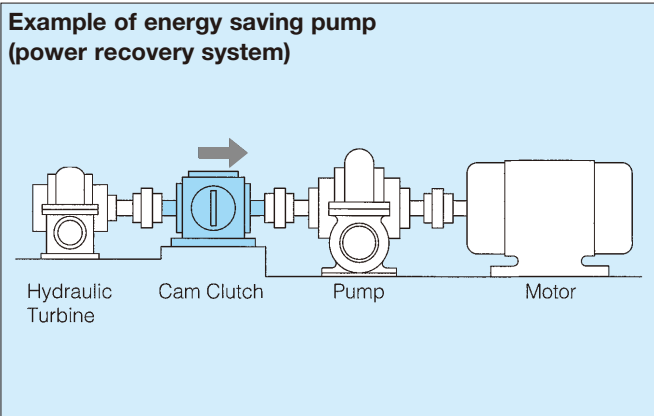

Application of Cam Clutches in an energy saving pump (power recovery system) shows how highly effective energy saving can be achieved with the aid of Cam Clutches. The motor-driven pump discharges high-pressure liquid, which, after circulating, is used to drive a turbine. The turbine is then used to help drive the pump. If the pressure available is too low to rotate the turbine at high speed, the Cam Clutch overruns. However, when the rotating speed of the turbine reaches the rotating speed of the motor, the Cam Clutch engages automatically and the pump is driven by both the turbine, and the motor. Thus, power consumption equivalent to the turbine output can be saved. Since energy loss during overrunning and engagement of the Cam Clutch is extremely small, this system produces results for pumps with an output as low as 7.5 kW. Setup requires only installation of a Cam Clutch and a turbine, and provides a high-efficiency energy recovery system with low running costs.

**Applicable Series**

Series	Advantage	Note	Page
Cam Clutch Box OB-ON OB-SN OB-SF OB-S	<ul style="list-style-type: none"> <li>• Can withstand extended continuous running.</li> <li>• Various lubricating and cooling systems can be used.</li> <li>• Minimal lubrication maintenance required.</li> </ul>	Please specify on the approval drawing that TSUBAKI issues when you place an order.	71 to 75
MZ,MZEU	<ul style="list-style-type: none"> <li>• Grease is sealed in.</li> </ul>	—	22 to 30

**A-1-2. High-Speed Overrunning and Medium and Low-Speed Engagement (Overrunning speed = 700 r/min and up) (Engaging speed = up to 700 r/min)**

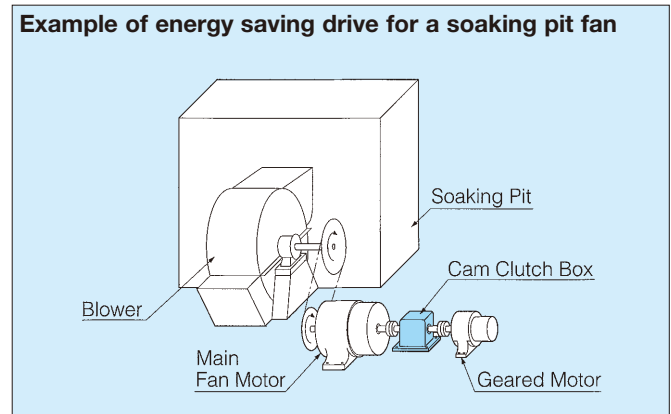

The Cam Clutch works as a switcher for two driving units (high-speed or medium/low-speed). When driving a fan, cement kiln or conveyor in normal operation, the driving speed is switched to high speed. When using them for other purposes, the driving speed is switched to medium or low-speed. The figure above shows a soak pit fan used for melting aluminum and steel ingots, with a Cam Clutch being used for energy saving. The heating is done in two stages, one being quick heating and the other being constant heating. Switching is done automatically by a driving system. For quick heating, the fan is driven by the main motor at high speed (the Cam Clutch is overrunning at this time). For constant heating, since the fan only rotates at low speed, it is driven by a geared motor (the Cam Clutch engages and the main motor and fan rotate simultaneously). Compared to pole change or inverter systems, great equipment cost savings can be made, and the initial equipment costs can be recovered very quickly. If equipment costs must be recovered within one year of continuous running, this system is effective for fans from the 15 kW class and up.

**Applicable Series**

Series	Advantage	Note	Page
Cam Clutch Box OB-ON OB-PN	<ul style="list-style-type: none"> <li>• Can withstand extended continuous running.</li> <li>• Minimal lubrication maintenance required.</li> </ul>	Please specify on the approval drawing that TSUBAKI issues when you place an order.	71 to 75
MZ,MZEU	<ul style="list-style-type: none"> <li>• Grease is sealed in.</li> </ul>	—	22 to 30
MR	<ul style="list-style-type: none"> <li>• The cam is the outer race overrunning type that lifts off.</li> </ul>	—	68

**A-1-3. High-Speed Overrunning and Low-Speed Engagement**  
**(Overrunning speed = 700 r/min and up)**  
**(Engaging speed = up to 200 r/min)**

**Applicable Series**

Series	Advantage	Note	Page
Cam Clutch Box OB-ON OB-PN TB	<ul style="list-style-type: none"> <li>• Can withstand extended continuous running.</li> <li>• Easy installation and space saving are possible with the TB series that are combined with speed reducers.</li> <li>• Minimal lubrication maintenance required.</li> </ul>	Please specify on the approval drawing that TSUBAKI issues when you place an order.	71 to 76
BR-HT, BR-P, BREU	<ul style="list-style-type: none"> <li>• The cam is the inner race overrunning type that lifts off.</li> </ul>	—	54 to 66
MZ, MZEU	<ul style="list-style-type: none"> <li>• Grease is sealed in.</li> </ul>	—	22 to 30
MR	<ul style="list-style-type: none"> <li>• The cam is the outer race overrunning type that lifts off.</li> </ul>	—	68

**Fan Drive Systems**

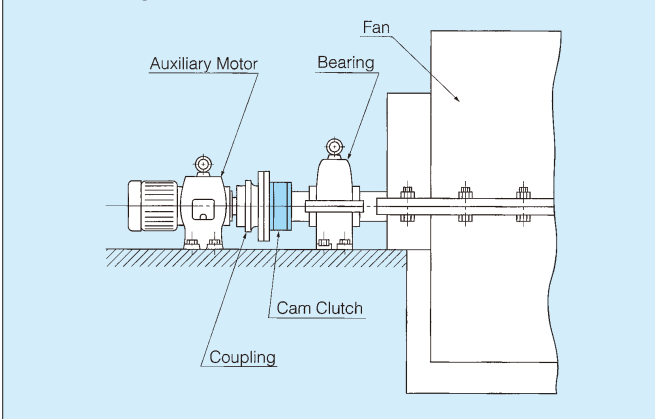

Smoke ventilation and gas mixing fans operate in high temperature environments. In order to prevent excessive thermal transfer from distorting the fan shaft, an auxiliary drive system is used to keep the fans rotating slowly when the main motor shuts down. Using a Cam Clutch at the auxiliary motor eliminates the need for manual clutch operation. Thermal expansion in the fan shaft must be absorbed through an expandable coupling. During main motor operation, the Cam Clutch rotates as a normal bearing, so service life is greatly extended.

**Turbine Auxiliary Drive Systems**

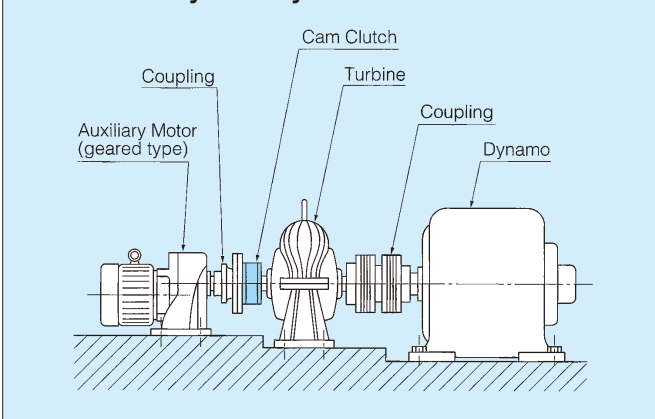

This example shows a Cam Clutch installed in the auxiliary drive system of a steam turbine. The auxiliary drive system powers the turbine at low speed through the engaged Cam Clutch, until steam pressure accelerates the turbine to the Cam Clutch release speed. Then the cam automatically disengages and runs as a high speed ball bearing, because there is no mechanical contact in the clutch.

### A-1-3. Medium and Low-Speed Overrunning and Medium and Low-Speed Engagement (Overrunning speed = Up to 700 r/min) (Engaging speed = Up to 700 r/min)

In this application, one driven unit is driven at two speeds by two medium and low-speed drive units, both at speeds lower than 700 r/min. Two Cam Clutches enable automatic switching between the drive units.

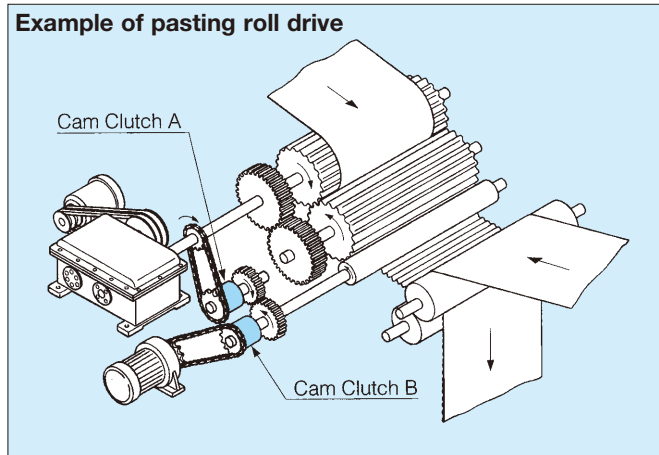

The above figure shows an example of Cam Clutches being used with the pasting rolls of a corrugating machine for making cardboard. The pasting rolls are driven continuously by the main motor. During this time, Cam Clutch A engages and Cam Clutch B overruns. When the main motor must be stopped temporarily to fix a problem, it is necessary to keep rotating the pasting rolls in order to prevent paste on the roll surface from drying. To do this, the rolls are driven by an auxiliary motor at a low speed sufficient to prevent the paste from drying (Cam Clutch A overruns, while B engages). This system is also used with meat choppers and screw feeds in food processing machinery.

#### Applicable Series

Series	Advantage	Page
MZ,MZEU	<ul style="list-style-type: none"> <li>Grease is sealed in.</li> </ul>	22 to 30
MG	<ul style="list-style-type: none"> <li>Compact and transmits high torque.</li> <li>Excellent wear resistance when overrunning.</li> </ul>	67
BB	<ul style="list-style-type: none"> <li>Same dimensions as the #62 type bearing.</li> <li>Integrated Cam Clutch and bearing.</li> </ul>	32,33
PB	<ul style="list-style-type: none"> <li>Sleeve-type outer race enables mounting of sprocket or gear with small outer diameter.</li> <li>Use of oil-impregnated alloy bearings makes oiling to the bearing section unnecessary.</li> </ul>	36
200	<ul style="list-style-type: none"> <li>Since this series is mounted directly on the shaft, it is possible to use a shaft of large diameter.</li> <li>Compact designs are possible.</li> </ul>	31
LD	<ul style="list-style-type: none"> <li>Grease is sealed in, so lubrication maintenance is not required.</li> <li>For light loads and low-speed drive.</li> </ul>	37
TSS	<ul style="list-style-type: none"> <li>Outside dimensions are the same as #62 type bearing.</li> <li>Compact designs are possible.</li> </ul>	34
TFS	<ul style="list-style-type: none"> <li>Outside dimensions are the same as #63 type bearing.</li> </ul>	35

### A-2. NORMAL ENGAGEMENT REVERSE OVERRUNNING

In this application, the normal rotating input power is held for a certain time and, after driving the driven side through the engagement of the Cam Clutch, the Cam Clutch is put into the overrunning state by reversing the input power. This application is classified into the following three kinds, depending upon the purpose for overrunning the Cam Clutch:

1. To simply break the linkage between the input side and the driven unit (for details, see A-2-1 below).
2. To make the driven unit rotate in reverse by drive from another source after making the input side rotate in reverse, and brake the load by engagement of the clutch when the speed of rotation of the driven unit has reached that of the input side (for details, see A-2-2 below).
3. To selectively drive either one of the driven units A or B connected respectively to the outer races of the different aligned Cam Clutches A and B, which are connected to the same drive shaft. When Cam Clutch A engages due to normal rotation of the shaft, Cam Clutch B overruns, and when Cam Clutch B engages due to reverse rotation of the shaft, Cam Clutch A overruns (for details, see A-2-3 below).

#### A-2-1. Application requires breaking connection only (see the figure below)

This example shows the use of a Cam Clutch with an inclined pump. If the motor is wired in reverse by mistake at installation, it will rotate the pump in reverse. By mounting a Cam Clutch between the motor and the pump, reverse rotation of the pump (which must not be allowed) is prevented because the Cam Clutch will overrun if the motor rotates in reverse. The Cam Clutch stays engaged at all times when the rotation is normal.

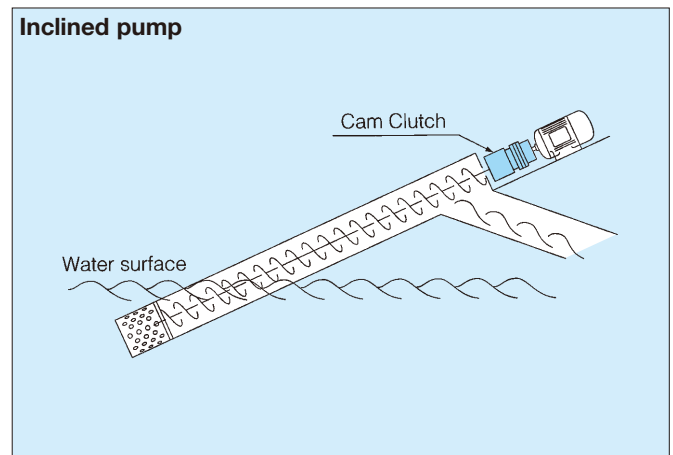

### A-2-2. Application for the purpose of braking the driven side (see the figure below)

The example here shows an application in which the hose drum of a pipe flusher is being driven. When the hydraulic motor is rotated in reverse in the counterclockwise direction, the Cam Clutch inner race rotates in reverse, and the Cam Clutch overruns. The flushing pump is driven in this state. The flushing water passes through the hose and gushes out of the nozzle toward the back. The force of this water jet starts the nozzle running and pulls and unwinds the hose. At the same time, the hose drum starts reverse rotation in the same counterclockwise direction, and increases its speed of rotation until it reaches the overrunning speed of the inner race. At this point, the Cam Clutch engages, and the hydraulic motor works as a brake to stop the acceleration of the drum. Therefore, the running speed of the water jet nozzle is kept constant thereafter. When the hydraulic motor is rotated normally in the clockwise direction, the Cam Clutch engages to wind the unwound hose onto the drum.

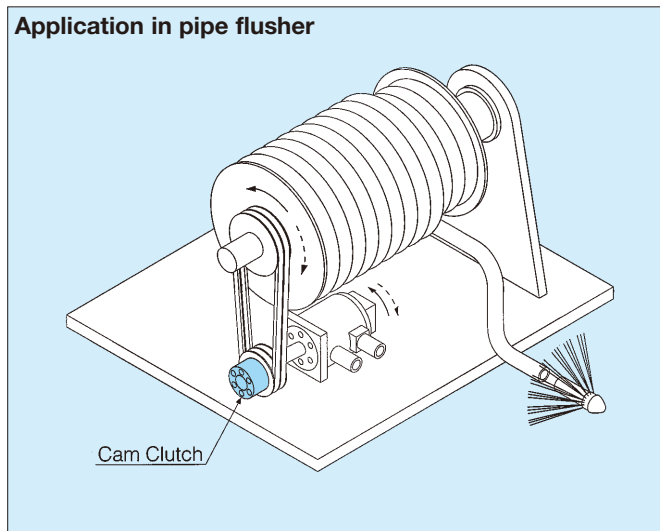

### A-2-3. Application for the purpose of selectively driving either one of two driven units by normal or reverse rotation of the drive input (see the figure below)

When the motor is rotating normally (in the counterclockwise direction), Cam Clutch A engages to drive unit A, and Cam Clutch B overruns. Conversely, when the motor is rotated in reverse (in the clockwise direction), Cam Clutch B engages to drive driven unit B. In this application, the two driven units must work independently.

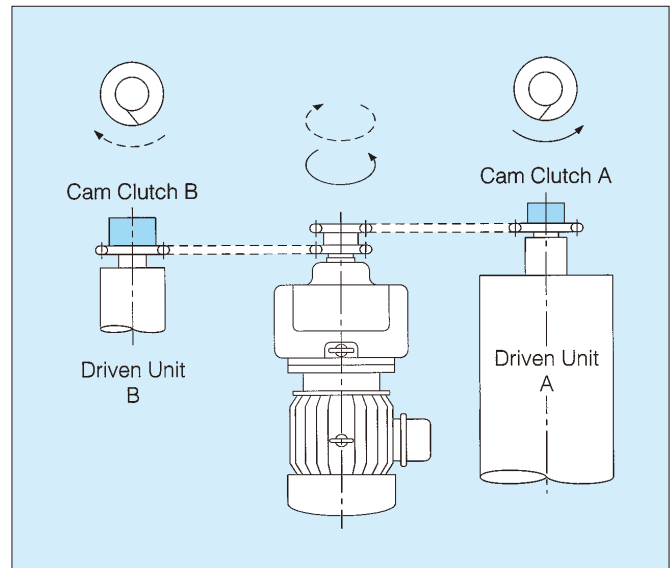

### Applicable Series

Series	Advantage	Caution	Page
MZ,MZEU	<ul style="list-style-type: none"> <li>Grease is sealed in.</li> </ul>	When the engaged time is long and load change is considerable, choose the SS (reinforced spring) specification. In this specification, the response of cam following load changes during Cam Clutch engagement is enhanced. Use the Cam Clutch at an overrunning speed of 50 r/min or lower.	22 to 30
BB	<ul style="list-style-type: none"> <li>Same dimensions as the #62 type bearing.</li> <li>Integrated Cam Clutch and bearing.</li> </ul>		32,33
PB	<ul style="list-style-type: none"> <li>Sleeve-type outer race enables mounting of sprocket or gear with small outer diameter.</li> <li>Use of oil-impregnated alloy bearings makes oiling the bearing section unnecessary.</li> </ul>		36
200	<ul style="list-style-type: none"> <li>Since this series is mounted directly to the shaft, it is possible to use a large diameter shaft.</li> <li>Compact designs are possible.</li> </ul>		31
LD	<ul style="list-style-type: none"> <li>Grease is sealed in, so lubrication maintenance is not required.</li> <li>For light loads and low-speed drive.</li> </ul>		37
MG	<ul style="list-style-type: none"> <li>Compact and transmits high torque.</li> <li>Excellent wear resistance when overrunning.</li> </ul>		67
MI	<ul style="list-style-type: none"> <li>MG type reinforced spring type. Excellent response to load change.</li> </ul>		67
TSS	<ul style="list-style-type: none"> <li>Outside dimensions are the same as #62 type bearing.</li> <li>Compact designs are possible.</li> </ul>		34
TFS	<ul style="list-style-type: none"> <li>Outside dimensions are the same as #63 type bearing.</li> </ul>		35

### A-3. FREE WHEELING

To prevent differences in the rotating speed between the driving side and the driven side from damaging the driving unit or the product, the Cam Clutch overruns when speed differences occur. Normally, the Cam Clutch engages to transmit torque, and it overruns to break the connection between the driving side and the driven side. In this case the Cam Clutch overruns at a speed equal to the difference in rotating speed that occurs when the driven unit (normally the inner race) rotates faster than the driving unit (normally the outer race), or when the driving unit is decelerated or stopped abruptly. When feeding hoop-shaped material or plate material to the next process by slitter or pressure rolls, the material is fed at first by pinch rolls up to the main rolls. Since the main rolls process the material while pulling it at a speed faster than that of the pinch rolls, the pinch rolls are pulled by the material. At this point, the Cam Clutch starts to overrun and prevents the pinch rolls from being driven in reverse by the material. The Cam Clutch is used to prevent damage to the pinch roll driving parts and to the material, due to slippage between the pinch rolls. This method is also used with drying machines, engine testers, and plywood fabricating machines.

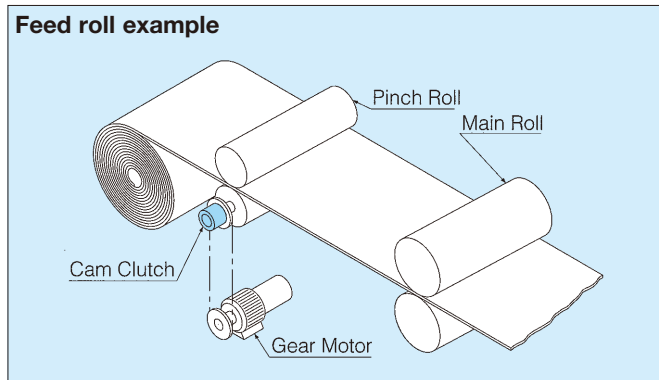

#### Applicable Series

Series	Advantage	Page
MZ,MZEU	• Grease is sealed in.	22 to 30
MG	• Compact and transmits high torque.	67
BB	• Same dimensions as #62 type bearing. • Integrated Cam Clutch and bearing.	32,33
PB	• Sleeve-type outer race enables mounting of sprocket or gear with small outer diameter.	36
200	• Since this series is mounted directly on the shaft, it is possible to use a shaft of large diameter.	31
LD	• Grease is sealed in, so lubrication maintenance is not required. • For light loads and low-speed drive.	37
MI	• Excellent response to load change.	67
TSS	• Outside dimensions are the same as #62 type bearing. • Compact designs are possible.	34
TFS	• Outside dimensions are the same as #63 type bearing.	35

#### SS Specification (reinforced spring specification)

In this specification, the response of cam following load changes during Cam Clutch engagement is enhanced. Use the Cam Clutch at an overrunning speed of 50 r/min or lower.

### A-4. MANUAL TYPE

Cam Clutches are used when a machine is operated manually for positioning, adjustment or inching. The Cam Clutch mounted at the manual handle overruns while the machine is in operation. The handle does not rotate and cause a safety hazard.

Cam Clutches are used in the manual handles of circular knitting machines. The manual handle is used to operate the machine manually when starting, for adjustment of the needle and thread. When the machine starts its regular knitting work after the adjustment, the linkage between the Cam Clutch and the handle is broken. Another Cam Clutch is provided at the output section of the worm reduction gears, to break the connection with driving side during manual operation. Since this Cam Clutch engages to drive the circular knitting machine during regular operation, the large torque capacity PB12 is used.

#### Manual operation example

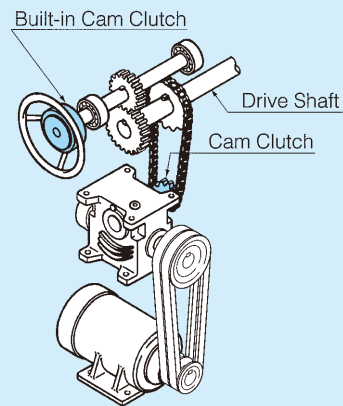

#### Applicable Series

Series	Advantage	Page
LD	• For low-speed overrunning. • No maintenance.	37
MZ,MZEU	• For medium-speed overrunning.	22 to 30
200	• For medium-speed overrunning. • Since this series is mounted directly on the shaft, it is possible to use a shaft of large diameter.	31
BB	• Same dimensions as #62 type bearing. • Integrated Cam Clutch and bearing.	32,33
PB	• For medium-speed overrunning. • Since it has a sleeve type outer race, it can be mounted easily on a handle with a small boss diameter.	36
TSS	• Outside dimensions are the same as #62 type bearing. • Compact designs are possible.	34
TFS	• Outside dimensions are the same as #63 type bearing.	35

For normal and reverse driving in the above examples, specially designed Cam Clutches are available. Please contact TSUBAKI for details.

## B. INDEXING (INTERMITTENT FEED)

### Cam Behavior and Cam Clutch Operation

In this application, reciprocal movement of a certain angle ( $\theta$ ) is provided at the outer race of the Cam Clutch to perform engagement and overrunning in turn continuously and obtain intermittent rotation. In the case of the Cam Clutch shown in the figure, when the outer race moves from A to B, the Cam Clutch engages to rotate the inner race (of the driven side) by angle  $\theta$ , i.e., from a to b. However, the Cam Clutch does not operate to stop the inner race at position b. When the outer race rotates in reverse from B to A, the Cam Clutch overruns while the inner race (of the driven side) does not rotate. By repeating this sequential movement, the inner race (of the driven side) rotates intermittently within the preset angle ( $\theta$ ).

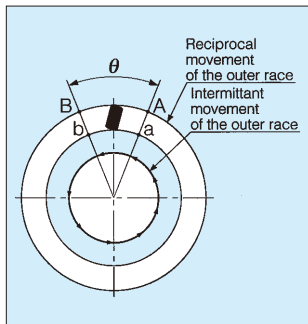

### Advantages of indexing mechanisms that use Cam Clutches

1. Accurate feeding without backlash.
2. Feeding distance can be simply adjusted and is stepless.
3. The indexing mechanism has low running costs.

### Classification into six applications

	Application	Specification	Page
Indexing	(1) High speed and small feed angle	Frequency (number of rotations) = 300/min. and above Feed angle ( $\theta$ ): Up to 90°	15
	(2) Medium and low speed and small feed angle	Frequency (number of rotations) = 300/min. or less Feed angle ( $\theta$ ): Up to 90°	16
	(3) Low-speed and large feed angle	Frequency (number of rotations) = 150/min. or less Feed angle ( $\theta$ ): 90° and up	16
	(4) Backstopping in intermittent feeding	Frequency and feed angle are the same as those of Cam Clutches for feeding.	17
	(5) Feeding with stopper	Application method is the same as (2) except that material is stopped by force during feeding.	17
	(6) Speed change	Application method is the same as (2) except that the rotating speed is changed by steplessly changing the feed angle ( $\theta$ ) during operation.	18

## B-1. HIGH SPEED AND SMALL FEED ANGLE

(Feed frequency:  $N = 300$  to  $1200$  times/min.)

(Feed angle:  $\theta =$  Up to 90°;  $N \times \theta = 20000$  max.)

The example in the figure shows a roll feeding device which is frequently used in high-speed automatic clamp presses. Driving power is taken out of the eccentric disk provided at the end of the continuously rotating crankshaft, and this power drives the feed rolls intermittently through a Cam Clutch. The feed length can be changed quickly and easily for improved work efficiency. In order to attain high-speed, high-precision feeding, a cone brake with less torque fluctuation and a Cam Clutch for backstopping are used together.

The Cam Clutches in this application are designed for use in the range of  $(N \times \theta) \leq 20000$ . Please consult TSUBAKI regarding clutches for use outside of this range.

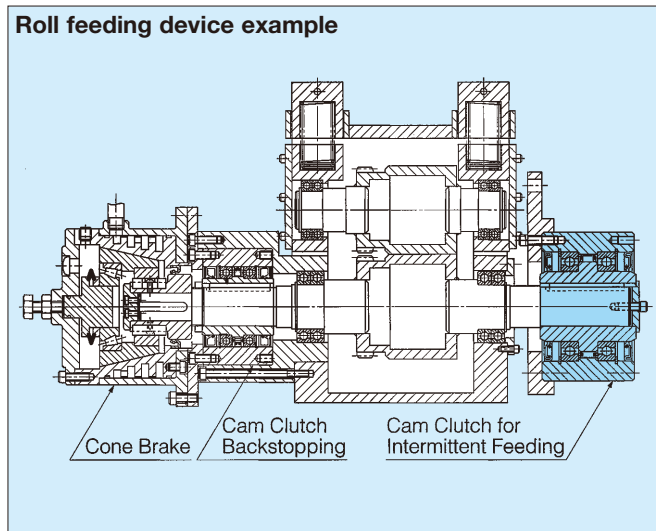

### Feed accuracy

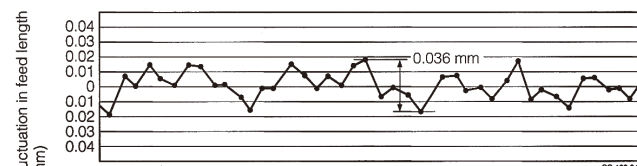

The figure shows values which have been converted from the data of a rotary encoder on a 100 mm diameter roll.

### [Specifications]

- Clutch model : MX35
- Feed frequency : 900 times/min.
- Feed length : 26.6 mm
- Load Inertia : 0.01 kg·m<sup>2</sup>
- Braking torque : 39.2 N·m

### Applicable Series

Series	Advantage	Page
MX	<ul style="list-style-type: none"> <li>• Suitable for high-speed indexing with a small feed length.</li> <li>• High feeding accuracy is possible.</li> </ul>	39

## B-2. MEDIUM AND LOW SPEED AND SMALL FEED ANGLE

(Feed frequency :  $N = \text{Up to } 300 \text{ times/min.}$ )  
 (Feed angle:  $\theta = \text{Up to } 90^\circ$ ;  $N \times \theta = 20000 \text{ max.}$ )

Indexing in this application range is applicable to many machines. The figure shows an example of use in the paper feeding section of an automatic stapler. The reciprocating movement of the eccentric disk is converted by the Cam Clutch into an intermittent feed motion, which drives the belt conveyor. Hence, stapling is timed to the intermittent feeding motion and load overrun is prevented by a brake. Stapling is done at an exact pitch. This indexing can be applied extensively to food and other packaging machines.

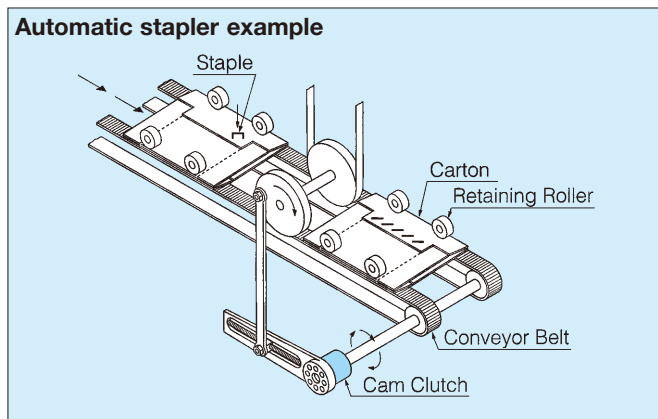

### Applicable Series

Series	Advantage	Page
MI	<ul style="list-style-type: none"> <li>For medium speeds (up to 300 times/min.).</li> <li>Since a free-action type cam retainer is used, the cam has excellent follow-up response at the time of engagement.</li> </ul>	67
MZ,MZEU	<ul style="list-style-type: none"> <li>For low speed (up to 150 times/min.).</li> </ul>	22 to 30
200	<ul style="list-style-type: none"> <li>For low speed (up to 150 times/min.).</li> <li>Since this series is mounted directly on the shaft, it is possible to use a shaft of large diameter.</li> </ul>	31
BB	<ul style="list-style-type: none"> <li>For low speeds (up to 100 times/min.).</li> <li>Same dimensions as #62 bearing.</li> </ul>	32,33
PB	<ul style="list-style-type: none"> <li>For low speeds (up to 150 times/min.).</li> <li>Sleeve-type outer race enables mounting of sprocket or gears as well as torque arms with small boss diameter.</li> </ul>	36
LD	<ul style="list-style-type: none"> <li>For low speeds (up to 100 times/min.).</li> <li>For light loads, no maintenance.</li> </ul>	37
MI-S	<ul style="list-style-type: none"> <li>For medium speeds (up to 300 times/min.).</li> <li>Use of a cam finished by special surface hardening improves abrasion resistance.</li> </ul>	40
MX	<ul style="list-style-type: none"> <li>For high speeds (up to 1200 times/min.).</li> <li>Applicable also to low speeds.</li> </ul>	39

## B-3. LOW SPEED AND LARGE FEED ANGLE

(Feed frequency :  $N = \text{Up to } 150 \text{ times/min.}$ )  
 (Feed angle:  $\theta = 90^\circ \text{ and up; } N \times \theta = 50000 \text{ max.}$ )

Segmented gears and rack & pinions are often used to produce the reciprocal movement to be transmitted to the Cam Clutch. The figure below gives an application example of a pouch making machine. Since the reciprocal movement of the eccentric disk is accelerated through the rack & pinion assembly, the reciprocal action of the Cam Clutch outer race is enlarged to  $860^\circ$ . In this machine, the 60 mm vinyl sheet feeding length is indexed at a speed of 40 to 60 times per minute. In this case, the acceleration of the Cam Clutch increases, a large torque acts repeatedly, and the cam slipping distance at overrunning becomes longer. Hence, a cam is required that has superior engagement and higher anti-abrasive properties. A brake is used in order to improve the precision of the vinyl sheet feeding pitch.

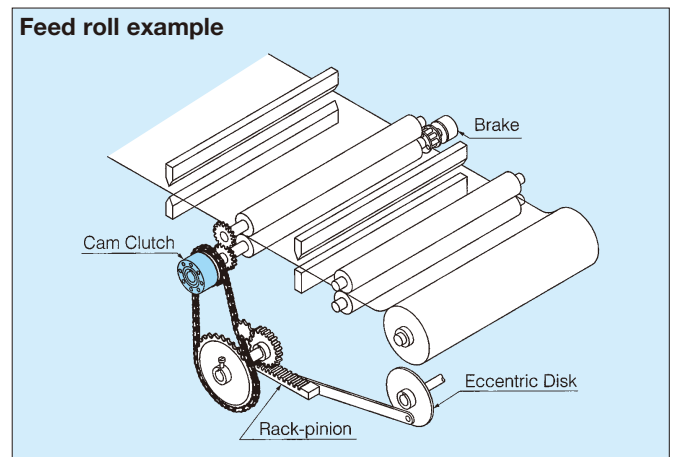

### Applicable Series

Series	Advantage	Page
MI-S	<ul style="list-style-type: none"> <li>The MI-S Series has been developed exclusively for these applications.</li> <li>Special cam surface hardening treatment improves the abrasion resistance.</li> <li>The shape and structure of the cam are specially designed so that it can handle abrupt speed changes (e.g. great acceleration) when engaging.</li> </ul>	40

## B-4. BACKSTOPPING IN INTERMITTENT FEEDING

### Cam clutch and feed accuracy

When designing a high-accuracy feeding device that incorporates Cam Clutch indexing, both the driving and driven units must be made light in weight and high in rigidity. Moreover, when selecting the ideal Cam Clutch, it is extremely important to select a brake to stop the driven unit at a preset position, a positioning device, and a Cam Clutch for backstopping (which cannot be expected of the Cam Clutch for indexing).

**Feed accuracy = Cam Clutch for indexing +  
Cam Clutch for backstop + Brake**

### Cam Clutch for backstopping

This Cam Clutch overruns when the Cam Clutch for indexing has completed one feeding stroke. If the frictional resistance of the driven unit is smaller than the overrunning frictional torque of the Cam Clutch, or if a reverse torque occurs on the driving side due to back tension of the material, the driven unit may rotate in reverse without stopping at the end point fed by the Cam Clutch. The most effective way to prevent this is to mount a Cam Clutch for backstopping, although a brake or positioning pin may also be used for this purpose. Since the Cam Clutch for backstopping repeats the overrunning and engagement at the same frequency as that of the Cam Clutch for indexing, use one that is equivalent to the feeding clutch or one that is one size smaller.

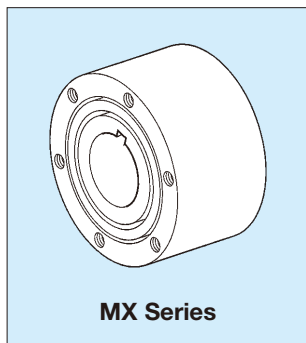

### Brakes and other stopping devices

The outer race of a Cam Clutch for indexing starts reverse rotation immediately upon the completion of one feeding stroke. At the same time, the Cam Clutch starts overrunning. At this moment, the driven unit is free from all restrictions, and therefore, when the driven unit has a larger inertia or the feed speed is faster, the inner race tends to rotate beyond the stroke of the outer race. To prevent this, a friction brake is often used as a braking device, although a positioning pin or stopper may also be used for this purpose. A braking device significantly improves the feed accuracy. Accordingly, use a frictional brake which has as small a fluctuation as possible in its braking force. The wet-type cone brake is most effective. Please consult TSUBAKI regarding brake selection.

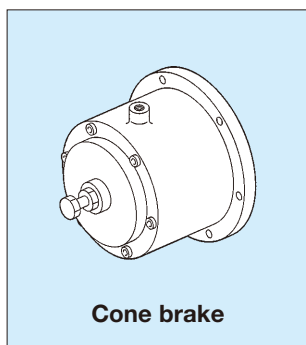

## B-5. FEEDING WITH STOPPER

(Feed frequency = Up to 300 times/min.)

(Feed angle = up to 90°)

In this application, a stopper forcibly stops the material to be indexed at a position just before the feed end point, to obtain a fixed feeding pitch. As soon as the material hits the stopper, a shock torque larger than the torque required for feeding is applied to the feeding roll which is still rotating. The figure below shows an example of a Cam Clutch used in a bolt header. The wire is fed intermittently by a Cam Clutch mounted on a grooved feed roll. Since the feed length of the wire is set longer than necessary, the fed wire hits the stopper which has been set at a position where the wire can be fed at the necessary length. The reactive force this generates acts as vibrating shock load upon the Cam Clutch. It is therefore necessary to consider this when selecting a Cam Clutch.

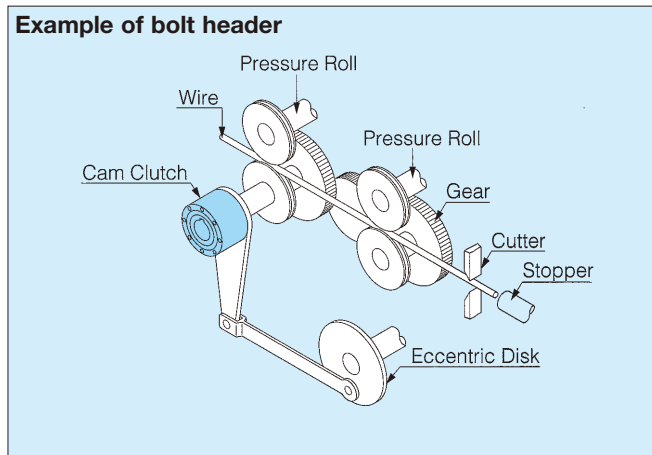

### Applicable Series

Consult TSUBAKI.

### Cautions

When setting the feed length, consider the following:

Feed length setting = Necessary length +  $\alpha$

The closer to zero  $\alpha$  is, the smaller the vibrating shock load on the Cam Clutch becomes and consequently, the longer the service life becomes.

## B-6. SPEED CHANGE

(Feed frequency :  $N = \text{Up to } 300 \text{ times/min.}$ )

(Feed angle :  $\theta = \text{Up to } 90^\circ$ ;  $N \times \theta = 20000 \text{ max.}$ )

In an intermittent feed mechanism that uses one or more Cam Clutches, the speed of the driven side is changed steplessly by changing the feed angle. The figure below shows an example of a sprinkler (manure spreader). The amount of manure to be sprinkled, which varies depending on the field conditions, must be adjusted case by case. The chain conveyor is driven by an intermittent Cam Clutch feeding action and the manure loaded on the cart is fed in bits to the sprinkling vanes, which rotate continuously. The manure to be sprinkled can thus be kept at the optimum amount by adjusting the amount of manure to be fed. The feed amount (or angle of the Cam Clutch) can be controlled steplessly while the sprinkler is operating.

Structure of speed controlling section

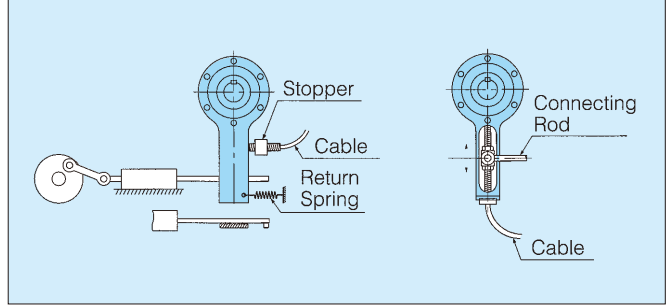

Applicable Series

Series	Advantage	Page
MI-S	For medium speeds (Up to 300 times/min.)	40
MI	For medium speeds (Up to 300 times/min.)	68
MZ,MZEU	For low speeds (Up to 150 times/min.)	22 to 30
200 PB	For low speeds (Up to 150 times/min.)	31 36
LD	For low speeds (Up to 100 times/min.) and light loads	37

Sprinkler example

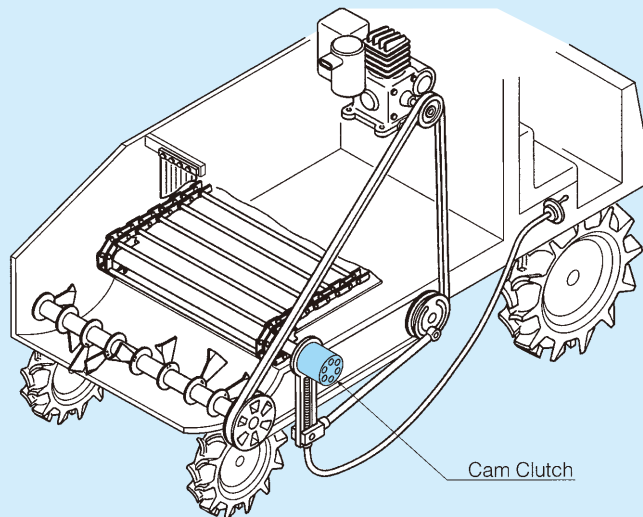

## C. BACKSTOPPING TO PREVENT REVERSE ROTATION

Backstopping is used to prevent the rotating shaft from rotating in the reverse direction. The Cam Clutch continues overrunning while the shaft rotates normally, and it engages to prevent reverse shaft rotation just before it is about to occur.

### Behavior and function of Cam Clutch

Normally, the inner race is mounted on the rotation shaft, and the outer race is fixed to the machine frame. The inner race is thus set on the overrunning side. As soon as the shaft begins to rotate in reverse, the cams engage with the inner and outer races to prevent reverse rotation and support the load.

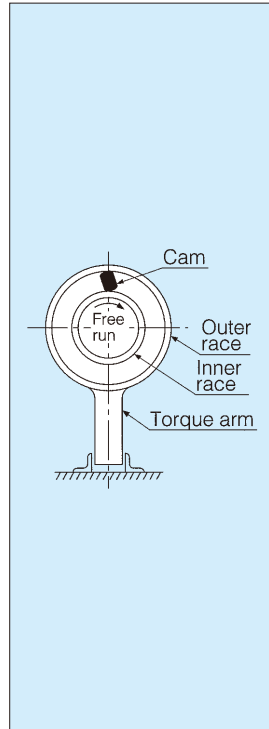

Prevention of reverse rotation of inclined and vertical conveyors is a typical example of how backstopping is used. The following A, B, and C types are available for different Cam Clutch mounting positions, and the series listed are designed to handle each specification.

Type of mounting	Mounting position	Use	Specification (overrunning speed/reversing torque)	Applicable series	Page
A	Pulley shaft	Backstopping for low-speed overrunning	0 to approx. 150 r/min; Large reversing torque.	BS BS-F BS-R BSEU	41 to 53
B	Intermediate shaft of reduction gears	Backstopping for medium-speed overrunning	Approx. 150 to 700 r/min; Medium reversing torque.	MG-R	69
C	Directly connected to motor shaft	Backstopping for high-speed overrunning	300 to 3,600 r/min; Small reversing torque.	BR-HT BR-P BREU	54 to 66

### Three classifications

Backstopping is classified into three types depending on the overrunning speed and load conditions.

Backstopping	Purpose of use		Overrunning speed	Engagement	Major applications	Page
	(1)	Backstopping for low-speed overrunning	Continuous overrunning at 150 r/min or less	Irregular, low-frequency engagement	For backstopping of conveyor shafts, pumps, etc.	20
	(2)	Backstopping for medium-speed overrunning	Continuous overrunning at 150 to 700 r/min		For backstopping of intermediate shafts of conveyor-drive reduction gears.	20
	(6)	Backstopping for high-speed overrunning	Continuous overrunning at 700 to 3600 r/min		For backstopping of high-speed rotating shafts in conveyor-drive machines, pumps, etc.	20

### A, B, and C mounting types

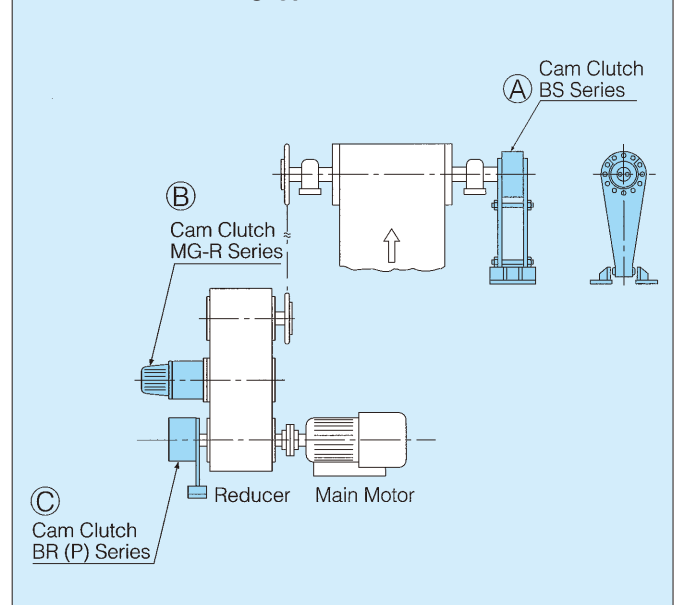

## C-1. BACKSTOPPING FOR LOW-SPEED OVERRUNNING

(Overrunning speed at 150 r/min or less)

In this application, the inner race of the Cam Clutch is mounted directly onto the conveyor head pulley, or other shaft with a low-speed of rotation, while the outer race is anchored to the conveyor frame to prevent reverse rotation.

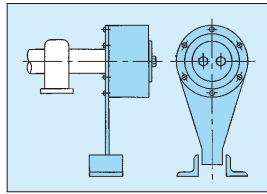

Since reverse rotation is prevented directly by the conveyor shaft without using a drive chain, gears, or couplings, this is regarded as the safest and most reliable mounting method. Additionally, a low overrunning speed minimizes the cam overrunning slip speed, as well as the overall slipping distance. As a result, wear on the cam is reduced and a prolonged service life can be expected. In addition to conveyors, this system is also used to prevent reverse rotation in inclined and screw pumps.

### Applicable Series

Series	Advantage	Page
BS BS-F BS-R BSEU	<ul style="list-style-type: none"> <li>• Cam Clutch designed for conveyor backstopping.</li> <li>• Designed to be perfectly dust-proof.</li> <li>• Lubrication is greatly enhanced by the cam-roller combination.</li> <li>• Grease is sealed in, so lubrication maintenance is almost never required.</li> </ul>	41 to 53

Depending on conditions, the following series can also be used for this purpose: MG (page 67), MG-R (page 69), MZ, MZEU (page 22 to 30), BB (page 32), PB (page 36), 200 (page 31) and LD (page 37) Series

## C-2. BACKSTOPPING FOR MEDIUM-SPEED OVERRUNNING

(Overrunning speed = 150 to 700 r/min)

In this application, the Cam Clutch is mounted on shafts rotating at medium speeds, such as the intermediate shafts of reduction gears, etc., to prevent reverse rotation. Since reverse rotation is prevented by the medium-speed shaft, the Cam Clutch required only needs to withstand a comparatively small torque which is inversely proportional to the rotating speed ratio of the conveyor shaft. Accordingly, even a small-sized Cam Clutch can be used for this purpose.

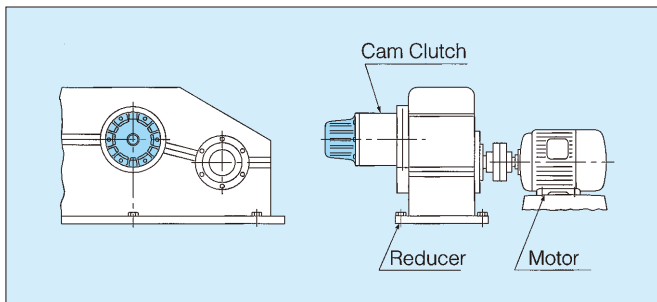

### Applicable Series

Series	Advantage	Page
MG-R	<ul style="list-style-type: none"> <li>• The oil reservoir provided with this series accommodates a large amount of oil to reduce maintenance.</li> <li>• Compact and able to transmit large torques.</li> <li>• Excellent wear resistance when overrunning.</li> </ul>	69
200	<ul style="list-style-type: none"> <li>• Since this series is mounted directly on the shaft, it is possible to use shafts of large diameters.</li> <li>• Ideal for use with reduction gears.</li> </ul>	31

The following series, which have sealed-in grease and are maintenance free, can also be used for this purpose: MZ, MZEU (page 22 to 30) and PB (page 36) Series.

## C-3. BACKSTOPPING FOR HIGH-SPEED OVERRUNNING

(Overrunning speed = 700 to 3600 r/min)

This example shows a Cam Clutch installed to the motor shaft of an inclined conveyor system, to prevent reverse rotation. Low torque Cam Clutches can also be installed to high speed shafts. Cam Clutches are excellent for space-limited applications because they can be used as is for replacements for standard ball bearing cassettes.

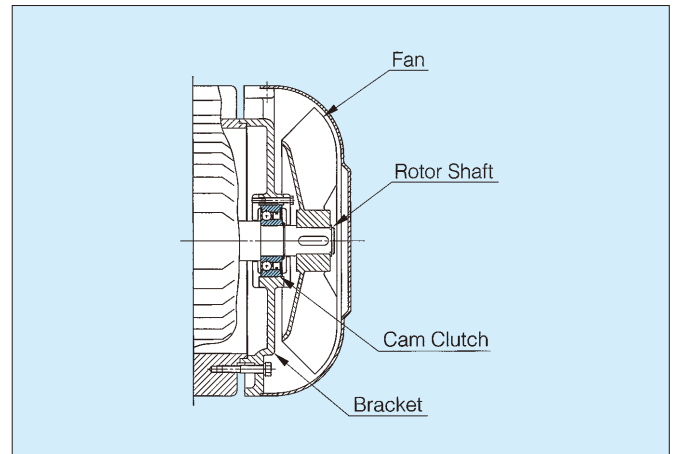

This example shows a Cam Clutch installed to a motor pulley to prevent reverse rotation. Cam Clutches can be installed to inclined belt conveyor systems to prevent reversing when the conveyor stops, as a result of power loss or other causes.

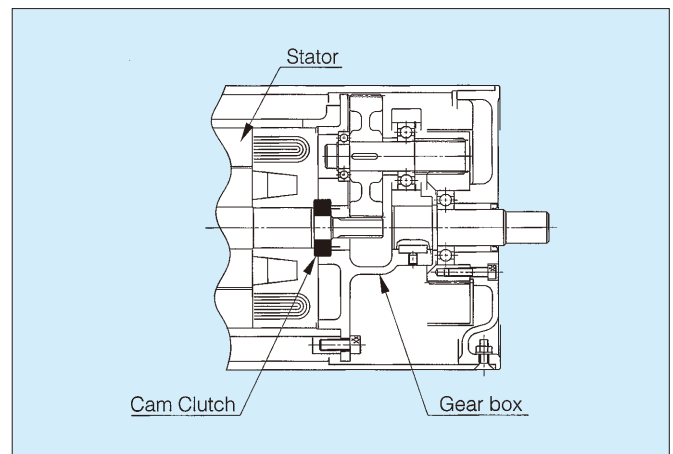

### Applicable Series

Series	Advantage	Page
BB	<ul style="list-style-type: none"> <li>• Same dimensions as #62 bearing unit.</li> <li>• One-piece construction of bearing and Cam Clutch.</li> </ul>	32,33

There are many cases in which large scale vertical motor or pump systems must be kept from turning backwards. A Cam Clutch can be installed above the motor of a vertical motor system, or on the mainshaft of a vertical pump, to provide this function. Anchoring the outer race of the Cam Clutch will prevent the inner race from rotating in the reverse direction.

Many liquid media transmission systems use multiple pumps or compressors feeding into the same line, to save energy or provide emergency backup functions. System pressure will often cause the pump or compressor to back-spin when not running. A Cam Clutch can prevent this.

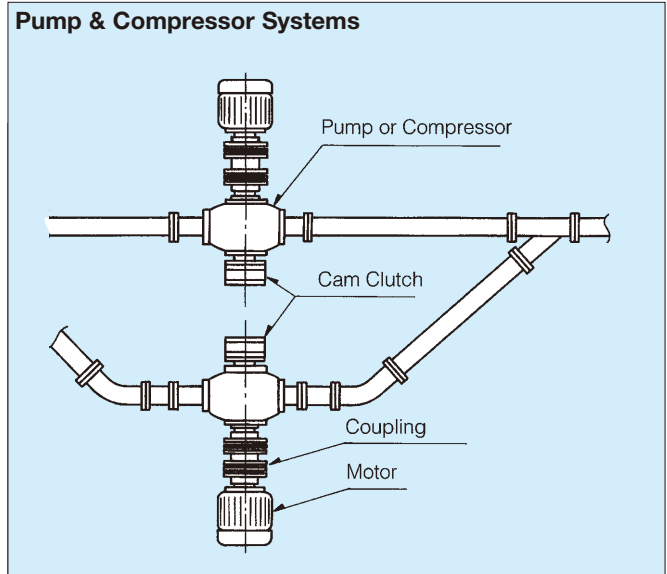
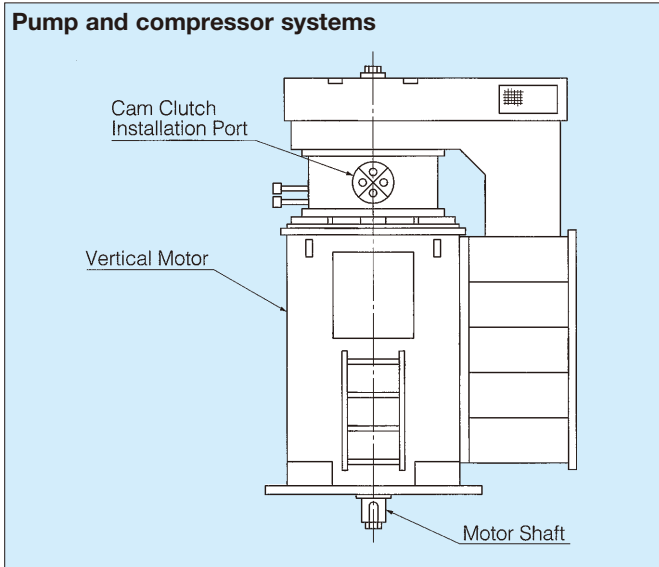

For reasons of safety, belt conveyors must be prevented from moving backwards. Installing a Cam Clutch on the main motor shaft is the easiest and most economical method for this. For certain large and mid-scale belt conveyors with high lift distances, it may be more economical to install the Cam Clutch on one of the high speed shafts. In these cases it is important to verify the torque load applied to the engaged clutch.

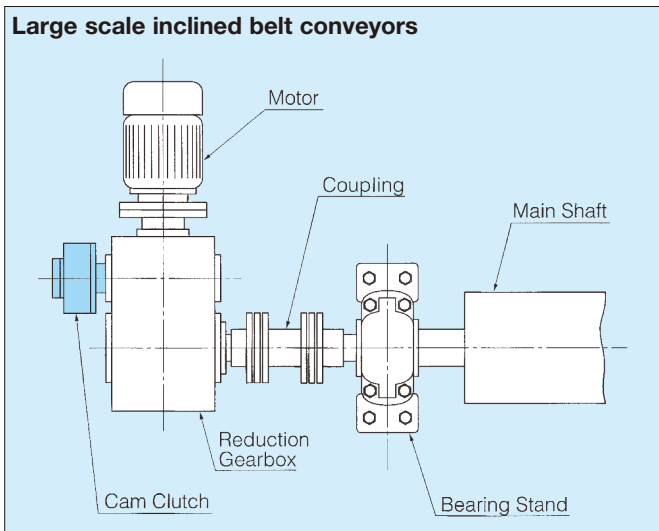

**Applicable Series**

Series	Advantage	Page
BR-HT, BR-P, BREU	<ul style="list-style-type: none"> <li>The cam is the inner race overrunning type that lifts off.</li> </ul>	54 to 66

# MZ SERIES CAM CLUTCH

## MODELS MZ 15 TO MZ 70

For General Applications

Features:

1. Prelubricated with special grease
2. No lubrication maintenance required
3. Easy installation and handling

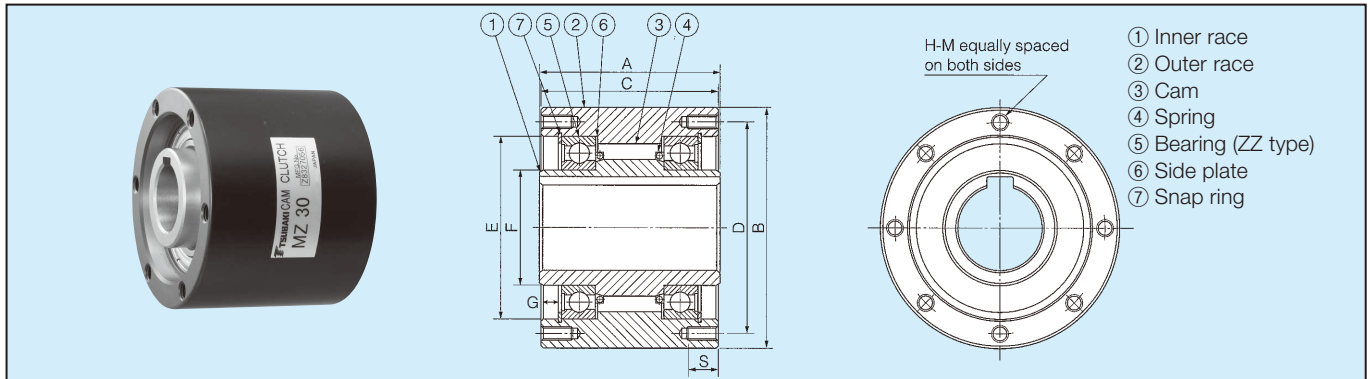

### Dimensions and Capacities

Dimensions in mm

Model	Torque Capacity (N·m)	Drag Torque (N·m)	Max. Overrunning (r/min)		Max. indexing (cycle/min)	Bore Size		A	B	C	PCD D	E (M6)	F	G	H-M No. of Tapped Holes× Size×Pitch	S	Weight (kg)
			Inner Race	Outer Race		Dia. (H7)	Keyway										
MZ15	186	0.20	2200	900	150	15	5×2.3	62	68	60	58	47	25	5.5	6×M5×P0.8	10	1.4
MZ17	215	0.20	2000	800	150	17	5×2.3	66	75	64	64	52	28	6.3	6×M5×P0.8	10	1.8
MZ20	323	0.29	1900	700	150	20	6×2.8	67	80	65	68	55	30	7.6	6×M6×P1.0	12	2.0
MZ30-22	735	0.39	1800	500	150	22	6×2.8	82	100	80	88	75	45	8.9	6×M8×P1.25	16	3.7
MZ30-25						25	8×3.3										
MZ30						30	10×3.3										
MZ35	1080	0.49	1700	300	150	35	10×3.3	87	110	85	95	80	50	8.7	6×M8×P1.25	16	4.8
MZ45-40	1620	0.69	1700	300	150	40	12×3.3	92	125	90	110	95	60	8.4	8×M8×P1.25	16	6.2
MZ45						45	14×3.8										
MZ60-50	2110	0.98	1600	250	150	50	14×3.8	102	155	100	140	125	80	9.1	8×M8×P1.25	16	10.2
MZ60-55						55	16×4.3										
MZ60						60	18×4.4										
MZ70-65	3040	1.27	1300	250	150	65	18×4.4	105	175	103	162	145	95	8.6	8×M8×P1.25	16	13.2
MZ70						70	20×4.9										

### Installation and Usage

1. MZ Series Cam Clutch is shielded by shield bearings on both ends, packed with a special grease, and are ready for use. No additional lubricant is required.
2. For attaching pulleys, gears or sprockets to the clutches, insert hubs (with  $f_7$  tolerance of ISO R773) along the inner surface of the outer race and screw the bolts (high tension) into the tapped holes on the clutch end.

3. Recommended shaft tolerances are shown in the table on the lower left.
4. External thrust load should be supported by other devices, not by the Cam Clutch.
5. Use only a parallel key to secure the clutch to the shaft. Do not use a tapered Key.
6. When mounting the clutch onto the shaft, apply pressure to the inner race but never to the outer race. See the illustration on the right.
7. For vertical mounting, please consult TSUBAKI.
8. Ambient temperature range is  $-5^{\circ}$  to  $40^{\circ}\text{C}$ .
9. Key to be used should be in accordance with ISO R773. (DIN 6885.1)
10. Align the key to slide through the keyway smoothly before installation.

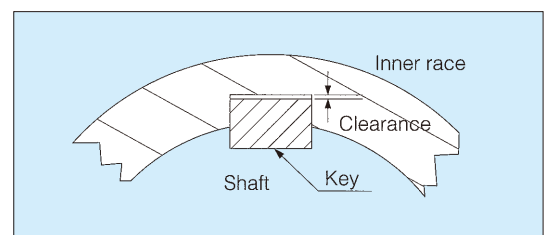

### Typical installation

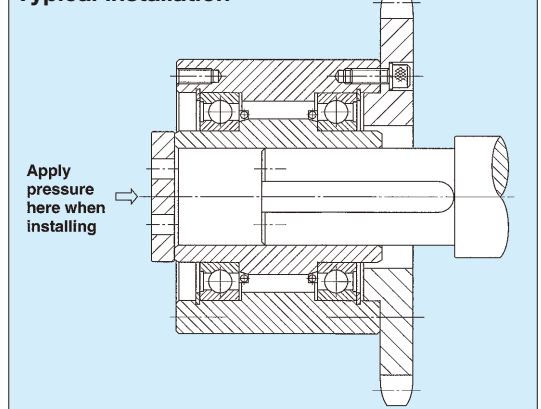

Model	Nominal diameter (mm)	Relative shaft tolerance (mm)
MZ15	15	+0 to -0.018
MZ17	17	+0 to -0.018
MZ20	20	+0 to -0.021
MZ30	30	+0 to -0.021
MZ35	35	+0 to -0.025
MZ45	45	+0 to -0.025
MZ60	60	+0 to -0.030
MZ70	70	+0 to -0.030

# MZ-G SERIES CAM CLUTCH

## MODELS MZ 15G TO MZ 70G

For General Applications

Features:

1. Outer race circumference ground finish

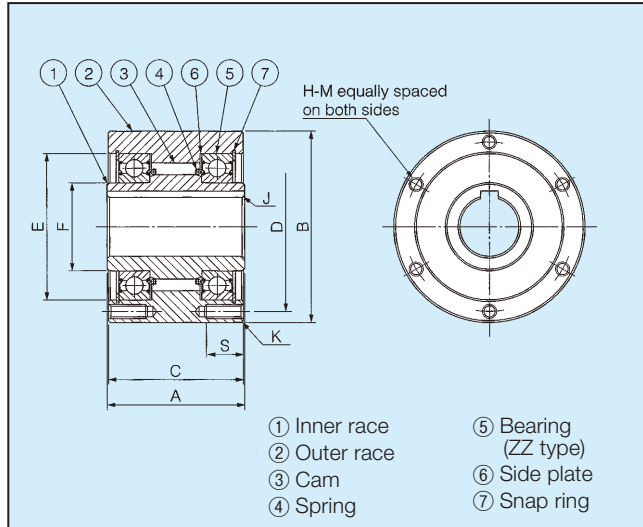

### Capacities

Model	Torque Capacity (N·m)	Max. Overrunning (r/min)		Max. indexing (cycle/min)	Drag Torque (N·m)
		Inner Race	Outer Race		
MZ15G	186	2200	900	150	0.20
MZ17G	215	2000	800	150	0.20
MZ20G	323	1900	700	150	0.29
MZ30G-22	735	1800	500	150	0.39
MZ30G-25					
MZ30G					
MZ35G	1080	1700	300	150	0.49
MZ45G-40	1620	1700	300	150	0.69
MZ45G					
MZ60G-50	2110	1600	250	150	0.98
MZ60G-55					
MZ60G					
MZ70G-65	3040	1300	250	150	1.27
MZ70G					

### Dimensions

Dimensions in mm

Model	Bore Size			A	C	B (h7)	F	E	K	PCD D	S	H-M No. of Tapped Holes× Size×Pitch	Weight (kg)
	Dia. (H7)	Keyway	Chamfer J										
MZ15G	15	5×2.3	0.8	55	53	68	25	47	1.3	58	10	6-M5×0.8	1.3
MZ17G	17	5×2.3	0.8	63	61	75	28	52	1.3	64	10	6-M5×0.8	1.7
MZ20G	20	5×2.3	0.8	64	62	80	30	55	1.3	68	12	6-M6×1.0	1.9
MZ30G-22	22	8×3.3	1.0	70	68	100	45	75	1.3	88	16	6-M8×1.25	3.2
MZ30G-25	25	8×3.3	1.0										
MZ30G	30	10×3.3	1.0										
MZ35G	35	10×3.3	1.0	78	76	110	50	80	1.3	95	16	6-M8×1.25	4.4
MZ45G-40	40	12×3.3	1.3	87	85	125	60	95	1.3	110	16	8-M8×1.25	6.2
MZ45G	45	12×3.3	1.3										
MZ60G-50	50	14×3.8	1.5	90	88	155	80	125	1.3	140	16	8-M8×1.25	9.5
MZ60G-55	55	16×4.3	1.5										
MZ60G	60	18×4.4	1.5										
MZ70G-65	65	18×4.4	1.8	105	103	175	95	145	1.3	162	16	8-M8×1.25	13.1
MZ70G	70	20×4.9	1.8										

### Installation and Usage

1. Align the key to slide through the keyway smoothly before installation.
2. When mounting sprockets or gears to the outer race, use the outer race outer dimension (dimension B) to make a centering flange in the gear or sprocket. Then attach firmly with bolts of tensile strength 10.9 or greater to the tapped holes in the outer race.
3. Please refer to MZ Series for usage and other types of installations.

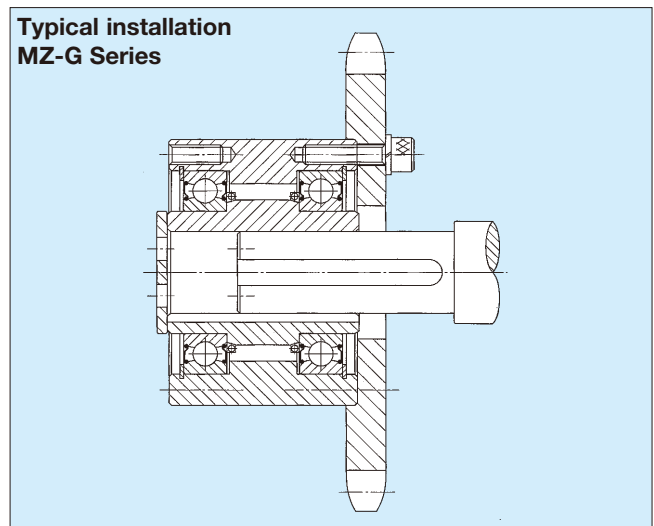

# MZEU SERIES CAM CLUTCH

## Basic type

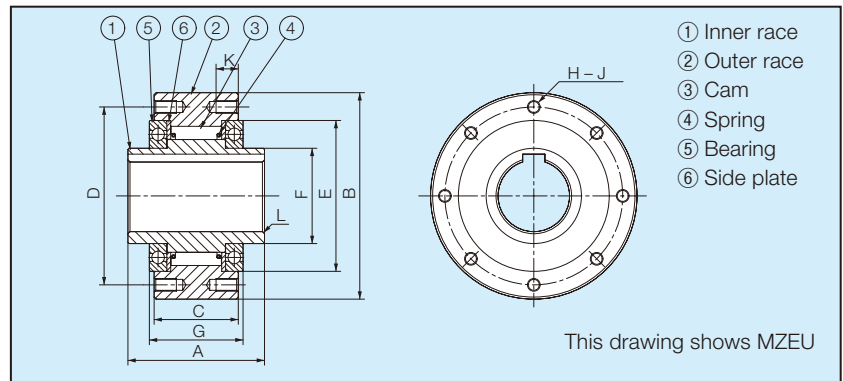
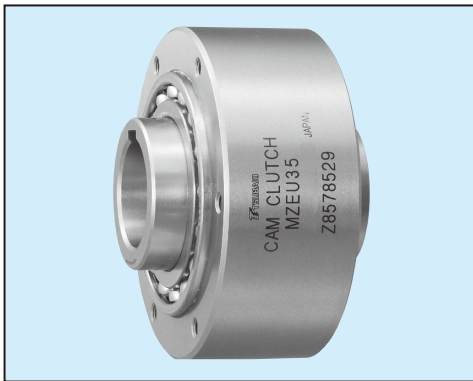

## Dimensions and Capacities

Dimensions in mm

Model	Torque Capacity (N·m)	Max. Overrunning (r/min)		Drag Torque (N·m)	Bore Size (H7)	Inner Race Keyway	A	B (h7)	C	PCD D	E	F	G	H-J	K	L	Weight (kg)
		Inner Race	Outer Race														
MZEU 12 (K)	60	2000	1000	0.20	12	4×1.8	42	62	20	51	42	20	27	3-φ5.5	—	0.8	0.5
MZEU 15 (K)	100	1800	900	0.20	15	5×2.3	52	68	28	56	47	25	32	3-M5	8	0.8	0.8
MZEU 20 (K)	245	1600	700	0.29	20	6×2.8	57	75	34	64	55	30	39	4-M5	8	0.8	1.2
MZEU 25 (K)	425	1600	600	0.33	25	8×3.3	60	90	35	78	68	40	40	4-M6	10	0.8	1.8
MZEU 30 (K)	735	1500	500	0.39	30	8×3.3	68	100	43	87	75	45	48	6-M6	10	1.0	2.6
MZEU 35 (K)	1015	1400	300	0.49	35	10×3.3	74	110	45	96	80	50	51	6-M6	12	1.0	3.2
MZEU 40 (K)	1350	1400	300	0.59	40	12×3.3	86	125	53	108	90	55	59	6-M8	14	1.3	4.8
MZEU 45 (K)	1620	1400	300	0.69	45	14×3.8	86	130	53	112	95	60	59	8-M8	14	1.3	6.2
MZEU 50 (K)	2070	1300	250	0.79	50	14×3.8	94	150	64	132	110	70	72	8-M8	14	1.3	8.2
MZEU 55 (K)	2400	1300	250	0.88	55	16×4.3	104	160	66	138	115	75	72	8-M10	16	1.5	9.5
MZEU 60 (K)	2950	1200	250	0.98	60	18×4.4	114	170	78	150	125	80	89	10-M10	16	1.5	12.3
MZEU 70 (K)	4210	1100	250	1.27	70	20×4.9	134	190	95	165	140	90	108	10-M10	16	1.8	18.1
MZEU 80 (K)	5170	800	200	1.38	80	22×5.4	144	210	100	185	160	105	108	10-M10	16	1.8	23.1
MZEU 90 (K)	12000	450	150	4.70	90	25×5.4	158	230	115	206	180	120	125	10-M12	20	2.0	28.1
MZEU100 (K)	17600	400	130	5.39	100	28×6.4	182	270	120	240	210	140	131	10-M16	24	2.0	46.3
MZEU130 (K)	24500	320	110	6.76	130	32×7.4	212	310	152	278	240	160	168	12-M16	24	2.5	70.2
MZEU150 (K)	33800	240	80	8.13	150	36×8.4	246	400	180	360	310	200	194	12-M20	32	2.5	146.3

## Installation and Usage

- Model No's. MZEU12 to MZEU80 are pre-greased and require no lubrication. The operational temperature range is  $-40^{\circ}\text{C}$  to  $+40^{\circ}\text{C}$ . Model No's. MZEU90 to MZEU150 require oil lubrication. (Refer to lubrication and maintenance on page 79 and 80).
- Model No's. MZEU12 to MZEU80 sprockets and other torque transmitting factors can be used with the standard flange. Refer to installation example 1.
- We recommend a Shaft tolerance of h7, and ISO R773 (DIN 6885.1) keyway is standard.
- Align the key to slide through the keyway smoothly before installation.
- We recommend a tolerance of E H7 for the sprocket and other parts.
- Clean the surface of both ends of the outer race and the contact surfaces of the flange, sprocket and the other parts.
- For Model No's. MZEU90 to MZEU150, apply seal adhesive to the surface of the outer race at both ends.
- Check the direction of rotation.
- When installing standard flanges, sprockets and other equipment to the clutch fit them around the bearings and screw the bolts into both ends of the outer race.
- By installing both the flange and sprocket on the opposite side, the direction of rotation can be changed.
- When mounting the clutch onto the shaft, apply pressure to inner race but never to the outer race.
- For high speed Indexing applications (More than 50 cycle/min) a strong spring type is recommended.
- Model No. MZEU  $\begin{matrix} \text{K} \\ \text{ } \end{matrix}$   $\begin{matrix} \text{ } \\ \text{ } \end{matrix}$  No Mark : No keyway on the outer race.  
K : Keyway on the outer race.
- Please refer to page 28 for dimension of keyway on the outer race.

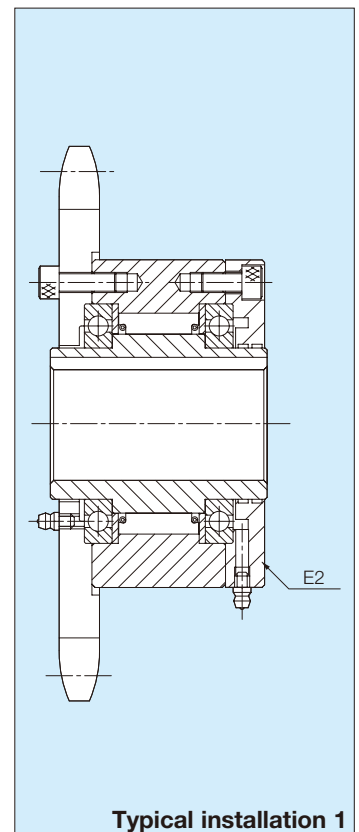

Typical installation 1

## E1 Flange + E2 Flange

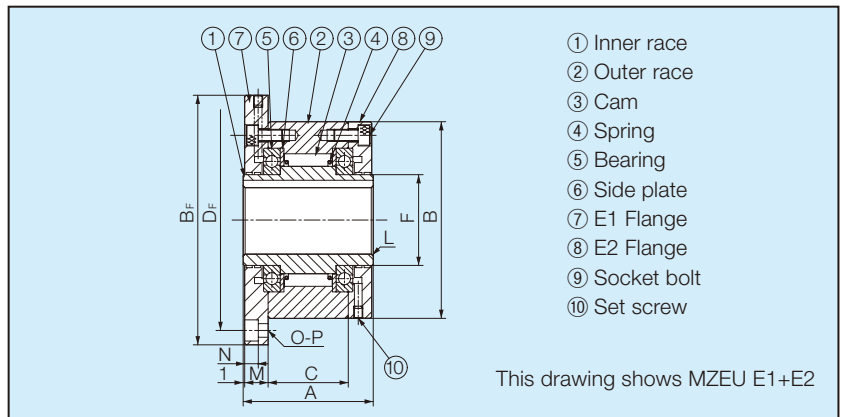

## Dimensions and Capacities

Dimensions in mm

Model	Torque Capacity (N-m)	Max. Overrunning (r/min)		Drag Torque (N-m)	Bore Size (H7)	Inner Race Keyway	A	B (h7)	B <sub>F</sub>	C	D <sub>F</sub>	F	L (C)	M	N	O-P	Weight (kg)
		Inner Race	Outer Race														
MZEU 12 (K) E1+E2	60	2000	1000	0.20	12	4×1.8	42	62	85	20	72	20	0.8	10.0	5.7	3 - φ 5.5	1.1
MZEU 15 (K) E1+E2	100	1800	900	0.20	15	5×2.3	52	68	92	28	78	25	0.8	11.0	5.7	3 - φ 5.5	1.5
MZEU 20 (K) E1+E2	245	1600	700	0.29	20	6×2.8	57	75	98	34	85	30	0.8	10.5	5.7	4 - φ 5.5	1.9
MZEU 25 (K) E1+E2	425	1600	600	0.33	25	8×3.3	60	90	118	35	104	40	0.8	11.5	6.8	4 - φ 6.6	2.9
MZEU 30 (K) E1+E2	735	1500	500	0.39	30	8×3.3	68	100	128	43	114	45	1.0	11.5	6.8	6 - φ 6.6	4.0
MZEU 35 (K) E1+E2	1015	1400	300	0.49	35	10×3.3	74	110	140	45	124	50	1.0	13.5	6.8	6 - φ 6.6	5.2
MZEU 40 (K) E1+E2	1350	1400	300	0.59	40	12×3.3	86	125	160	53	142	55	1.3	15.5	9.0	6 - φ 9.0	7.9
MZEU 45 (K) E1+E2	1620	1400	300	0.69	45	14×3.8	86	130	165	53	146	60	1.3	15.5	9.0	8 - φ 9.0	9.3
MZEU 50 (K) E1+E2	2070	1300	250	0.79	50	14×3.8	94	150	185	64	166	70	1.3	14.0	9.0	8 - φ 9.0	11.7
MZEU 55 (K) E1+E2	2400	1300	250	0.88	55	16×4.3	104	160	204	66	182	75	1.5	18.0	11.0	8 - φ 11.0	15.3
MZEU 60 (K) E1+E2	2950	1200	250	0.98	60	18×4.4	114	170	214	78	192	80	1.5	17.0	11.0	10 - φ 11.0	17.7
MZEU 70 (K) E1+E2	4210	1100	250	1.27	70	20×4.9	134	190	234	95	212	90	1.8	18.5	11.0	10 - φ 11.0	25.5
MZEU 80 (K) E1+E2	5170	800	200	1.38	80	22×5.4	144	210	254	100	232	105	1.8	21.0	11.0	10 - φ 11.0	33.2
MZEU 90 (K) E1+E2	12000	450	150	4.70	90	25×5.4	158	230	278	115	254	120	2.0	20.5	13.0	10 - φ 14.0	38.3
MZEU100 (K) E1+E2	17600	400	130	5.39	100	28×6.4	182	270	335	120	305	140	2.0	30.0	17.5	10 - φ 18.0	68.8
MZEU130 (K) E1+E2	24500	320	110	6.76	130	32×7.4	212	310	380	152	345	160	2.5	29.0	17.5	12 - φ 18.0	98.2
MZEU150 (K) E1+E2	33800	240	80	8.13	150	36×8.4	246	400	485	180	445	200	2.5	32.0	21.5	12 - φ 22.0	198.2

## Installation and Usage

- Model No's. MZEU12 to MZEU80 are pre-greased and require no lubrication. The operational temperature range is -40°C to +40°C. Model No's. MZEU90 to MZEU150 require oil lubrication. (Refer to lubrication and maintenance on page 79 and 80).
- We recommend a Shaft tolerance of h7, and ISO R773 (DIN 6885.1) keyway is standard.
- Align the key to slide through the keyway smoothly before installation.
- We recommend tolerances of B H7 or H8 for sprockets, gears and other fitted parts.
- The clutch is delivered with a Basic type Cam Clutch, E1 flange and E2 flange as separate parts.
- Clean the surface of both ends of the outer race and the contact surfaces of the flanges.
- For Model No's. MZEU90 to MZEU150, apply seal adhesive to the surface of the outer race at both ends.
- Check the direction of rotation and attach the E1 and E2 flanges to clutch.
- When installing sprockets, gears and other equipment to the clutch, fit them on the surface of the outer race and screw the bolts into the E1 flange.
- By installing both the flange and sprocket on the opposite side, the direction of rotation can be changed.
- When mounting the clutch onto the shaft, apply pressure to inner race but never to the outer race.
- For high speed Indexing applications (More than 50 cycle/min) a strong spring type is recommended.
- Model No. MZEU K  No Mark : No keyway on the outer race.  
 K : Keyway on the outer race.

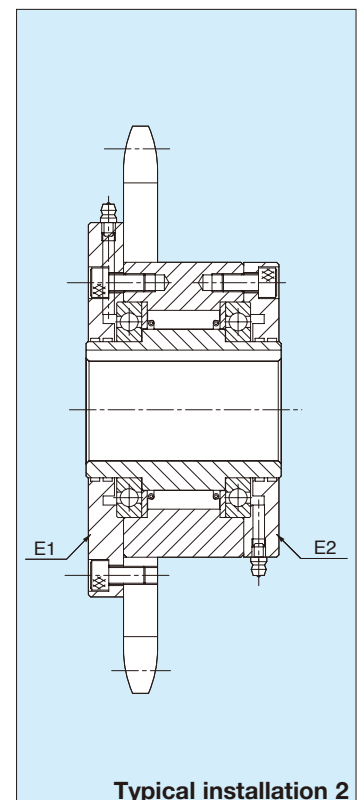

## E2 Flange + E3 Torque arm

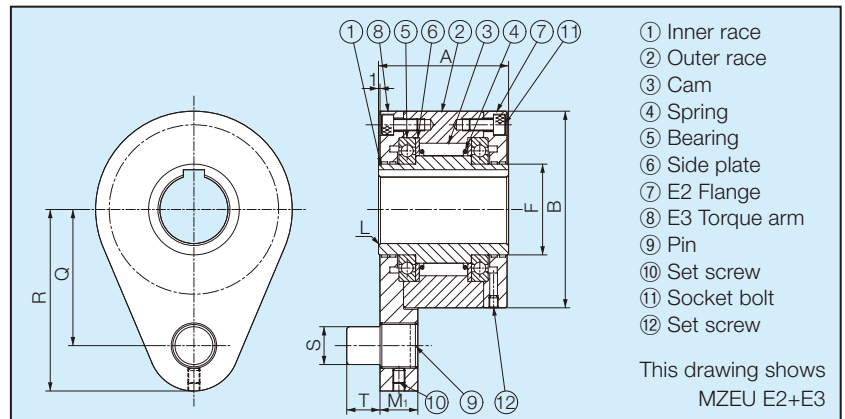
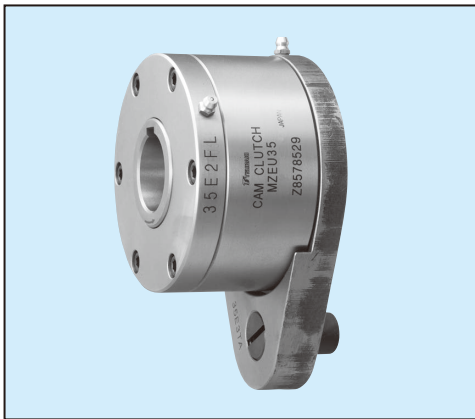

### Dimensions and Capacities

Dimensions in mm

Model	Torque Capacity (N·m)	Max. Overrunning (r/min)		Drag Torque (N·m)	Bore Size (H7)	Inner Race Keyway	A	B (h7)	F	L (C)	M1	Q	R	S	T	Weight (kg)
		Inner Race	Outer Race													
MZEU 12 (K) E2+E3	60	2000	1000	0.20	12	4×1.8	42	62	20	0.8	13.5	44	59	10	10	1.0
MZEU 15 (K) E2+E3	100	1800	900	0.20	15	5×2.3	52	68	25	0.8	13.5	47	62	10	10	1.4
MZEU 20 (K) E2+E3	245	1600	700	0.29	20	6×2.8	57	75	30	0.8	15.0	54	72	12	11	1.8
MZEU 25 (K) E2+E3	425	1600	600	0.33	25	8×3.3	60	90	40	0.8	19.0	62	84	16	14	2.7
MZEU 30 (K) E2+E3	735	1500	500	0.39	30	8×3.3	68	100	45	1.0	19.0	68	92	16	14	4.1
MZEU 35 (K) E2+E3	1015	1400	300	0.49	35	10×3.3	74	110	50	1.0	22.0	76	102	20	18	5.1
MZEU 40 (K) E2+E3	1350	1400	300	0.59	40	12×3.3	86	125	55	1.3	22.0	85	112	20	18	7.4
MZEU 45 (K) E2+E3	1620	1400	300	0.69	45	14×3.8	86	130	60	1.3	25.0	90	120	25	22	9.1
MZEU 50 (K) E2+E3	2070	1300	250	0.79	50	14×3.8	94	150	70	1.3	25.0	102	135	25	22	11.6
MZEU 55 (K) E2+E3	2400	1300	250	0.88	55	16×4.3	104	160	75	1.5	30.0	108	142	32	25	14.6
MZEU 60 (K) E2+E3	2950	1200	250	0.98	60	18×4.4	114	170	80	1.5	30.0	112	145	32	25	17.0
MZEU 70 (K) E2+E3	4210	1100	250	1.27	70	20×4.9	134	190	90	1.8	35.0	135	175	38	30	25.4
MZEU 80 (K) E2+E3	5170	800	200	1.38	80	22×5.4	144	210	105	1.8	35.0	145	185	38	30	32.6
MZEU 90 (K) E2+E3	12000	450	150	4.70	90	25×5.4	158	230	120	2.0	45.0	155	205	50	40	38.9
MZEU100 (K) E2+E3	17600	400	130	5.39	100	28×6.4	182	270	140	2.0	45.0	180	230	50	40	65.2
MZEU130 (K) E2+E3	24500	320	110	6.76	130	32×7.4	212	310	160	2.5	60.0	205	268	68	55	97.3
MZEU150 (K) E2+E3	33800	240	80	8.13	150	36×8.4	246	400	200	2.5	60.0	255	325	68	55	191.4

### Installation and Usage

1. Model No's. MZEU12 to MZEU80 are pre-greased and require no lubrication. The operational temperature range is  $-40^{\circ}\text{C}$  to  $+40^{\circ}\text{C}$ . Model No's. MZEU90 to MZEU150 require oil lubrication. (Refer to lubrication and maintenance on page 79 and 80).
2. We recommend a Shaft tolerance of h7, and ISO R773 (DIN 6885.1) keyway is standard.
3. Align the key to slide through the keyway smoothly before installation.
4. The clutch is delivered with a Basic type Cam Clutch, E2 flange and E3 torque arm as separate parts.
5. Clean the surface of the outer race at both ends and the contact surfaces of the E2 flange and the E3 torque arm.
6. For Model No's. MZEU90 to MZEU150, apply seal adhesive to the surface of the outer race at both ends.
7. Check the direction of rotation and attach the E2 flange and the E3 torque arm to the clutch.
8. By installing both the flange and sprocket on the opposite side, the direction of rotation can be changed.
9. When mounting the clutch onto the shaft, apply pressure to inner race but never to the outer race.
10. For high speed Indexing applications (More than 50 cycle/min) a strong spring type is recommended.
11. Model No. MZEU K
  - No Mark : No keyway on the outer race.
  - K : Keyway on the outer race.

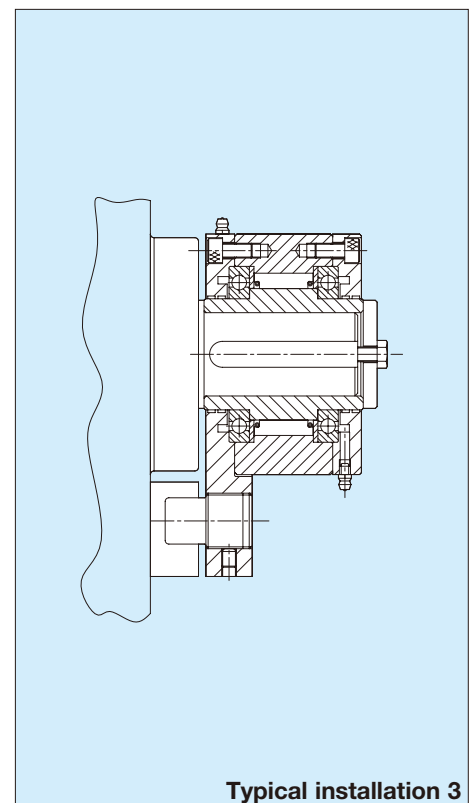

## E3 Torque arm + E4 Cover

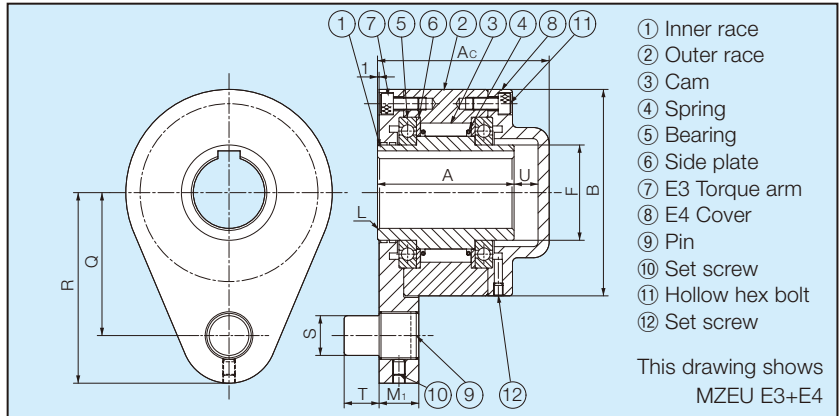
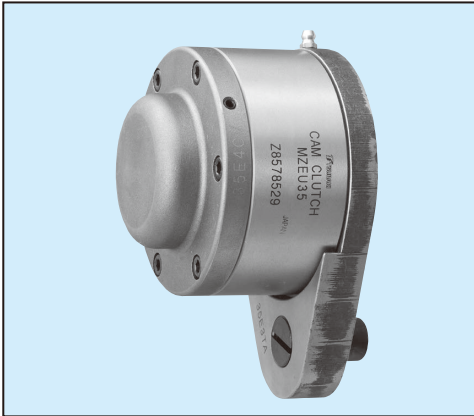

## Dimensions and Capacities

Dimensions in mm

Model	Torque Capacity (N·m)	Max. Overrunning (r/min)		Drag Torque (N·m)	Bore Size (H7)	Inner Race Keyway	A	Ac	B (h7)	F	L (C)	M1	Q	R	S	T	U	Weight (kg)
		Inner Race	Outer Race															
MZEU 12 (K) E3+E4	60	2000	1000	0.20	12	4×1.8	42	53	62	20	0.8	13.5	44	59	10	10	6	1.0
MZEU 15 (K) E3+E4	100	1800	900	0.20	15	5×2.3	52	68	68	25	0.8	13.5	47	62	10	10	10	1.5
MZEU 20 (K) E3+E4	245	1600	700	0.29	20	6×2.8	57	73	75	30	0.8	15.0	54	72	12	11	10	2.0
MZEU 25 (K) E3+E4	425	1600	600	0.33	25	8×3.3	60	76	90	40	0.8	19.0	62	84	16	14	10	2.9
MZEU 30 (K) E3+E4	735	1500	500	0.39	30	8×3.3	68	84	100	45	1.0	19.0	68	92	16	14	10	4.3
MZEU 35 (K) E3+E4	1015	1400	300	0.49	35	10×3.3	74	92	110	50	1.0	22.0	76	102	20	18	12	5.3
MZEU 40 (K) E3+E4	1350	1400	300	0.59	40	12×3.3	86	105	125	55	1.3	22.0	85	112	20	18	12	7.8
MZEU 45 (K) E3+E4	1620	1400	300	0.69	45	14×3.8	86	108	130	60	1.3	25.0	90	120	25	22	15	9.6
MZEU 50 (K) E3+E4	2070	1300	250	0.79	50	14×3.8	94	113	150	70	1.3	25.0	102	135	25	22	15	12.1
MZEU 55 (K) E3+E4	2400	1300	250	0.88	55	16×4.3	104	126	160	75	1.5	30.0	108	142	32	25	15	15.2
MZEU 60 (K) E3+E4	2950	1200	250	0.98	60	18×4.4	114	137	170	80	1.5	30.0	112	145	32	25	15	17.7
MZEU 70 (K) E3+E4	4210	1100	250	1.27	70	20×4.9	134	164.5	190	90	1.8	35.0	135	175	38	30	22.5	26.5
MZEU 80 (K) E3+E4	5170	800	200	1.38	80	22×5.4	144	168	210	105	1.8	35.0	145	185	38	30	16	33.6
MZEU 90 (K) E3+E4	12000	550	150	3.76	90	25×5.4	158	192	230	120	2.0	45.0	155	205	50	40	27	39.0
MZEU100 (K) E3+E4	17600	500	130	4.31	100	28×6.4	182	217	270	140	2.0	45.0	180	230	50	40	28	67.4
MZEU130 (K) E3+E4	24500	400	110	5.39	130	32×7.4	212	250	310	160	2.5	60.0	205	268	68	55	30	100.2
MZEU150 (K) E3+E4	33800	300	80	6.47	150	36×8.4	246	286	400	200	2.5	60.0	255	325	68	55	32	194.8

## Installation and Usage

1. Model No's. MZEU12 to MZEU80 are pre-greased and require no lubrication. The operational temperature range is  $-40^{\circ}\text{C}$  to  $+40^{\circ}\text{C}$ . Model No's. MZEU90 to MZEU150 require oil lubrication. (Refer to lubrication and maintenance on page 79 and 80).
2. We recommend a Shaft tolerance of h7, and the DIN 6885.1 keyway is standard.
3. Align the key to slide through the keyway smoothly before installation.
4. The clutch is delivered with a Basic type Cam Clutch, E3 torque arm and E4 cover as separate parts.
5. Clean the surface of both ends of the outer race and the contact surface of E3 torque arm and E4 cover.
6. For Model No's. MZEU90 to MZEU150, apply seal adhesive to the surface of the outer race at both ends.
7. Check the direction of rotation and attach the E3 torque arm to the clutch.
8. By installing both the flange and sprocket on the opposite side, the direction of rotation can be changed.
9. When mounting the clutch onto the shaft, apply pressure to inner race but never to the outer race.
10. For Model No's. MZEU12 to MZEU80, before mounting the E4 cover to the clutch attach the end plate with bolts. Refer to installation example 4.
11. For Model No's. MZEU90 to MZEU150, before mounting the cover attach the packing and end plate using sealing washers and bolts. Refer to installation example 5.
12. Model No. MZEU K  No Mark : No keyway on the outer race.  
K : Keyway on the outer race.

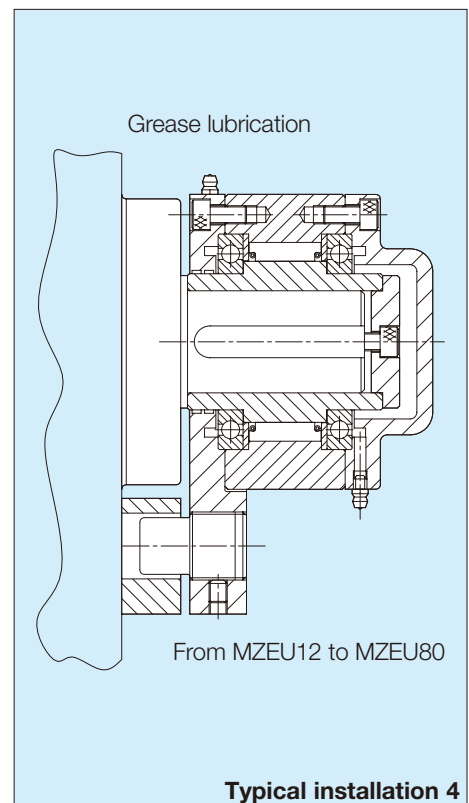

## E5 Flange + E5 Flange

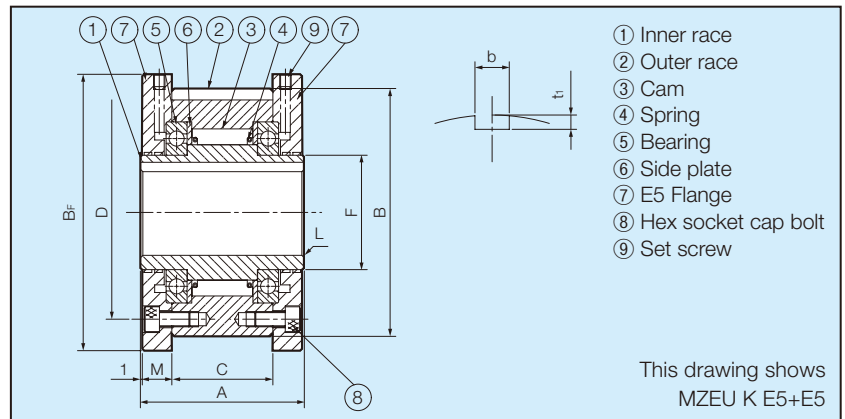
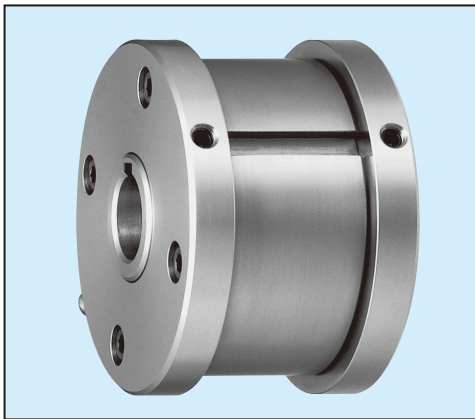

### Dimensions and Capacities

Dimensions in mm

Model	Torque Capacity (N·m)	Max. Overrunning (r/min)		Drag Torque (N·m)	Bore Size (H7)	Inner Race Keyway	A	B (h7)	B <sub>f</sub>	C	D	F	L (C)	M	b (P10)	t <sub>1</sub>	Weight (kg)
		Inner Race	Outer Race														
MZEU 12 K E5+E5	60	2000	1000	0.20	12	4×1.8	42	62	70	20	51	20	0.8	10.0	4	2.5	0.5
MZEU 15 K E5+E5	100	1800	900	0.20	15	5×2.3	52	68	76	28	56	25	0.8	11.0	5	3.0	0.8
MZEU 20 K E5+E5	245	1600	700	0.29	20	6×2.8	57	75	84	34	64	30	0.8	10.5	6	3.5	1.2
MZEU 25 K E5+E5	425	1600	600	0.33	25	8×3.3	60	90	99	35	78	40	0.8	11.5	8	4.0	1.8
MZEU 30 K E5+E5	735	1500	500	0.39	30	8×3.3	68	100	109	43	87	45	1.0	11.5	8	4.0	2.6
MZEU 35 K E5+E5	1015	1400	300	0.49	35	10×3.3	74	110	119	45	96	50	1.0	13.5	10	5.0	3.2
MZEU 40 K E5+E5	1350	1400	300	0.59	40	12×3.3	86	125	135	53	108	55	1.3	15.5	12	5.0	4.8
MZEU 45 K E5+E5	1620	1400	300	0.69	45	14×3.8	86	130	140	53	112	60	1.3	15.5	14	5.5	6.2
MZEU 50 K E5+E5	2070	1300	250	0.79	50	14×3.8	94	150	160	64	132	70	1.3	14.0	14	5.5	8.2
MZEU 55 K E5+E5	2400	1300	250	0.88	55	16×4.3	104	160	170	66	138	75	1.5	18.0	16	6.0	9.5
MZEU 60 K E5+E5	2950	1200	250	0.98	60	18×4.4	114	170	182	78	150	80	1.5	17.0	18	7.0	12.3
MZEU 70 K E5+E5	4210	1100	250	1.27	70	20×4.9	134	190	202	95	165	90	1.8	18.5	20	7.5	18.1
MZEU 80 K E5+E5	5170	800	200	1.38	80	22×5.4	144	210	222	100	185	105	1.8	21.0	22	9.0	23.1
MZEU 90 K E5+E5	12000	450	150	4.70	90	25×5.4	158	230	242	115	206	120	2.0	20.5	25	9.0	28.1
MZEU100 K E5+E5	17600	400	130	5.39	100	28×6.4	182	270	282	120	240	140	2.0	30.0	28	10.0	46.3
MZEU130 K E5+E5	24500	320	110	6.76	130	32×7.4	212	310	322	152	278	160	2.5	29.0	32	11.0	70.2
MZEU150 K E5+E5	33800	240	80	8.13	150	36×8.4	246	400	412	180	360	200	2.5	32.0	36	12.0	146.3

### Installation and Usage

1. The clutch is delivered with a Basic type Cam Clutch, two E5 flanges, and flange kit as separate parts.
2. Check the direction of rotation and attach an E5 flange to the clutch by the bolt.
3. Align the key to slide through the keyway smoothly before installation.
4. When installing sprocket, gear and other equipment to the clutch, install them on the outer race and fix the key between the equipment and the outer race.
5. We recommend a tolerance of H7 for the bore of the sprocket, gear or other equipment.
6. Attach the opposite side E5 flange to the clutch by the bolts.
7. By installing the clutch to the shaft on the opposite side, the direction of rotation can be changed.
8. When mounting the clutch onto the shaft, apply pressure to the inner race but never to the outer race.
9. For high speed indexing applications (More than 50 cycle/min) a strong spring type is recommended.
10. Refer to page 79 and 80 for other usage.
11. E5+E5 flange is available only for MZEU K model.

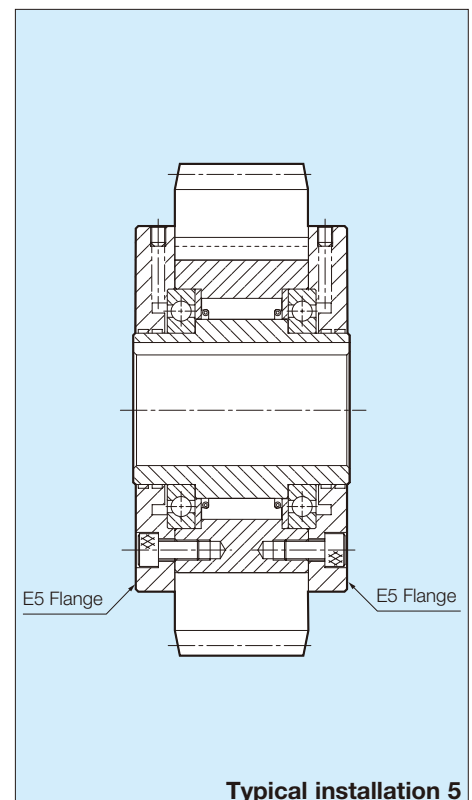

Typical installation 5

## E2 Flange + E7 Flange

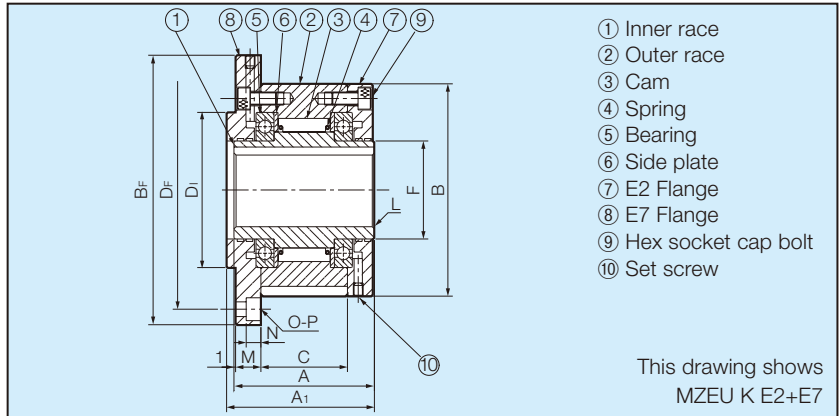
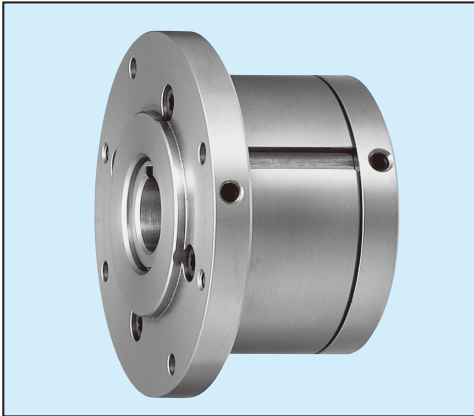

### Dimensions and Capacities

Dimensions in mm

Model	Torque Capacity (N·m)	Max. Overrunning (r/min)		Drag Torque (N·m)	Bore Size (H7)	Inner Race Keyway	A	A <sub>1</sub>	B (h7)	B <sub>F</sub>	C	D <sub>1</sub> (h7)	D <sub>F</sub>	F	L (C)	M	N	O-P	Weight (kg)
		Inner Race	Outer Race																
MZEU 12 (K) E2+E7	60	2000	1000	0.20	12	4×1.8	42	44	62	85	20	42	72	20	0.8	10.0	5.7	3-φ5.5	0.5
MZEU 15 (K) E2+E7	100	1800	900	0.20	15	5×2.3	52	54	68	92	28	47	78	25	0.8	11.0	5.7	3-φ5.5	0.8
MZEU 20 (K) E2+E7	245	1600	700	0.29	20	6×2.8	57	59	75	98	34	55	85	30	0.8	10.5	5.7	4-φ5.5	1.2
MZEU 25 (K) E2+E7	425	1600	600	0.33	25	8×3.3	60	62	90	118	35	68	104	40	0.8	11.5	6.8	4-φ6.6	1.8
MZEU 30 (K) E2+E7	735	1500	500	0.39	30	8×3.3	68	70	100	128	43	75	114	45	1.0	11.5	6.8	6-φ6.6	2.6
MZEU 35 (K) E2+E7	1015	1400	300	0.49	35	10×3.3	74	76	110	140	45	80	124	50	1.0	13.0	6.8	6-φ6.6	3.2
MZEU 40 (K) E2+E7	1350	1400	300	0.59	40	12×3.3	86	88	125	160	53	90	142	55	1.3	15.0	9.0	6-φ9.0	4.8
MZEU 45 (K) E2+E7	1620	1400	300	0.69	45	14×3.8	86	88	130	165	53	95	146	60	1.3	15.0	9.0	8-φ9.0	6.2
MZEU 50 (K) E2+E7	2070	1300	250	0.79	50	14×3.8	94	96	150	185	64	110	166	70	1.3	13.0	9.0	8-φ9.0	8.2
MZEU 55 (K) E2+E7	2400	1300	250	0.88	55	16×4.3	104	106	160	204	66	115	182	75	1.5	17.0	11.0	8-φ11.0	9.5
MZEU 60 (K) E2+E7	2950	1200	250	0.98	60	18×4.4	114	116	170	214	78	125	192	80	1.5	16.0	11.0	10-φ11.0	12.3
MZEU 70 (K) E2+E7	4210	1100	250	1.27	70	20×4.9	134	136	190	234	95	140	212	90	1.8	17.5	11.0	10-φ11.0	18.1
MZEU 80 (K) E2+E7	5170	800	200	1.38	80	22×5.4	144	146	210	254	100	160	232	105	1.8	20.0	11.0	10-φ11.0	23.1
MZEU 90 (K) E2+E7	12000	450	150	4.70	90	25×5.4	158	160	230	278	115	180	254	120	2.0	19.0	13.0	10-φ14.0	28.1
MZEU100 (K) E2+E7	17600	400	130	5.39	100	28×6.4	182	184	270	335	120	210	305	140	2.0	28.0	17.5	10-φ18.0	46.3
MZEU130 (K) E2+E7	24500	320	110	6.76	130	32×7.4	212	214	310	380	152	240	345	160	2.5	27.0	17.5	12-φ18.0	70.2
MZEU150 (K) E2+E7	33800	240	80	8.13	150	36×8.4	246	248	400	485	180	310	445	200	2.5	30.0	21.5	12-φ22.0	146.3

### Installation and Usage

1. The clutch is delivered with a Basic type Cam Clutch, E2 flange, E7 flange and each flange kit as separate parts.
2. Check the direction of rotation and attach the each flange to the clutch.
3. Align the key to slide through the keyway smoothly before installation.
4. When installing sprocket, gear and other equipment to the clutch, fit them on the surface of the outer race or flange and screw the bolt in to them.
5. By installing both option parts on the opposite side, the direction of rotation can be changed.
6. When mounting the clutch onto the shaft, apply pressure to the inner race but never to the outer race.
7. For high speed indexing applications (more than 50 cycle/min) a strong spring type is recommended.
8. Refer to page 79 and 80 for other usage.
9. Model No. MZEU **K** └── No Mark : No keyway on the outer race.  
└── K : Keyway on the outer race.

**Notes:** Do not apply a large overhung load to the outer race by using E7 flange to keep the centerline between the inner and outer race.

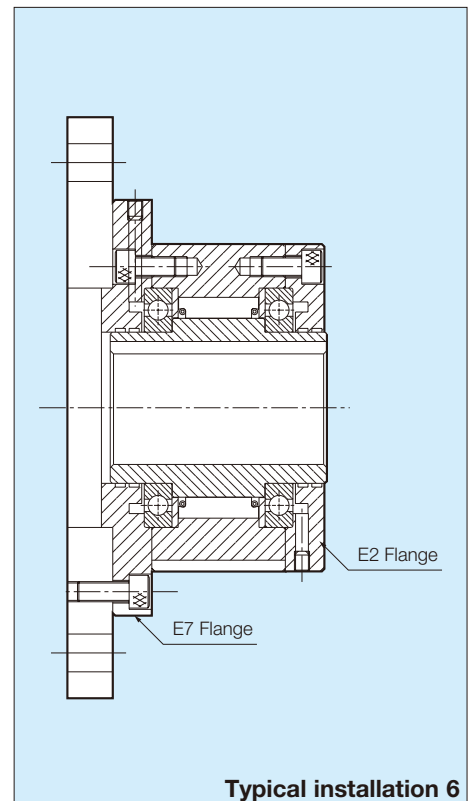

Typical installation 6



# 200 SERIES CAM CLUTCH

## MODELS B203 TO B214

### Shaft-Mounted Type

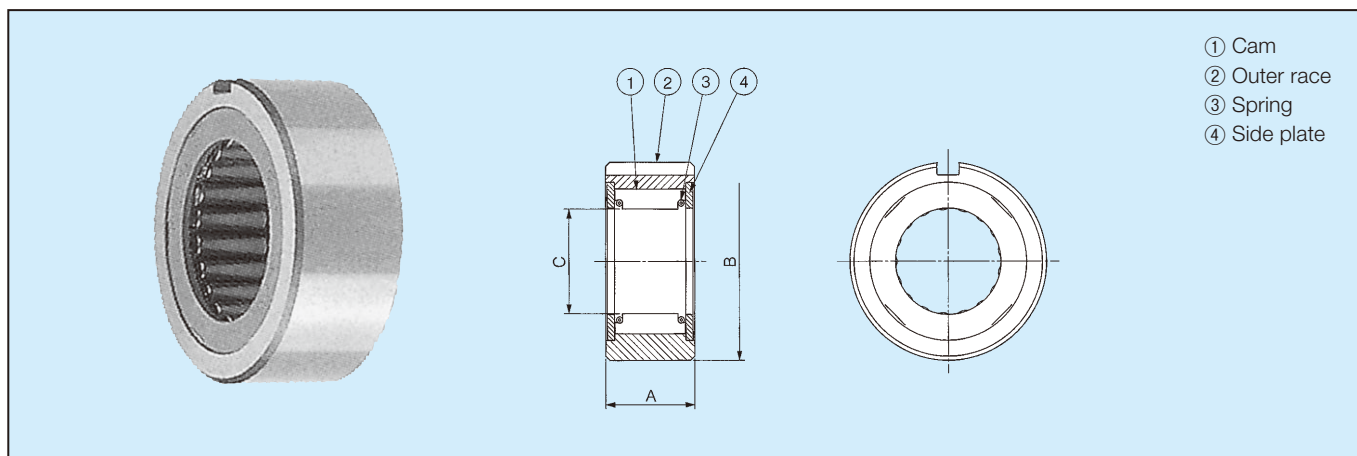

### Dimensions and Capacities

Dimensions in mm

Model	Torque Capacity (N·m)	Drag Torque (N·m)	Max. Overrunning (r/min)		Max. Indexing (cycle/min)	A (+0 to -0.06)	B	Shaft Dia. C (+0 to -0.025)	Keyway	With JIS Bearing No.	Weight (kg)
			Shaft	Outer Race							
B 203	39.2	0.10	2400	500	150	25.0	40 <sup>-0.014</sup> / <sub>-0.039</sub>	16.510	4×2.5	6203	0.23
B 204	58.8	0.10	2400	500	150	25.0	47 <sup>-0.014</sup> / <sub>-0.039</sub>	18.796	5×3	6204	0.34
B 205	98	0.20	1800	400	150	25.0	52 <sup>-0.017</sup> / <sub>-0.042</sub>	23.622	5×3	6205	0.45
B 206	235	0.20	1800	350	150	28.0	62 <sup>-0.017</sup> / <sub>-0.042</sub>	32.766	7×4	6206	0.68
B 207	372	0.20	1800	300	150	28.0	72 <sup>-0.017</sup> / <sub>-0.042</sub>	42.088	7×4	6207	0.80
B 208	549	0.20	1800	200	150	32.0	80 <sup>-0.017</sup> / <sub>-0.042</sub>	46.761	10×4.5	6208	0.91
B 209	549	0.20	1800	200	150	32.0	85 <sup>-0.020</sup> / <sub>-0.045</sub>	46.761	10×4.5	6209	0.95
B 210	784	0.29	1200	200	150	32.0	90 <sup>-0.020</sup> / <sub>-0.045</sub>	56.109	10×4.5	6210	1.00
B 211	784	0.29	1200	200	150	32.0	100 <sup>-0.020</sup> / <sub>-0.050</sub>	56.109	10×4.5	6211	1.40
B 212	1230	0.29	1200	180	150	42.0	110 <sup>-0.020</sup> / <sub>-0.050</sub>	70.029	10×4.5	6212	1.80
B 213	1230	0.29	1200	180	150	42.0	120 <sup>-0.020</sup> / <sub>-0.050</sub>	70.029	10×4.5	6213	2.30
B 214	1390	0.39	1000	180	150	42.0	125 <sup>-0.024</sup> / <sub>-0.060</sub>	79.356	12×4.5	6214	2.40

**Note:** Stronger spring type "B---SS" is available upon request. when an inner race is needed, order "B---IR".

### Installation and Usage

- 200 Series Cam Clutch is shaft mounted, so the shaft on which the clutch is mounted must be hardened to Rc 56-60 and 1.5 mm case depth after grinding. Grind to 1.5S (16micro-inch) finish. The taper of this shaft should not exceed 0.01mm per 50mm.
- For installation of the clutch, mount the clutch with bearings at both sides or on one side in order to obtain concentricity between the shaft and the clutch outer race and to take up radial or thrust loads which may work on the outer race or the shaft. See the installation example.
- The clutch should be mounted on the shaft by rotating it in the direction marked by the arrow shown on the clutch plate. Do not apply shock to

the clutch by hammering.

- The clutches have the same outside diameters as the bearings shown in the table above. Bore tolerance of the housing in which the clutch is assembled should be within the range shown in the table below.
- For indexing, oil lubrication is recommended.
- Concentricity of the housing bore and shaft should be within 0.05 mm.
- Key profile should be in accordance with JIS B1301-1959.
- Align the key to slide through the keyway smoothly before installation.

Model	Tolerance of housing bore (mm)
B 203, B 204	+0 to +0.025
B 205, B 206, B 207, B 208	+0 to +0.030
B 210, B 211, B 212, B 213	+0 to +0.035
B 214	+0 to +0.040

### Typical installation

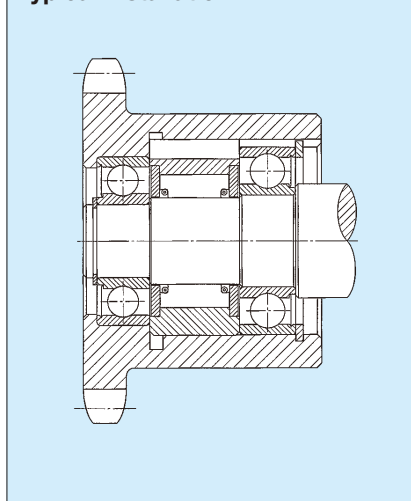

- See "information for Selection" on page 77.
- See "Lubrication and Maintenance" on page 79.

## BB SERIES CAM CLUTCH

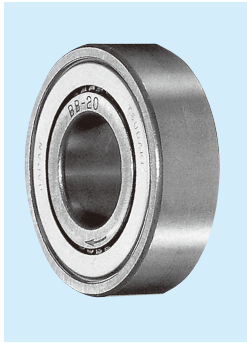

BB series

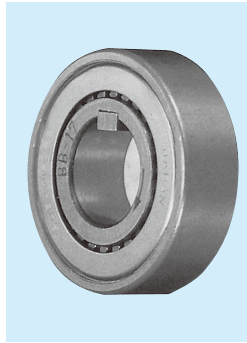

BB-1K-K series

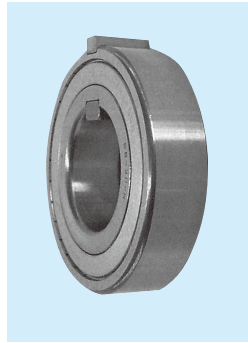

BB-2K-K series

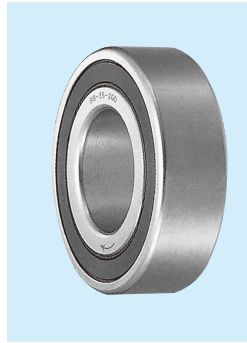

BB-2GD series

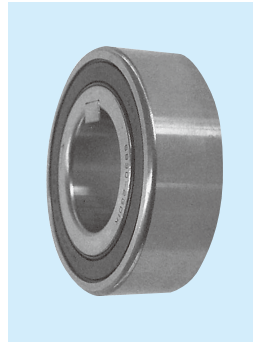

BB-2GD 1K-K series

### General information of Installation and usage for BB series Cam Clutch

1. BB series Cam Clutch is designed for press fit installation.
2. BB-1K-K and BB-2GD 1K-K series have a keyway on the inner race. Keyways, except size 25 are manufactured to DIN 6885. 3, BB40-1K-K and BB40-2GD 1K-K are manufactured to DIN 6885. 1.
3. BB-2K-K series has a keyway on both the inner and outer race.  
“-K” means keys shipped together with Cam Clutch.
4. Correct interference dimensions at the shaft and the housing must be maintained to obtain maximum bearing and clutch performance.
5. Refer to the table on next page for tolerance of the shaft and housing for each series.
6. BB, BB-1K and BB-2K Clutches, bearing supported and delivered with grease have dust seal protection against particles of 0.25mm and over, whereas BB-2GD and BB-2GD-1K clutches, 5mm wider than standard BB series, have special lip seals for effective protection against any dust.
7. The arrow on the inner race shows the direction of inner race engaging.
8. To install the clutch, use a press tool of the appropriate diameter to apply even pressure over the entire face of the inner and outer race.
9. Do not hammer or apply other shock to the clutch.
10. Make sure the housing has enough strength to withstand the pressure required for the press fitting installation of the Clutch.
11. Operating temperature range:  $-30^{\circ}\text{C}$  to  $+100^{\circ}\text{C}$  (Consult us for the temperature that exceeds this range).

### Lubrication

1. Since grease is already applied before delivery, there is no need to apply grease before use.
2. If the clutch is used with an oil lubricant, the oil lubrication should be applied inside the unit always.
3. Do not use greases or lubricants with EP additives.

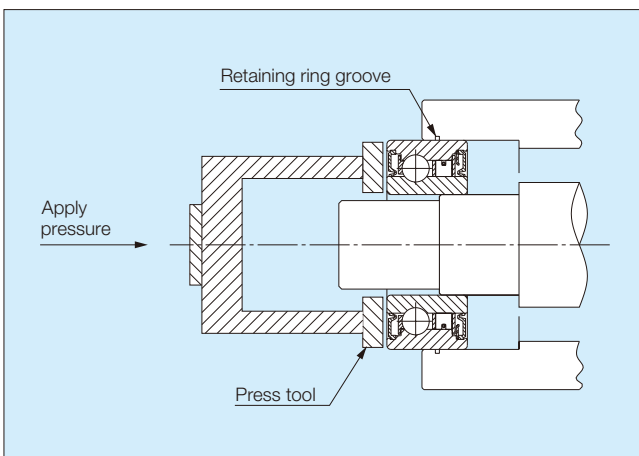

# BB SERIES CAM CLUTCH BB, BB-1K-K, BB-2K-K, BB-2GD, BB-2GD 1K-K

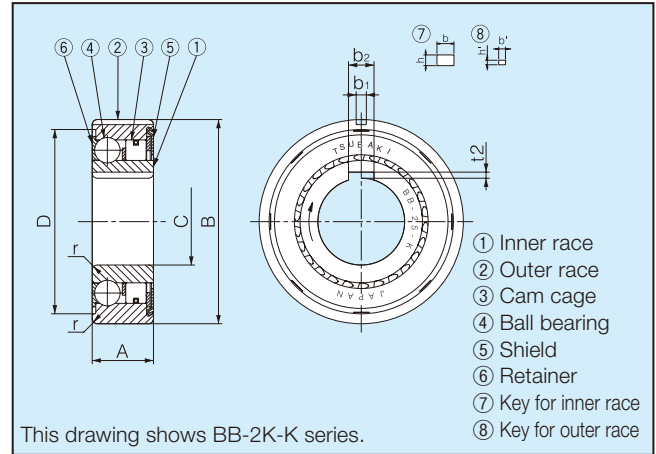
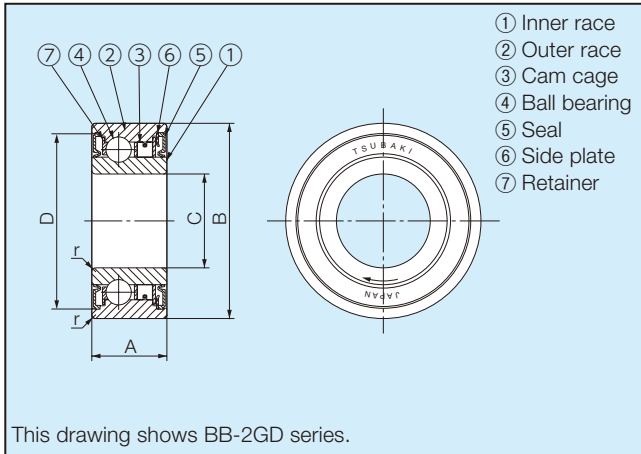

## Dimensions and Capacities

Dimensions in mm

Model	Torque Capacity (N·m)	Max. Overrunning (r/min)		Drag Torque (N·m)		A		B	C	D		r	Inner race key b×h×lengh		Outer race key b'×h'×lengh		Weight (g)		Bearing Loads (N)	
		Inner Race	Outer Race	BB BB-1K-K BB-2K-K	BB-2GD BB-2GD 1K-K	BB BB-1K-K BB-2K-K	BB-2GD BB-2GD 1K-K			BB BB-1K-K BB-2K-K	BB-2GD BB-2GD 1K-K		BB BB-1K-K BB-2K-K	BB-2GD BB-2GD 1K-K	Cr	Cor				
BB15	29	3600	2000	0.010	0.040	11	16	35	15	32.6	32.45	0.6	5×3×11	5×3×16	2×2×11	50	70	6010	3230	
BB17	43	3500	1900	0.010	0.050	12	17	40	17	36.1	36.45	0.6	5×3×12	5×3×17	2×2×12	80	100	7380	3890	
BB20	61	3000	1600	0.014	0.055	14	19	47	20	41.7	42.35	1.0	6×4×14	6×4×19	3×3×14	120	150	8950	5090	
BB25	78	2500	1400	0.017	0.055	15	20	52	25	47.1	47.05	1.0	8×5×15	8×5×20	6×4×15	150	200	11200	6560	
BB30	140	2000	1100	0.030	0.058	16	21	62	30	56.6	55.60	1.0	8×5×16	8×5×21	6×4×16	230	280	12500	8330	
BB35	173	1800	1000	0.034	0.060	17	22	72	35	64.0	64.60	1.1	10×6×17	10×6×22	8×5×17	320	410	14500	10300	
BB40	260	1800	900	0.040	0.080	22	27	80	40	71.0	71.60	1.1	12×8×22	12×8×27	10×6×22	400	600	14500	11700	

**Note:** Model No. marked on the inner race is only "K" for both "1K" and "2K". (Example: the mark "BB25-K" for both BB25-1K and BB25-2K)

## Recommended tolerance for Shaft and Housing

Dimensions in mm

Model	Shaft Dia.	Housing Dia.	Model	Shaft Dia.	Housing Dia.	Model	Shaft Dia.	Housing Dia.
BB15	15 <sup>+0.023</sup> / <sub>+0.012</sub>	35 <sup>-0.012</sup> / <sub>-0.028</sub>	BB15-1K-K	15 <sup>-0.008</sup> / <sub>-0.028</sub>	35 <sup>-0.012</sup> / <sub>-0.028</sub>	BB15-2K-K	15 <sup>-0.008</sup> / <sub>-0.028</sub>	35 <sup>-0.002</sup> / <sub>-0.018</sub>
BB17	17 <sup>+0.023</sup> / <sub>+0.012</sub>	40 <sup>-0.012</sup> / <sub>-0.028</sub>	BB17-1K-K	17 <sup>-0.008</sup> / <sub>-0.028</sub>	40 <sup>-0.012</sup> / <sub>-0.028</sub>	BB17-2K-K	17 <sup>-0.008</sup> / <sub>-0.028</sub>	40 <sup>-0.002</sup> / <sub>-0.018</sub>
BB20	20 <sup>+0.028</sup> / <sub>+0.015</sub>	47 <sup>-0.012</sup> / <sub>-0.028</sub>	BB20-1K-K	20 <sup>-0.010</sup> / <sub>-0.031</sub>	47 <sup>-0.012</sup> / <sub>-0.028</sub>	BB20-2K-K	20 <sup>-0.010</sup> / <sub>-0.031</sub>	47 <sup>-0.003</sup> / <sub>-0.022</sub>
BB25	25 <sup>+0.028</sup> / <sub>+0.015</sub>	52 <sup>-0.014</sup> / <sub>-0.033</sub>	BB25-1K-K	25 <sup>-0.010</sup> / <sub>-0.031</sub>	52 <sup>-0.014</sup> / <sub>-0.033</sub>	BB25-2K-K	25 <sup>-0.010</sup> / <sub>-0.031</sub>	52 <sup>-0.003</sup> / <sub>-0.022</sub>
BB30	30 <sup>+0.028</sup> / <sub>+0.015</sub>	62 <sup>-0.014</sup> / <sub>-0.033</sub>	BB30-1K-K	30 <sup>-0.010</sup> / <sub>-0.031</sub>	62 <sup>-0.014</sup> / <sub>-0.033</sub>	BB30-2K-K	30 <sup>-0.010</sup> / <sub>-0.031</sub>	62 <sup>-0.003</sup> / <sub>-0.022</sub>
BB35	35 <sup>+0.033</sup> / <sub>+0.017</sub>	72 <sup>-0.014</sup> / <sub>-0.033</sub>	BB35-1K-K	35 <sup>-0.012</sup> / <sub>-0.037</sub>	72 <sup>-0.014</sup> / <sub>-0.033</sub>	BB35-2K-K	35 <sup>-0.012</sup> / <sub>-0.037</sub>	72 <sup>-0.006</sup> / <sub>-0.025</sub>
BB40	40 <sup>+0.033</sup> / <sub>+0.017</sub>	80 <sup>-0.014</sup> / <sub>-0.033</sub>	BB40-1K-K	40 <sup>-0.012</sup> / <sub>-0.037</sub>	80 <sup>-0.014</sup> / <sub>-0.033</sub>	BB40-2K-K	40 <sup>-0.012</sup> / <sub>-0.037</sub>	80 <sup>-0.006</sup> / <sub>-0.025</sub>

## Recommended dimensions of keyways

Dimensions in mm

Model	b <sub>2</sub> (js10)	t <sub>1</sub>	t <sub>2</sub>	b <sub>1</sub> (js9)	t <sub>3</sub>	t <sub>4</sub>
BB15-1K-K	5.0	1.9 <sup>+0.1</sup> / <sub>0</sub>	1.2 <sup>+0.3</sup> / <sub>0</sub>	—	—	—
BB15-2K-K				2.0	0.6 <sup>0</sup> / <sub>+0.1</sub>	1.6 <sup>+0.3</sup> / <sub>0</sub>
BB17-1K-K	5.0	1.9 <sup>+0.1</sup> / <sub>0</sub>	1.2 <sup>+0.3</sup> / <sub>0</sub>	—	—	—
BB17-2K-K				2.0	1.0 <sup>0</sup> / <sub>+0.1</sub>	1.2 <sup>+0.3</sup> / <sub>0</sub>
BB20-1K-K	6.0	2.5 <sup>+0.1</sup> / <sub>0</sub>	1.6 <sup>+0.3</sup> / <sub>0</sub>	—	—	—
BB20-2K-K				3.0	1.5 <sup>0</sup> / <sub>+0.1</sub>	1.8 <sup>+0.3</sup> / <sub>0</sub>
BB25-1K-K	8.0	3.6 <sup>+0.1</sup> / <sub>0</sub>	1.5 <sup>+0.3</sup> / <sub>0</sub>	—	—	—
BB25-2K-K				6.0	2.0 <sup>0</sup> / <sub>+0.1</sub>	2.3 <sup>+0.3</sup> / <sub>0</sub>
BB30-1K-K	8.0	3.1 <sup>+0.2</sup> / <sub>0</sub>	2.0 <sup>+0.3</sup> / <sub>0</sub>	—	—	—
BB30-2K-K				6.0	2.0 <sup>0</sup> / <sub>+0.1</sub>	2.3 <sup>+0.3</sup> / <sub>0</sub>
BB35-1K-K	10.0	3.7 <sup>+0.2</sup> / <sub>0</sub>	2.4 <sup>+0.3</sup> / <sub>0</sub>	—	—	—
BB35-2K-K				8.0	2.5 <sup>0</sup> / <sub>+0.1</sub>	2.8 <sup>+0.3</sup> / <sub>0</sub>
BB40-1K-K	12.0	5.0 <sup>+0.2</sup> / <sub>0</sub>	3.3 <sup>+0.3</sup> / <sub>0</sub>	—	—	—
BB40-2K-K				10.0	3.0 <sup>0</sup> / <sub>+0.2</sub>	3.3 <sup>+0.3</sup> / <sub>0</sub>

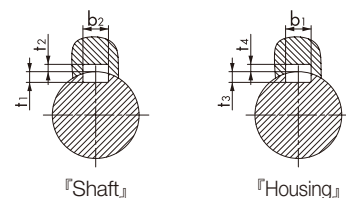

**Note:** The dimension of t<sub>2</sub> for BB25-1K-K, BB25-2K-K and BB25-2GD 1K-K is 0.5 mm shallow compared to DIN 6885. 3. Process the keyway on the shaft 0.5 mm deeply to use DIN standard key. All other models are dimensionally interchangeable with competitors.

# TSS SERIES CAM CLUTCH

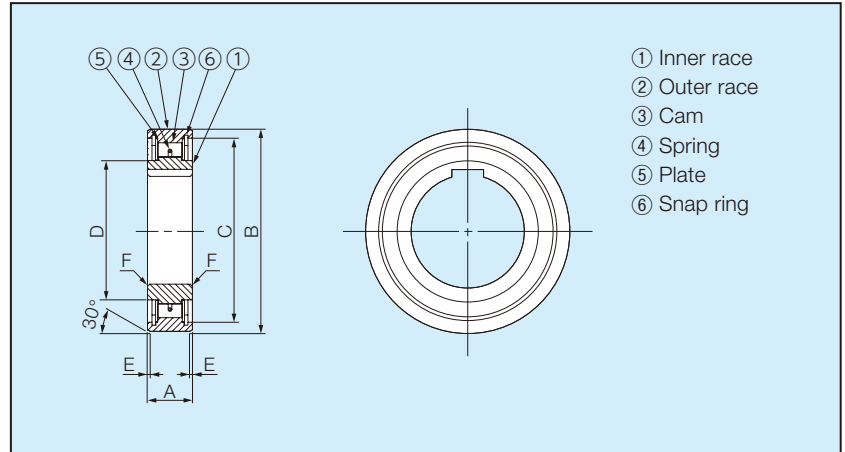

## Dimensions and Capacities

Dimensions in mm

Model	Torque Capacity (N·m)	Max. Overrunning (r/min)		Drag Torque (N·m)	Bore Size (H7)	Keyway	A	B	C	D	E	F	Weight (g)
		Inner Race	Outer Race										
TSS 8	6.7	6000	3000	0.005	8	2×1.0	8	24	22.2	11.4	0.6	0.6	14
TSS10	12	4500	2300	0.007	10	3×1.4	9	30	27	15.6	0.6	0.6	27
TSS12	17	4000	2000	0.009	12	4×1.8	10	32	29.5	18	0.6	0.6	31
TSS15	22	3500	1800	0.01	15	5×1.2	11	35	32	20.6	0.6	0.6	39
TSS20	41	2600	1300	0.01	20	6×1.6	14	47	40	26.7	0.8	0.8	115
TSS25	56	2200	1100	0.02	25	8×2.0	15	52	45	32	0.8	0.8	140
TSS30	105	1800	900	0.03	30	8×2.0	16	62	55	40	0.8	1.0	215
TSS35	136	1600	800	0.03	35	10×2.4	17	72	63	45	0.8	1.0	300
TSS40	296	1400	700	0.18	40	12×2.2	18	80	72	50	0.8	1.0	425
TSS45	347	1300	650	0.21	45	14×2.1	19	85	75.5	57	1.2	1.0	495
TSS50	403	1200	600	0.22	50	14×2.1	20	90	82	62	1.2	1.0	545
TSS60	649	910	460	0.33	60	18×2.3	22	110	100	80	1.2	1.5	950

## Installation and Usage

- The TSS Series Cam Clutch is designed for press fit installation. Correct interference dimensions must be maintained to obtain maximum clutch performance. The internal diameter of the housing should meet the H7 tolerance. Refer to item 8 in the installation and usage of BB Series Cam Clutch for information on the installation method.
- Make sure the housing has enough strength to withstand the pressure required for the press fitting installation of the clutch.
- Align the key to slide through the keyway smoothly before installation.
- When installing the clutch, mount it with a type 62 bearing to avoid radial force, since this clutch does not have any bearing support.
- Confirm the direction of rotation before installation.
- The recommended shaft tolerance is h7, and the key profile should be in accordance with the following standard.
  - TSS 8 ~ 12.....DIN 6885. 1
  - TSS 15 ~ 60.....DIN 6885. 3
- Suitable surface pressure of the key should be selected according to your company design standards.

## Lubrication

- Oil lubrication is recommended.
- Do not use greases or lubricants with EP additives.

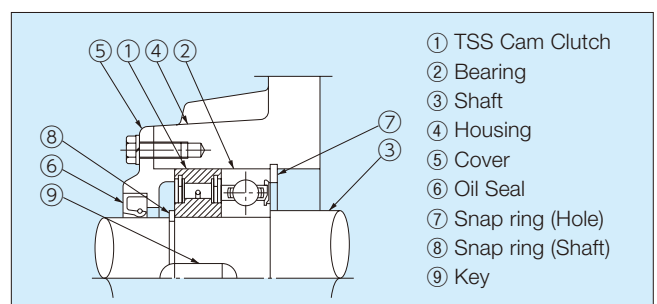

# TFS SERIES CAM CLUTCH

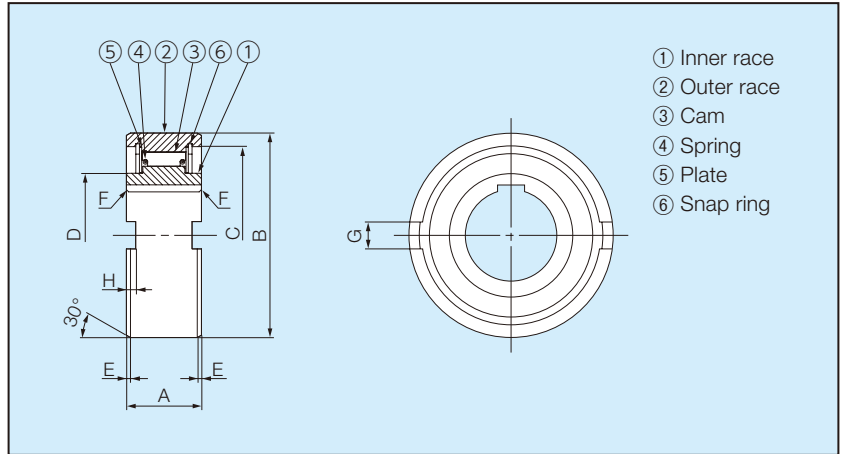

## Dimensions and Capacities

Dimensions in mm

Model	Torque Capacity (N·m)	Max. Overrunning (r/min)		Drag Torque (N·m)	Bore Size (H7)	Keyway	A	B	C	D	E	F	G	H	Weight (g)
		Inner Race	Outer Race												
TFS12	18	4500	2300	0.04	12	4×1.8	13	35	30	18	0.6	0.3	4	1.4	68
TFS15	28	3500	1800	0.06	15	5×1.2	18	42	36	22	0.8	0.3	5	1.8	120
TFS17	50	3200	1600	0.11	17	5×1.2	19	47	38	22	1.2	0.8	5	2.3	150
TFS20	84	2500	1300	0.18	20	6×1.6	21	52	45	27	1.2	0.8	6	2.3	220
TFS25	128	2000	1000	0.19	25	8×2.0	24	62	52	35	1.2	0.8	8	2.8	360
TFS30	200	1600	800	0.21	30	8×2.0	27	72	62	40	1.8	1.0	10	2.5	530
TFS35	475	1400	700	0.42	35	10×2.4	31	80	70	48	1.8	1.0	12	3.5	790
TFS40	607	1300	650	0.46	40	12×2.2	33	90	78	54.5	1.8	1.0	12	4.1	1050
TFS45	756	1100	550	0.56	45	14×2.1	36	100	85.3	59	1.8	1.0	14	4.6	1370
TFS50	1124	1000	500	0.60	50	14×2.1	40	110	92	65	1.8	1.0	14	5.6	1900
TFS60	1975	840	420	0.87	60	18×2.3	46	130	110	84	2.6	1.5	18	5.5	3110
TFS70	2514	750	380	0.91	70	20×2.7	51	150	125	91	2.6	1.5	20	6.9	4390
TFS80	3924	670	340	1.22	80	22×3.1	58	170	140	100	2.6	1.5	20	7.5	6440

## Installation and Usage

- The outer race of the TFS Series Cam Clutch is designed for press fit installation to the housing. Correct interference dimensions of the outer race must be maintained to obtain maximum clutch performance. The internal diameter of the housing should meet the H7 tolerance. Keyways should be made in the end faces of the clutch for proper installation. Refer to item 8 in the installation and usage of BB Series Cam Clutch for information on the installation method. If the tolerance of the internal diameter of the housing is K6, keyways are not required on the end faces of the clutch.
- Make sure the housing has enough strength to withstand the pressure required for the press fitting installation of the clutch.
- Align the key to slide through the keyway smoothly before installation.
- When installing the clutch, mount it with a type 63 bearing to avoid radial force, since this clutch does not have any bearing support.
- The clutch should be mounted on the shaft by rotating it in the direction marked by the arrow shown on the clutch plate. The arrow shows inner race engagement direction.
- The recommended shaft tolerance is h7, and the key profile should be in accordance with the following standard.
  - TFS 12 .....DIN 6885. 1
  - TFS 15 ~ 80 .....DIN 6885. 3
- Suitable surface pressure of the key should be selected according to your company design standards.

## Lubrication

- Oil lubrication is recommended.
- Do not use greases or lubricants with EP additives.

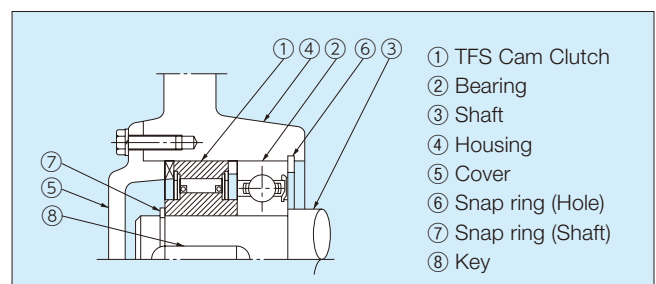

# PB SERIES CAM CLUTCH

## MODELS PB3 TO PB14

### For General Applications



### Dimensions and Capacities

Dimensions in mm

Model	Torque Capacity (N·m)	Drag Torque (N·m)	Max. Overrunning (r/min)		Max. Indexing (cycle/min)	Bore Size		A	B	C (h7)	D	E	F	G	Outer Race Keyway		Weight (kg)	Lubrication Filler Plug Size×Pitch
			Inner Race	Outer Race		Dia. (J7)	Keyway								K	L		
PB 3	29.4	0.20	1800	900	150	10	4×1.5	50	50	23	22	25	21	25.7	4×2.5	16	0.23	M6×P1.0
PB 5	147	0.20	1800	900	150	16	5×2.0	70	60	32	32	35	25	38.8	5×3.0	20	0.58	M6×P1.0
PB 6	382	0.20	1500	800	150	20	5×2.0	82	73	38	38	37	33	41.0	5×3.0	27	1.1	M6×P1.0
PB 8	568	0.29	1200	650	150	25	7×3.0	85	83	45	40	45	33	42.0	7×4.0	27	1.6	M6×P1.0
PB 10	843	0.39	1000	400	150	31.5	10×3.5	92	95	60	41	56	37	44.0	10×4.5	28	2.5	M6×P1.0
PB 12	1530	0.39	800	300	150	40	10×3.5	100	113	65	50	66	37	52.6	10×4.5	29	3.6	M6×P1.0
PB 14	2110	0.59	700	300	150	45	12×3.5	112	133	75	54	76	41	57.3	12×4.5	30	6.0	M6×P1.0

**Note:** Stronger spring type "PB-SS" is available upon request.

### Installation and Usage

- Concentricities of the inner race and the outer race are maintained by the plain bearing located between the outer race and the shaft. Radial load which works on the outer race is also supported by this plain bearing. The shaft must therefore be extended through the clutch outer race end.
- Recommended shaft tolerances are as follows:

Model	Tolerance (mm)
PB 3, PB 5, PB 6, PB 8	+0 to -0.013
PB 10, PB 12, PB 14	+0 to -0.016

- Do not use the PB Series Cam Clutch as a coupling. Use with a flexible coupling when connecting two shafts.
- Specify right (RH) or left hand (LH) inner race drive viewed from the end marked by the arrow in the illustration above. Check if the rotation of the clutch is correct before being run-in.
- For indexing use, oil lubrication is recommended.
- Key to be used should be in accordance with JIS B1301-1959
- Align the key to slide through the keyway smoothly before installation.
- Thrust load should be supported by other devices, not by the Cam Clutch.
- The bore of the driven member, such as the sprocket on the clutch outer race, should meet H6 or H7 tolerance of the JIS standard.

- When selecting the clutch, see "Information for Selection" on page 77. For lubrication, see "Lubrication and Maintenance" on page 79.

### Typical installation

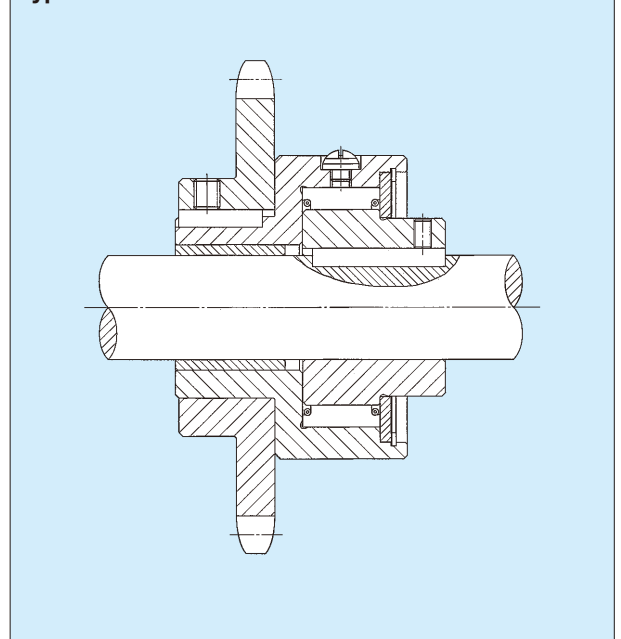

# LD SERIES CAM CLUTCH

## MODELS LD 04 TO LD 08

For Light Duty at Low Speed

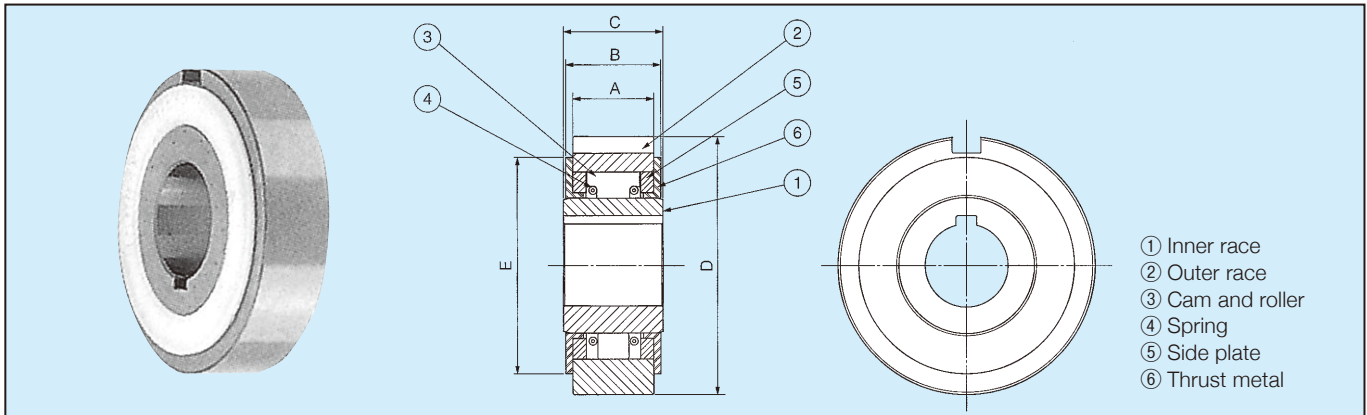

### Dimensions and Capacities

Dimensions in mm

Model	Torque Capacity (N·m)	Drag Torque (N·m)	Max. Overrunning (r/min) Inner Race	Max. Indexing (cycle/min)	Max. Radial Load When Overrunning (kgf)	Bore Size		A	B	C	D	E	Outer Race Keyway	Weight (kg)
						Dia. (H7)	Keyway							
LD 04	5.88	0.20	300	100	20	10	4×1.5	19.5	23.9	24	47 <sup>-0.014</sup> <sub>-0.039</sub>	40	5×3	0.25
LD 05	9.8	0.29	300	100	30	14	5×2	19.5	23.9	24	52 <sup>-0.017</sup> <sub>-0.042</sub>	45	5×3	0.30
LD 06	19.6	0.29	200	100	50	20	5×2	19.5	23.9	24	62 <sup>-0.017</sup> <sub>-0.042</sub>	52	7×4	0.40
LD 07	29.4	0.39	200	100	70	25	7×3	19.5	23.9	24	72 <sup>-0.017</sup> <sub>-0.042</sub>	62	7×4	0.55
LD 08	49	0.49	200	100	80	30	7×3	19.5	23.9	24	80 <sup>-0.017</sup> <sub>-0.042</sub>	70	10×4.5	0.65

**Note:** Weaker Spring type "LD---WS" is available upon request.

### Installation and Usage

- LD Series Cam Clutch is prelubricated with special grease and are ready for use. No additional lubricant is required.
- When installing the clutch on the shaft, press the clutch inner race slightly with a soft hammer to prevent the clutch outer race from slipping away from the inner race.
- Be sure to attach the plate. This prevents the outer race from slipping away from the inner race. See recommended dimensions of the plate listed on the right.
- For lubrication, coat the plate and thrust metal with grease.
- Never apply thrust loads to the clutch. Other devices should be provided to take up thrust loads applied to the clutch.
- Key should be in accordance with JIS B1301-1959.
- Align the key to slide through the keyway smoothly before installation.
- The bores of the pulley, sprocket, etc., should have a tolerance of H6 or H7.
- See "Information for Selection" on page 77.

### Recommended Plate Dimensions

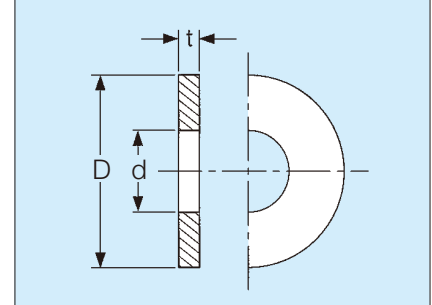

Dimensions in mm

Model	t	d	D
LD 04	2	10	40
LD 05	2	14	45
LD 06	3	20	52
LD 07	3	25	62
LD 08	3	30	70

### Typical installation

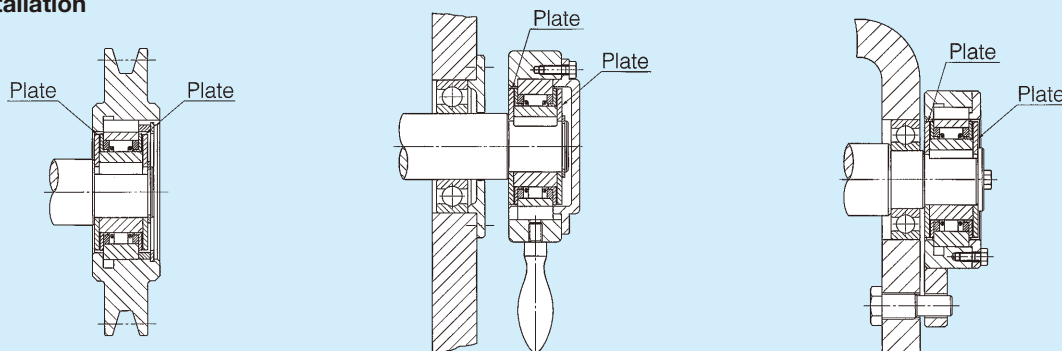

# MDEU SERIES CAM CLUTCH

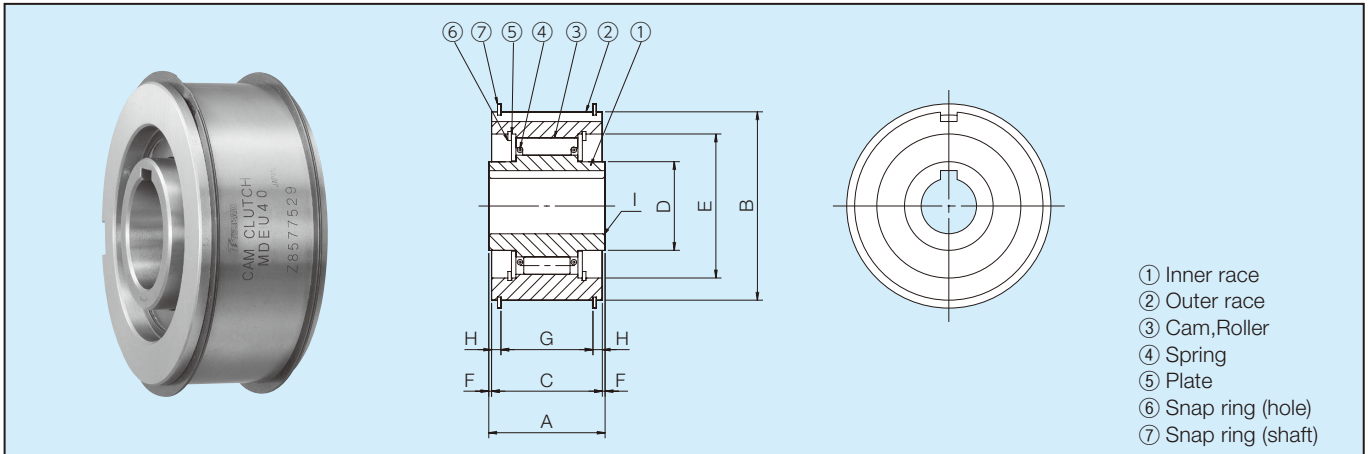

## Dimensions and Capacities

Dimensions in mm

Model	Torque Capacity (N·m)	Max. Overrunning (r/min) Inner Race	Max. Indexing (cycle/min)	Max. Radial Load When Overrunning (N)	Bore Size (H7)	Inner race Keyway	A	B (h7)	C	D	E	F	G	H	I	Outer race Keyway	Weight (kg)
MDEU15	70	600	100	610	15	5×2.3	39	55	37	25	42	1	30	3.5	0.8	5×3	0.52
MDEU20	150	500	100	910	20	6×2.8	42	68	40	32	52	1	33	3.5	0.8	6×3.5	0.88
MDEU25	230	450	100	1060	25	8×3.3	42	80	40	40	65	1	33	3.5	0.8	8×4	1.1
MDEU30	390	400	100	1400	30	8×3.3	50	90	48	45	72	1	36	6	1	8×4	1.7
MDEU35	460	350	100	1500	35	10×3.3	50	100	48	50	80	1	36	6	1	10×5	2.1
MDEU40	530	350	100	1580	40	12×3.3	50	110	48	55	78	1	36	6	1	12×5	2.7
MDEU45	690	300	100	1770	45	14×3.8	50	120	48	65	88	1	36	6	1	14×5.5	3.2
MDEU50	870	300	100	1880	50	14×3.8	50	130	48	70	95	1	36	6	1	14×5.5	3.8
MDEU55	1100	250	100	2850	55	16×4.3	60	140	58	80	105	1	46	6	1.5	16×6	5.3
MDEU60	1500	250	100	3060	60	18×4.4	60	150	58	90	115	1	46	6	1.5	18×7	6.1
MDEU70	1900	200	100	3470	70	20×4.9	60	170	58	100	125	1	46	6	1.5	20×7.5	7.9
MDEU80	2300	200	100	3600	80	22×5.4	60	190	58	110	140	1	46	6	1.5	22×9	9.7

## Installation and Usage

- The bores of the pulley, sprocket, etc., should have a tolerance of H6 or H7.
- Built in roller type bearing, due to the structure of cam and roller.
- When installing the Cam Clutch on the shaft, press the clutch inner race slightly.
- Never apply thrust loads to the Cam Clutch. Other devices should be provided to take up thrust loads applied to the Cam Clutch.
- In case of large radial loads applied to the Cam Clutch like installing with pulley, another bearing should be prepared so that the point of the loads can be hanged on the bearing.
- Key should be in accordance with ISO R773 (DIN 6885.1). Note that the keyway dimensions of outer race is not in accordance with the keyway dimensions which mentioned in ISO R773 (DIN 6885.1).
- Align the key to slide through the keyway smoothly before installation.
- See "Information for lubrication and maintenance" on page 79.
- In case of using the Cam Clutch in a dusty atmosphere, or preventing the Cam Clutch from grease leakage, MDEU-2GD (Cam Clutch with dust seal type) is available as option. Note that the maximum overrunning speed of Cam Clutch with dust seal type is approximately 80% compared with that of the standard model.

### Option

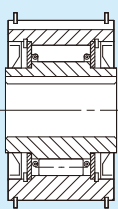

MDEU-2GD

### Typical installation

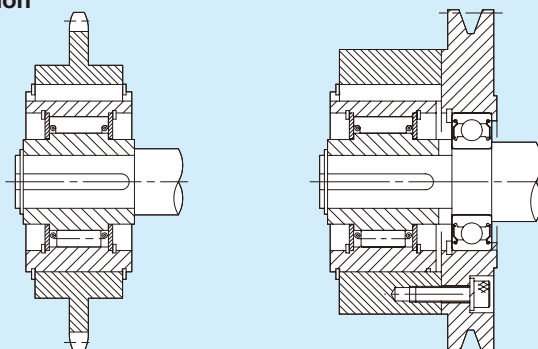

# MX SERIES CAM CLUTCH

## MODELS MX 22 TO MX 70

### For Indexing Applications

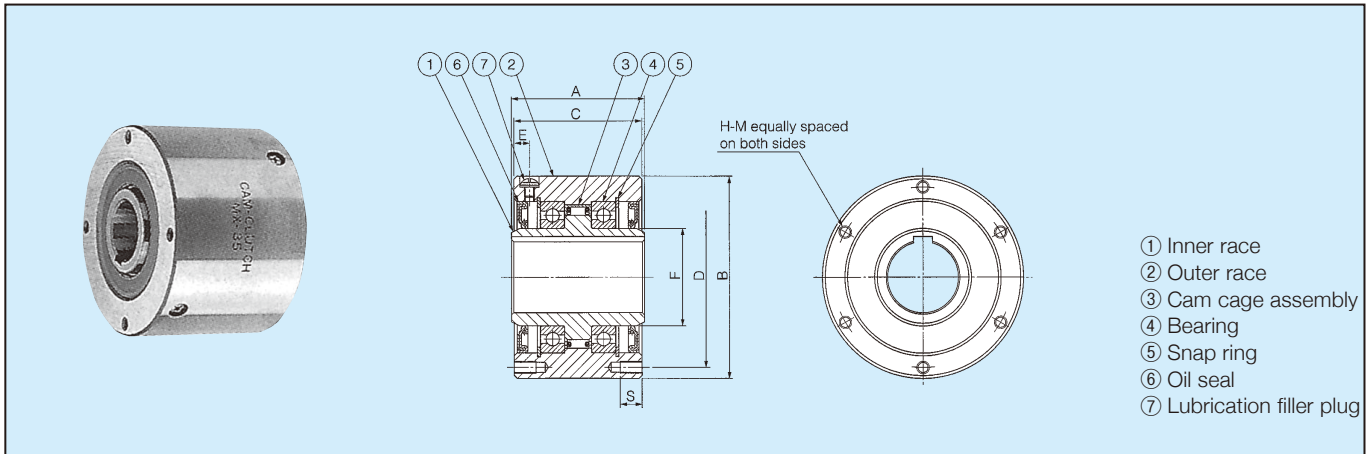

### Dimensions and Capacities

Dimensions in mm

Model	Torque Capacity (N·m)	Max. Indexing (cycle/min)	Bore Size		A	B (h7)	C	PCD D	E	F	S	H-M No. of Tapped Holes × Size × Pitch	Lubrication Filler Plug Size × Pitch	Inertia Inner Race (kg·m <sup>2</sup> )	Drag Torque (N·m)	Oil (ml)	Weight (kg)
			Dia. (H7)	Keyway													
MX22	78.4	1200	22	6×2.8	80	95	77	80	12	35	16	4×M 8×P1.25	M6×P1.0	0.000150	0.470	80	3.3
MX35	235	1200	35	10×3.3	90	125	87	110	12	50	16	4×M 8×P1.25	M6×P1.0	0.000625	1.36	110	6.4
MX50	441	1200	50	14×3.8	100	155	97	140	14	70	16	6×M 8×P1.25	M8×P1.25	0.00275	2.68	190	10.6
MX70	784	1200	70	20×4.9	127	200	124	180	15	100	20	6×M10×P1.5	M8×P1.25	0.0130	5.15	340	21.3

**Note:** Above torque is based on  $10^8$  times load cycles.

### Installation and Usage

1. For installation, insert the clutch into the hub bore of a pulley, a gear, or a torque arm and screw the bolts (high tension) into the tapped holes in the end face of the clutch. See illustration on the right.
2. A press fit is required for MX Series clutches for indexing applications, but do not exceed 0.025 mm when press fitting.
3. Adjust the side of the key to fit the keyway tightly, but allow a clearance between the top of key and keyway.
4. When mounting the clutch on a shaft, apply pressure to the clutch inner race end, but never to the outer race.
5. Proper selection of the Cam Clutch provides accurate indexing performance. A braking device and a backstopping device may also be required for more accurate performance.
6. The tolerance of the hub bore should be H6 or H7.

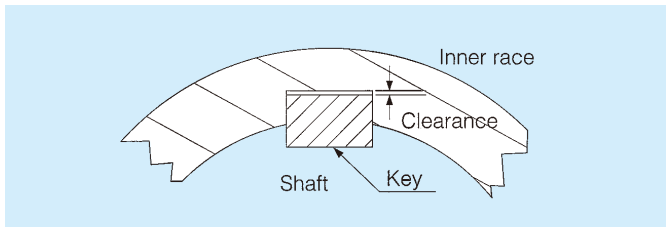

### Typical installation MX Series

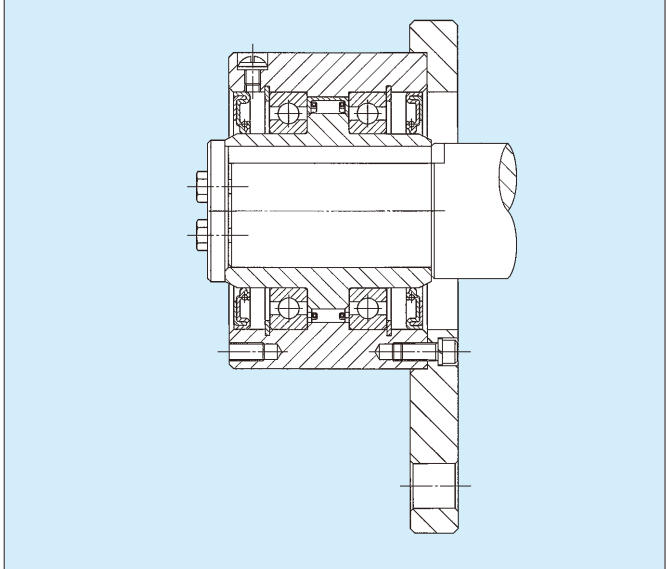

- See "Information for Selection" on page 77.
- See "Lubrication and Maintenance" on page 79.

# MI-S SERIES CAM CLUTCH

## MODELS MI 20S AND MI 30S

For Special Applications

### Features:

1. Specially treated cams are used to achieve better wear resistance.
2. Feeding drive for bag-making machines or coiling machines.

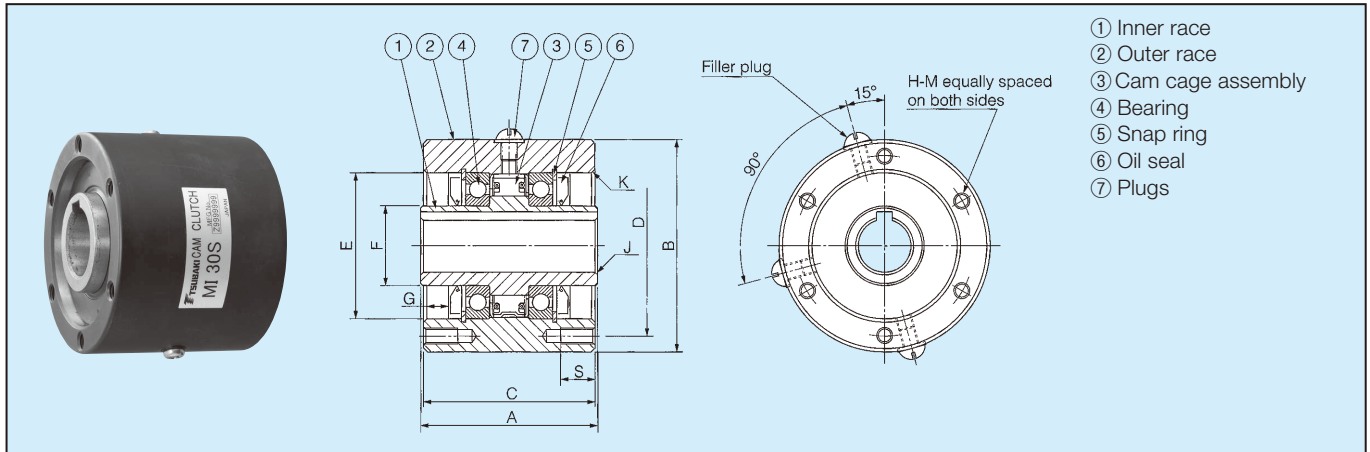

### Dimensions and Capacities

Dimensions in mm

Model	Torque Capacity (N·m)	Max. Indexing (cycle/min)	Drag Torque (N·m)	Bore Size			A	C	B	F	E (M6)	G	K	PCD D	S	H-M No. of Tapped Holes x Size x Pitch	Oil (ml)	Weight (kg)
				Dia. (H7)	Keyway	Chamfer J												
MI 20S	43.1	300	0.29	20	6×2.8	1.0	67	65	80	30	55	8.0	1.0	68	13	6-M6×P1.0	45	1.9
MI 30S	196	300	1.08	30	10×3.3	1.0	82	80	100	45	75	5.5	1.0	88	16	6-M6×P1.25	100	4.0

### Installation and Usage

1. When mounting sprockets or gears to the outer race, use the outer race inner dimension (dimension E) to make a centering flange on the sprocket or gear. Then attach firmly with bolts of tensile strength 10.9 or greater to the tapped holes in the outer race. Recommended tolerance between mounted gear and centering flange is f7.
2. The recommended shaft tolerance is h6 or h7.
3. Always use a parallel key, and do not use a tapered key. A parallel key meeting ISO R773 (DIN 6885.1) is recommended. Make sure that there is no lateral play between the key and keyways. Install an end plate on the face of the inner race
4. When inserting the shaft, apply pressure only to the face of the inner race only.
5. See "Lubrication and Maintenance" on page 79.

# BS SERIES CAM CLUTCH

## For Reverse Rotation Prevention on Conveyors

The BS series Cam Clutches are intended for applications where reverse rotation of the slow speed conveyor head shaft is to be prevented (backstopping).

### MODELS BS30 TO BS135

#### BS30 to 135

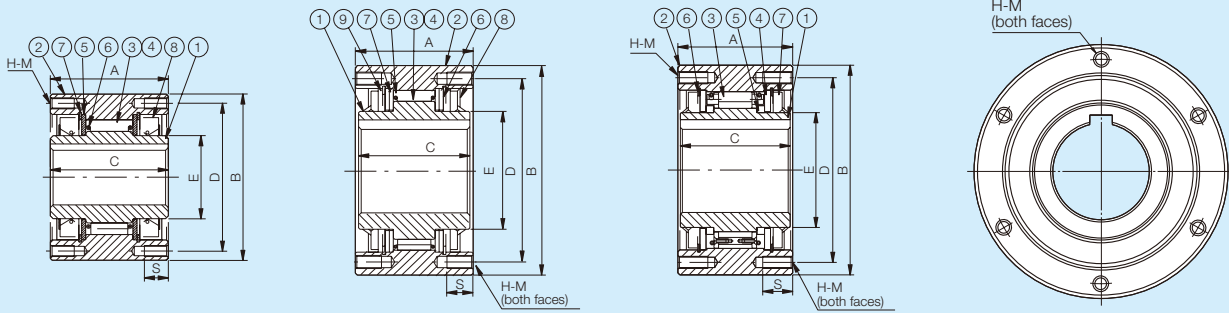

#### BS30 to BS50

- ① Inner race
- ② Outer race
- ③ Cam
- ④ Roller
- ⑤ Plate
- ⑥ Spring
- ⑦ Snap ring
- ⑧ Oil seal

#### BS65 to BS75

- ① Inner race
- ② Outer race
- ③ Cam
- ④ Roller
- ⑤ Spring
- ⑥ Plate
- ⑦ Thrust metal
- ⑧ Oil seal
- ⑨ Snap ring

#### BS85 to BS135

- ① Inner race
- ② Outer race
- ③ Cam cage
- ④ Plate
- ⑤ Thrust metal
- ⑥ Snap ring
- ⑦ Oil seal

#### Chamfer of the bore end faces

Shaft Diameter	Chamfer
Under 50 mm	1.5 C
50 to 125 mm	2.0 C
125 to 285 mm	3.0 C

### MODELS BS250 TO BS450

#### BS250 to 450

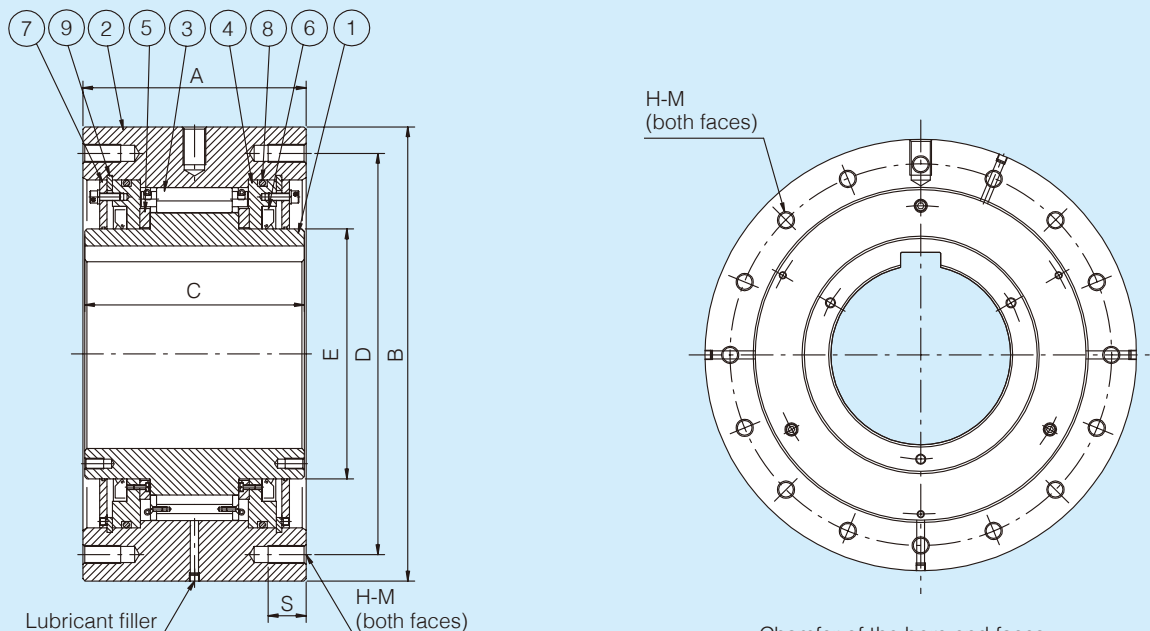

- ① Inner race
- ② Outer race
- ③ Cam cage
- ④ Seal supporter
- ⑤ Thrust metal

- ⑥ Oil seal
- ⑦ Grease fitting
- ⑧ O-ring
- ⑨ Snap ring

#### Chamfer of the bore end faces

Shaft Diameter	Chamfer
125 to 285 mm	3.0 C
Over 285 mm	5.0 C

# BS SERIES CAM CLUTCH

## Dimensions and Capacities

Dimensions in mm

Model	Torque Capacity (N-m)	Max. Overrunning (r/min) Inner Race	Drag Torque (N-m)	A	B	C	PCD D	E	S	H-M Size×Pitch × No. of Tapped Holes	Grease Filler Hole (Size)	Q'ty of Grease (kg)
BS 30	294	350	0.58	64	90	64	80	45	13	M 6×P1.0×4	—	—
BS 50	784	300	0.98	67	125	67	110	70	16	M 8×P1.25×4	—	—
BS 65	1570	340	3.92	90	160	85	140	90	20	M10×P1.5×6	—	—
BS 75	2450	300	5.88	90	170	85	150	100	20	M10×P1.5×6	—	—
BS 85	5880	300	7.84	115	210	110	185	115	30	M12×P1.75×6	—	—
BS 95	7840	250	9.8	115	230	110	200	130	30	M14×P2.0×6	—	—
BS 110	10800	250	14.7	115	270	110	220	150	30	M16×P2.0×6	—	—
BS 135	15700	200	19.6	135	320	130	280	180	30	M16×P2.0×8	—	—
BS 160	24500	100	34.3	135	360	130	315	220	40	M20×P2.5×10	PT 1/4	0.12
BS 200	37200	100	44.1	150	430	145	380	265	40	M22×P2.5×8	PT 1/4	0.14
BS 220	49000	80	73.5	235	500	230	420	290	40	M20×P2.5×16	PT 1/4	0.8
BS 250	88200	50	93.1	295	600	290	530	330	50	M24×P3.0×16	PT 1/4	1.1
BS 270	123000	50	98	295	650	290	575	370	50	M24×P3.0×16	PT 1/4	1.2
BS 300	176000	50	108	295	780	290	690	470	60	M30×P3.5×16	PT 1/4	1.3
BS 335	265000	50	137	305	850	320	750	495	70	M36×P4.0×16	PT 1/4	1.4
BS 350	314000	50	157	320	930	360	815	535	70	M36×P4.0×16	PT 1/4	1.5
BS 425	510000	50	216	440	1030	450	940	635	70	M36×P4.0×18	—	Oil 6000ml
BS 450	686000	50	245	450	1090	480	990	645	80	M42×P4.5×18	—	Oil 7000ml

## Bore Keyway, Weight

New JIS Keyway JISB1301-1996 ISO R773	Old JIS Keyway JISB1301-1959	Bore Diameter Range (mm)	Weight at Minimum Bore (kg)	Weight at Maximum Bore (kg)
<b>BS 30-30J</b>	BS 30-30E	20 to 30	2.3	2.1
<b>BS 50-45J</b>	BS 50-45E	30 to 50	4.7	4.0
<b>BS 50-50J</b>	BS 50-50E			
<b>BS 65-40J</b>	BS 65-40E	40 to 65	13.0	11.5
<b>BS 65-45J</b>	BS 65-45E			
<b>BS 65-50J</b>	BS 65-50E			
<b>BS 65-55J</b>	BS 65-55E			
<b>BS 65-60J</b>	BS 65-60E			
<b>BS 65-65J</b>	BS 65-65E			
<b>BS 75-60J</b>	BS 75-60E	50 to 75	14.7	13.1
<b>BS 75-65J</b>	BS 75-65E			
<b>BS 75-70J</b>	BS 75-70E			
<b>BS 75-75J</b>	BS 75-75E			
<b>BS 85-70J</b>	BS 85-70E	60 to 85	27.2	24.7
<b>BS 85-75J</b>	BS 85-75E			
<b>BS 85-80J</b>	BS 85-80E			
<b>BS 85-85J</b>	BS 85-85E			
<b>BS 95-80J</b>	BS 95-80E			
<b>BS 95-85J</b>	BS 95-85E	70 to 95	32.2	29.4
<b>BS 95-90J</b>	BS 95-90E			
<b>BS 95-95J</b>	BS 95-95E			
<b>BS 110-85J</b>	BS 110-85E	80 to 110	38.6	34.2
<b>BS 110-95J</b>	BS 110-95E			
<b>BS 110-100J</b>	BS 110-100E			
<b>BS 110-105J</b>	BS 110-105E			
<b>BS 110-110J</b>	BS 110-110E			
BS 135	BS 135	90 to 135	76.1	68.0
BS 160	BS 160	100 to 160	98.1	85.6
BS 200	BS 200	100 to 200	167	140
BS 220	BS 220	150 to 220	301	264
BS 250	BS 250	175 to 250	580	523
BS 270	BS 270	200 to 270	620	562
BS 300	BS 300	230 to 300	952	885
BS 335	BS 335	250 to 335	1140	1040
BS 350	BS 350	250 to 350	1600	1470
BS 425	BS 425	325 to 425	2450	2240
BS 450	BS 450	350 to 450	2820	2580

## Format

### BS85 - 85 J

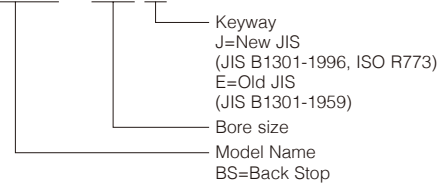

### BS250 - 250J

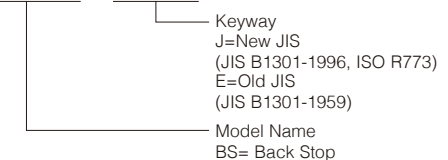

- Notes:**
- The tolerance of Stock Finished Bore is H7.
  - Items highlighted in bold type are stock items, the others are built to order.
  - BS Cam Clutch can be bored according to your specification. Specify the bore diameter with tolerance and keyway dimensions. Please be sure to specify.
  - As for Torque Arm and Safety Cover, please refer to pages 50 and 51.

## BS-F SERIES CAM CLUTCH

The BS series Cam Clutches are intended for applications where reverse rotation of the slow speed conveyor head shaft is to be prevented (backstopping).

### MODELS BS85F TO BS465F

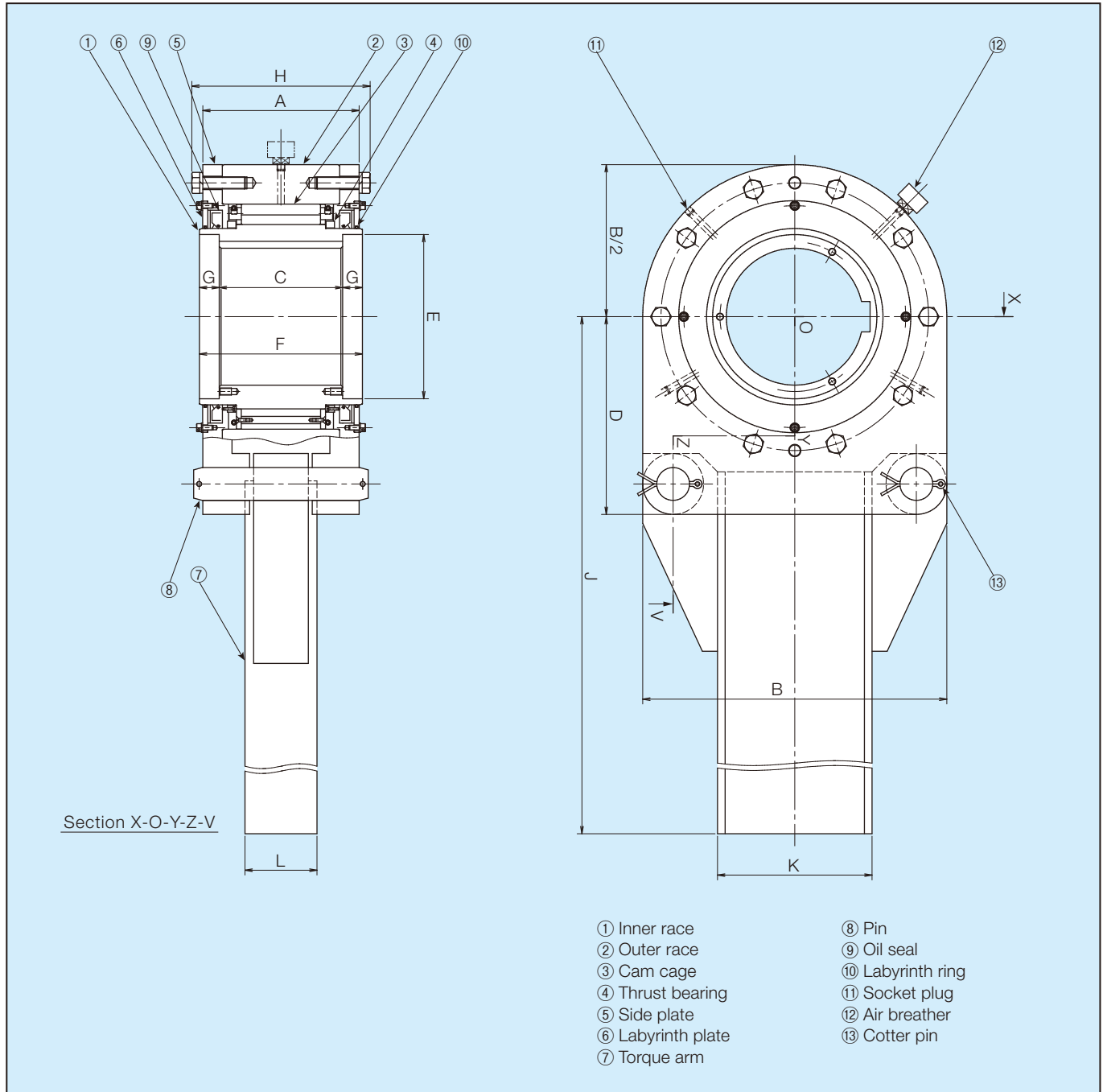

# BS-F SERIES CAM CLUTCH

## Capacities

Size	Torque Capacity (N·m)	<sup>1</sup> Max. Overrunning (r/min) Inner Race	Bore range (mm)		Drag Torque (N·m)	Mass (kg)				Amount of grease (kg)
			Min.	Max.		Within Torque arm		Without Torque arm		
						Min.bore	Max.bore	Min.bore	Max.bore	
BS85F	6760	300	60	85	8	44	41	31	28	0.065
BS95F	8940	300	70	95	10	52	49	37	34	0.075
BS115F	16300	300	80	115	15	83	77	59	53	0.105
BS140F	24400	300	90	140	20	116	106	84	74	0.15
BS165F	44100	300	100	165	34	169	154	118	103	0.16
BS200F	61700	180	100	200	44	250	222	185	157	0.19
BS225F	102000	150	150	225	74	492	442	386	336	1.3
BS250F	147000	135	175	250	93	696	639	556	499	1.4
BS270F	192000	125	200	270	98	852	791	692	631	1.6
BS300F	345000	115	230	300	108	1340	1270	1050	973	1.8
BS360F	489000	100	250	360	157	1930	1810	1580	1460	1.9
BS425F	735000	85	325	425	216	3130	2940	2610	2420	3.5
BS465F	980000	80	350	465	245	3740	3480	3160	2900	4.4

<sup>1</sup> Please refer to the Graph 1 (Page 45) when ambient operating temperature is from 40°C to 65°C.

## Dimensions

All dimensions are in mm.

Size	A	B	C	D	E	F	G	H	J	K	L
BS85F	107	210	105	151	106	120	7.5	127	813	76	64
BS95F	107	230	112	161	120	120	4	127	914	100	75
BS115F	127	270	127	181	142	135	4	149	1270	100	75
BS140F	127	320	134	207.5	170	142	4	151	1422	125	75
BS165F	141	360	134	242.5	209	142	4	169	1676	180	100
BS200F	150	430	142	284	251	150	4	178	1829	200	100
BS225F	257	500	203	325	270	268	32.5	293	1981	250	125
BS250F	247	600	229	385	300	272	21.5	283	2083	300	150
BS270F	267	650	254	415	344	280	13	303	2235	300	150
BS300F	278	780	273	490	430	286	6.5	320	2388	350	150
BS360F	292	930	278	585	490	286	4	345	2540	400	150
BS425F	380	1030	396	645	600	404	4	433	2743	450	175
BS465F	410	1090	417	690	600	432	7.5	474	3048	600	190

## Model name

### BS300F - 280JM

Model Name  
BS : Back Stop  
300 : Size  
F : F series

Bore size in mm  
280 : 280mm H7

Keyway  
JIS B1301-1996, ISO R773

<sup>2</sup> Torque arm type  
M : Metric I-Beam  
A : Imperial I-Beam  
(Made to Order)

<sup>2</sup> This I-Beam is made specifically for BACKSTOP and does not necessarily conform to ANSI or JIS standards.

# BS & BS-F SERIES CAM CLUTCH

## Installation and Usage

1. Recommended shaft tolerance is h7 or h8.
2. Before installation on to the shaft, check the operational rotation direction of the shaft and make sure that it is the same as the overrunning direction of the BS/BS-F Cam Clutch.
3. Securely install the torque arm to the BS Cam Clutch using bolts with a strength class of 10.9 grade or higher.
4. Make sure the surface of the torque arm that contacts the end face of the outer race is flat and free of dust in order to get enough frictional force.
5. Apply pressure only on the end face of the inner race when inserting the BS/BS-F Cam Clutch on to the shaft. Do not hit the inner race directly with a hammer or apply pressure on the outer race, oil seal, or grease fitting.
6. Always use a parallel key for installation onto the shaft and then fix the BS/BS-F Cam Clutch to the shaft with the end plate. Never use a tapered key, otherwise the Cam Clutch will be damaged.
7. When installing models BS85F or BS160 and up (grease lubrication types), place one of the four socket plugs underneath the Cam Clutch. This will allow for easy drainage of the grease during maintenance.
8. The end tip of the torque arm will swing to some extent while the conveyor is operating. Support the torque arm end tip only in the direction of rotation, but be sure to allow it a certain amount of free movement axially. (Refer to installation diagram.) The Cam Clutch will sustain damage if the torque arm end tip is fixed securely.
9. A single torque arm is sufficient for models from BS30 to BS220. One torque arm on each side is required for models from BS220 to BS450, and to stop the rotation by both torque arms so that the reverse load operates on the torque arms evenly. It is recommended to use the standardized torque arm and safety cover for the BS Cam Clutch.
10. In case the ambient temperature rises 40°C and up, it is recommended to set shield or roof and avoid direct sunlight in order to extend the life span of BS/BS-F Cam Clutch.  
(BS-F Series)  
Please refer to the Graph1 when ambient operating temperature of BS-F is from 40°C~65°C.
11. Refer to page 79 for "Lubrication and Maintenance".

**Graph1**

【BS-F】 Relation between overrunning speed and ambient operating temperature

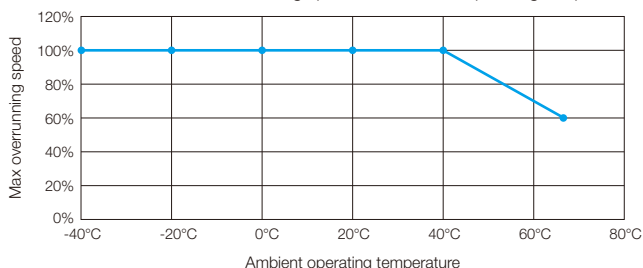

## INSTALLATION AND USAGE

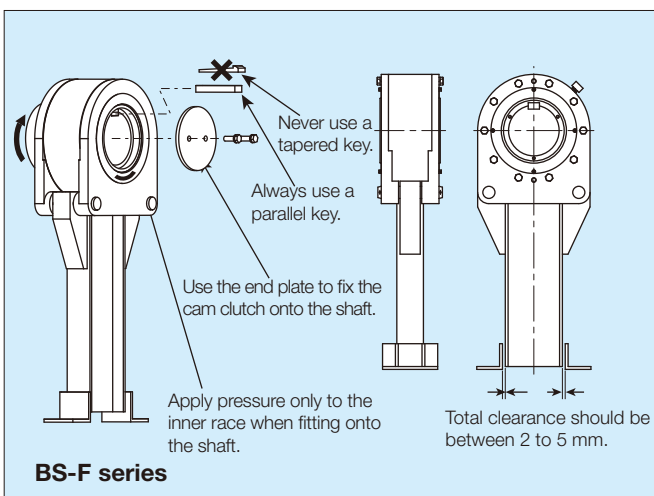
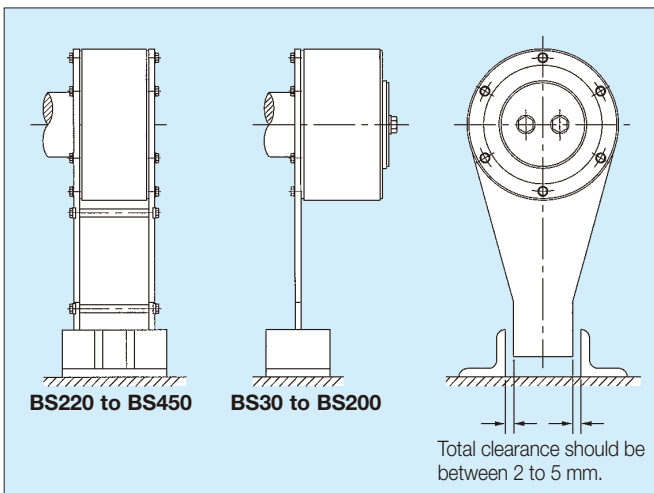
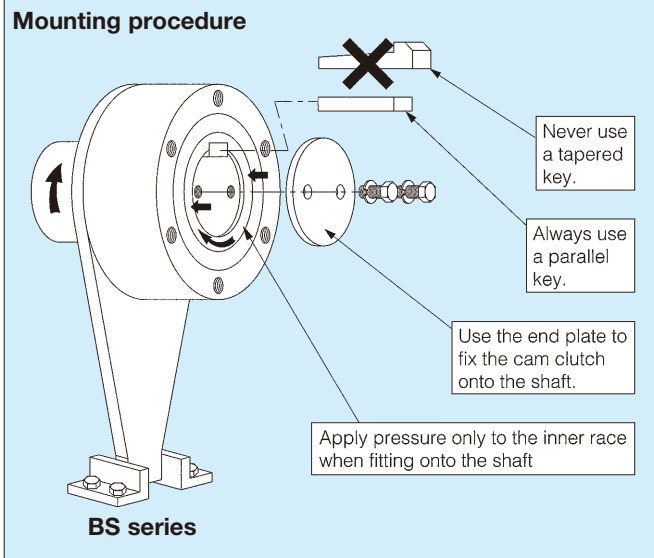

# BS-R SERIES CAM CLUTCH

The BS-R series offer easy lubrication maintenance.

## MODELS BS65R TO BS135R

### Oil Reservoir Types

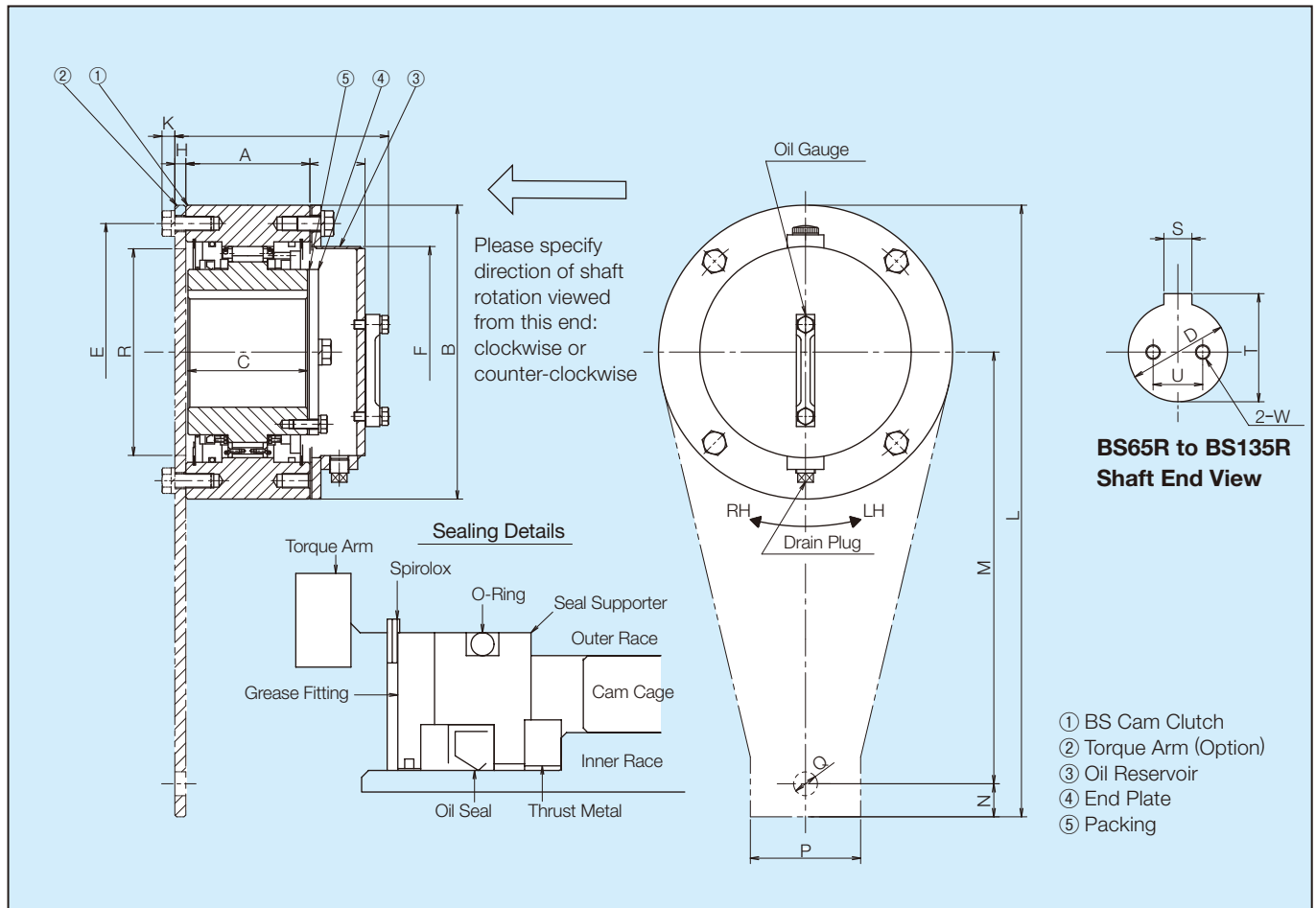

When ordering the Oil Reservoir Type, please specify using the list below.

D	Bore Dia. (mm)	W	Size of Tapped Holes
S	Keyway Width (mm)	a	Angle: Relation between Center of Keyway and Tapped Holes (degree)
T	Keyway Height (mm)	RH (CW.) LH (CCW.)	Direction of Shaft Rotation
U	Distance between Tapped Holes (mm)		

### Dimensions and Capacities

Dimensions in mm

Model	Torque Capacity (N-m)	Bore Diameter Range	Max. Overrunning (r/m) Inner Race	A	B	C	PCD E	F	G	H	K	L	M	N	P	Q	R
BS 65R	1570	40 to 65	200	90	160	85	140	115	50	6	9.5	306	210	16	50	13.5	90
BS 75R	2450	50 to 75	180	90	170	85	150	125	50	6	9.5	354	250	19	65	16.5	100
BS 85R	5880	60 to 85	180	115	210	110	185	140	60	9	11	434	300	29	95	20.5	115
BS 95R	7840	70 to 95	170	115	230	110	200	160	60	9	12.5	497	350	32	105	20.5	130
BS 110R	10800	80 to 110	170	115	270	110	220	180	60	12	14	560	385	40	110	26	140
BS 135R	15700	90 to 135	120	135	320	130	280	230	60	12	14	666	470	36	120	26	180

Model	Mounting Bolt Size-Quantity		Stop Plate Bolt Size-Quantity	Oil (ml)	Weight at Minimum Bore (kg)	Weight at Maximum Bore (kg)
	Torque Arm Side	Oil Reserver Side				
BS 65R	M10×25 ℓ-6	M10×20 ℓ-3	M 6×20ℓ-3+2	250	15.8	14.3
BS 75R	M10×25 ℓ-6	M10×20 ℓ-3	M 6×20ℓ-3+2	300	18.1	16.5
BS 85R	M12×30 ℓ-6	M12×25 ℓ-3	M 6×25ℓ-3+2	450	33.9	31.4
BS 95R	M14×35 ℓ-6	M14×30 ℓ-3	M 6×25ℓ-3+2	600	40.9	38.1
BS 110R	M16×40 ℓ-6	M16×35 ℓ-3	M 8×25ℓ-3+2	750	51.3	46.9
BS 135R	M16×35 ℓ-8	M16×35 ℓ-4	M10×30ℓ-3+2	1300	94.3	86.2

**Note:** Please refer to notes on page 47 when ordering.

## MODELS BS160R TO BS200R

### Oil Reservoir Types

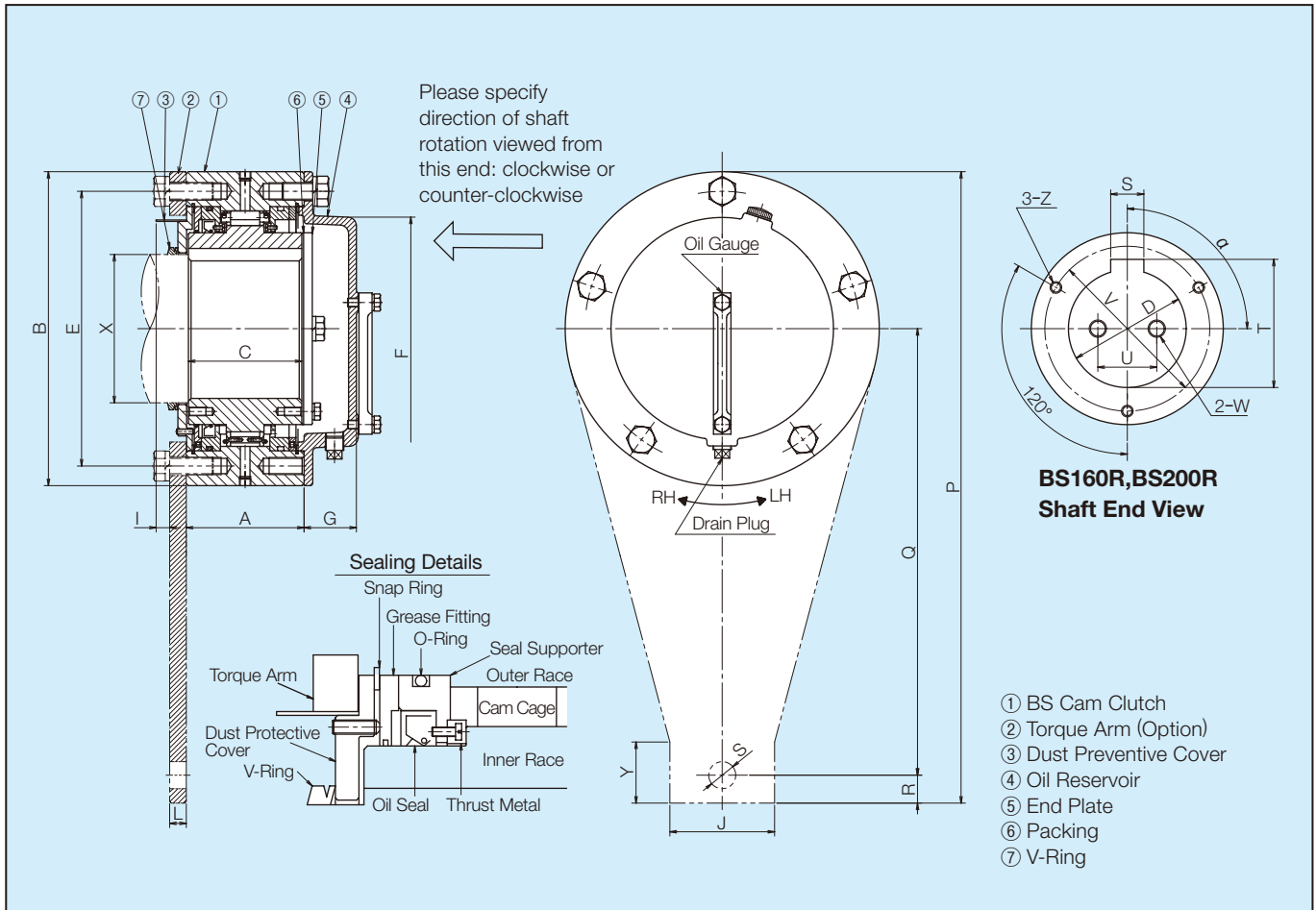

When ordering the Oil Reservoir Type, please specify using the list below.

D	Bore Dia. (mm)	W	Size of Tapped Holes
S	Keyway Width (mm)	a	Angle: Relation between Center of Keyway and Tapped Holes (degree)
T	Keyway Height (mm)	X	Dia. of Shaft Shoulder (mm)
U	Distance between Tapped Holes (mm)	RH (CW.) LH (CCW.)	Direction of Shaft Rotation

### Dimensions and Capacities

Dimensions in mm

Model	Torque Capacity (N·m)	Bore Diameter Range	Max. Overrunning (r/m) Inner Race	A	B	C	PCD E	F	G	L	I	J	R	P	Q	S	V	Y	Z
BS 160R	24500	100 to 160	100	135	360	130	315	255	60	19	16	120	32	792	580	31	190	65	M10
BS 200R	37200	100 to 200	100	150	430	145	380	310	60	19	21	130	43	838	623	41	235	70	M12

Model	Mounting Bolt Size-Quantity		Oil (ml)	Weight at Minimum Bore (kg)	Weight at Maximum Bore (kg)
	Torque Arm Side	Oil Reserver Side			
BS 160R	M20×55ℓ-10	M20×40ℓ-5	1300	108	95
BS 200R	M22×60ℓ-8	M22×40ℓ-4	1900	182	155

**Notes:** 1. BS-R Cam Clutch can be bored according to your specifications, but please specify the bore diameter with tolerance and keyway dimensions.  
 2. Torque Arms are optional. The arm shown above is only for your reference. If necessary, please specify it on your order.

## MODELS BS220R TO BS450R

### Oil Reservoir Types

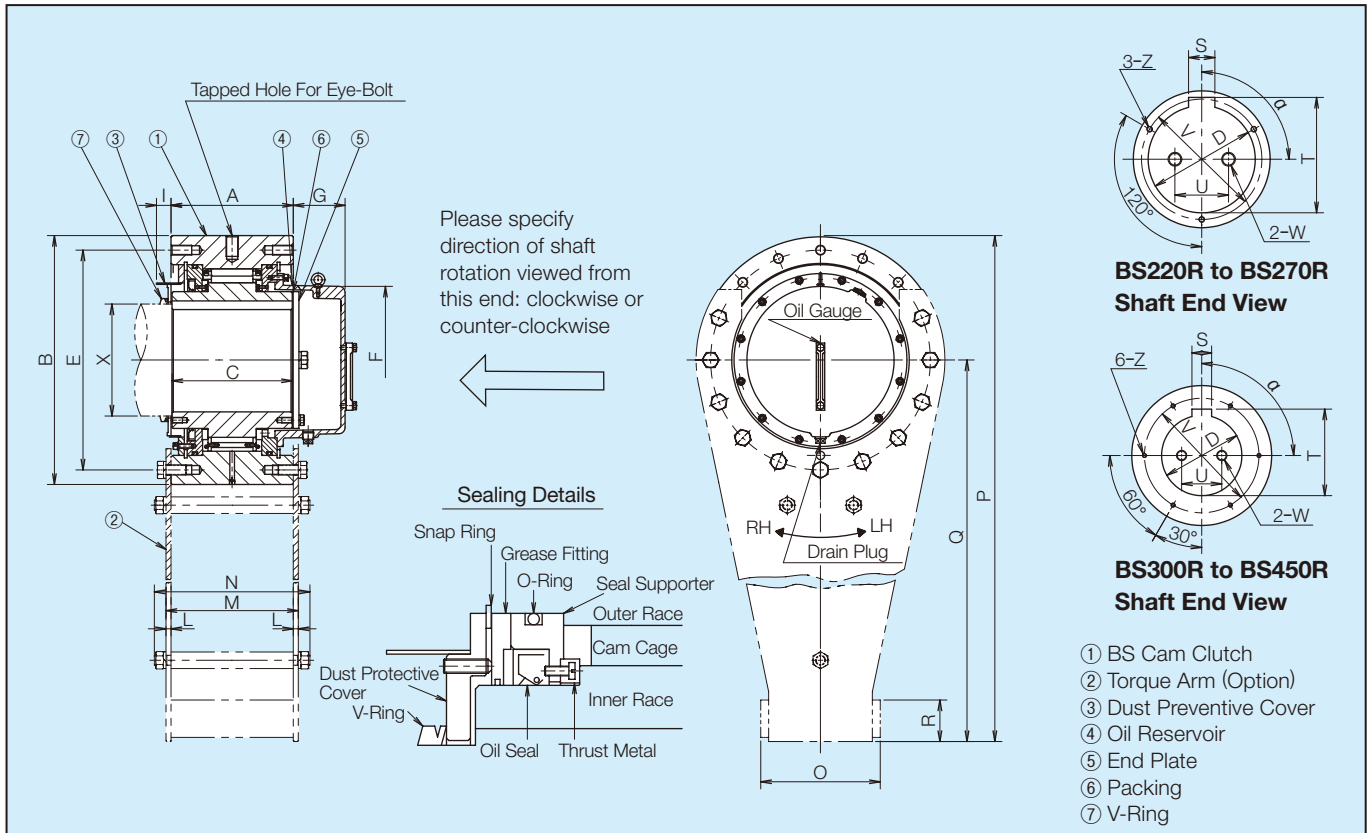

When ordering the Oil Reservoir Type, please specify using the list below.

D	Bore Dia. (mm)	W	Size of Tapped Holes
S	Keyway Width (mm)	a	Angle: Relation between Center of Keyway and Tapped Holes (degree)
T	Keyway Height (mm)	X	Dia. of Shaft Shoulder (mm)
U	Distance between Tapped Holes (mm)	RH (CW.) LH (CCW.)	Direction of Shaft Rotation

### Dimensions and Capacities

Dimensions in mm

Model	Torque Capacity (N·m)	Bore Diameter Range	Max. Overrunning (r/m) Inner Race	A	B	C	PCD E	F	G	I	L	M	N	O	P	Q	R	V	Z
BS 220R	49000	150 to 220	80	235	500	230	420	296	95	35	12	259	311	238	1070	820	80	255	M12
BS 250R	88200	175 to 250	50	295	600	290	530	355	125	35	12	319	375	288	1300	1000	100	290	M14
BS 270R	123000	200 to 270	50	295	650	290	575	395	130	40	12	319	375	298	1425	1100	110	320	M14
BS 300R	176000	230 to 300	50	295	780	290	690	495	130	45	19	333	396	356	1690	1300	135	385	M14
BS 335R	265000	250 to 335	50	305	850	320	750	525	135	60	19	343	405	386	1925	1500	135	415	M16
BS 350R	314000	250 to 350	50	320	930	360	815	565	135	71	19	358	430	414	2065	1600	135	442	M16
BS 425R	510000	325 to 425	50	440	1030	450	940	680	170	70	22	484	570	474	2315	1800	165	530	M20
BS 450R	686000	350 to 450	50	450	1090	480	990	690	180	80	22	494	580	526	2545	2000	165	550	M20

Model	Mounting Bolt Size-Quantity	Oil (ml)	Weight at Minimum Bore (kg)	Weight at Maximum Bore (kg)
BS 220R	M20 × 550-22	3400	347	310
BS 250R	M24 × 550-22	8200	637	580
BS 270R	M24 × 550-22	10000	660	602
BS 300R	M30 × 700-22	15000	1050	983
BS 335R	M36 × 850-22	16000	1210	1120
BS 350R	M36 × 850-22	18000	1710	1580
BS 425R	M36 × 850-26	32000	1580	2370
BS 450R	M42 × 1000-26	35000	2930	2690

Note: Please refer to notes on page 47 when ordering.

## ■ BS-R INSTALLATION PROCEDURES

### Pre-Installation

1. The oil reservoir and the end plate are fixed to the BS Cam Clutch temporarily when packed to prevent dust from entering during transportation. Carefully remove them from the clutch and prevent the dust from penetrating into the clutch.
2. For models from BS160R to BS450R, Apply the grease between the space where the dust cover fits and the seal supporter. (The grease prevents the dust from entering.)
3. Attach the dust cover to the Cam Clutch.
4. Check whether the rotational direction of the conveyor shaft corresponds to that of the BS Cam Clutch viewed from the oil reservoir (the overrunning direction is shown as an arrow on the end face of the inner race)
5. Securely install the torque arm to the BS Cam Clutch using bolts with a strength class of 10.9 grade or higher. Make sure the surface of the torque arm which contacts the end face of the outer race is flat and free of dust, to ensure enough frictional force is achieved.

### Installation

1. Pre-insert the V-ring into the conveyor shaft in the correct direction.
2. Securely install the BS Cam Clutch onto the shaft. Apply the pressure only on the end face of the inner race when inserting the BS Cam Clutch onto the shaft. Do not hit the inner race directly with a hammer or apply pressure on the outer race. (Refer to page 45 for Installation and Usage)
3. Apply the sealant supplied, to the end face of the inner race and packing, and fix the BS Cam Clutch unit to the conveyor shaft with the end plate. At the same time, use the seal washer on each bolt to prevent oil leakage.
4. After cleaning the inside of the oil reservoir, apply the sealant on the mating face of the oil reservoir. Place the oil level gauge vertically (red line is bottom, and blue is top), for models from BS65R to BS200R; install the oil reservoir to the end face of the outer race with the bolts, while for models BS220R and above, install the oil reservoir to the seal supporter using the bolts. Carefully prevent dust from penetrating the Cam Clutch or oil reservoir.
5. Press the pre-inserted V-ring entirely so that the face of the dust cover contacts closely.
6. In case the ambient temperature rises 40°C and above, it is recommended to set shield or roof and avoid direct sunlight in order to extend the life span of Cam Clutch.

## ■ INSTALLATION PROCEDURE OF OIL RESERVOIR TYPE BS CAM CLUTCH

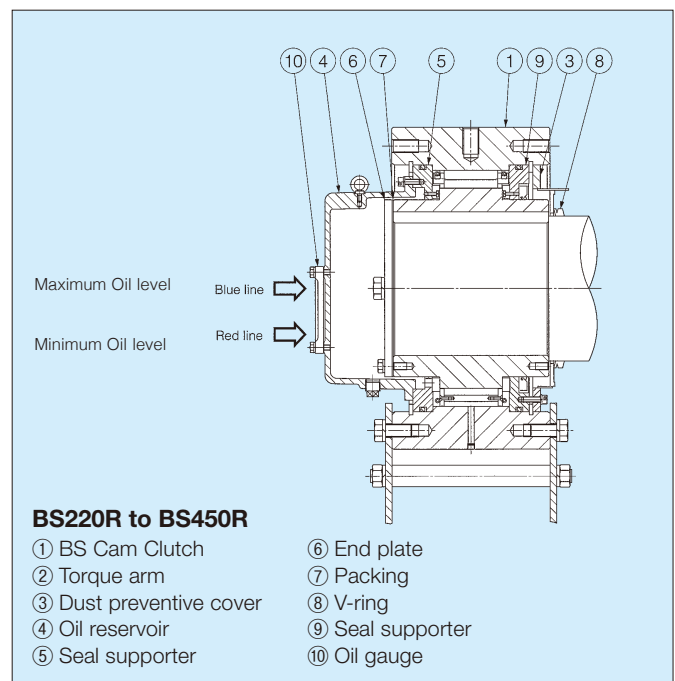
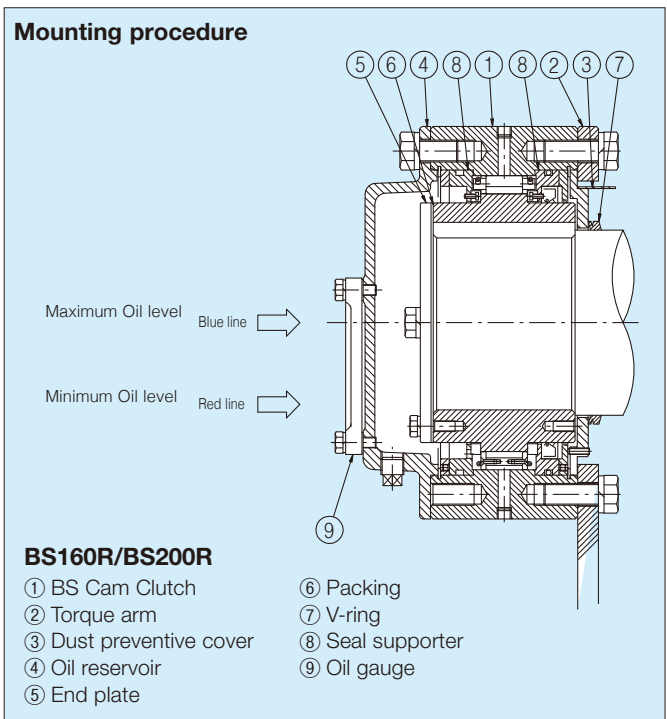

# TORQUE ARM FOR BS SERIES

## TORQUE ARM (OPTION)

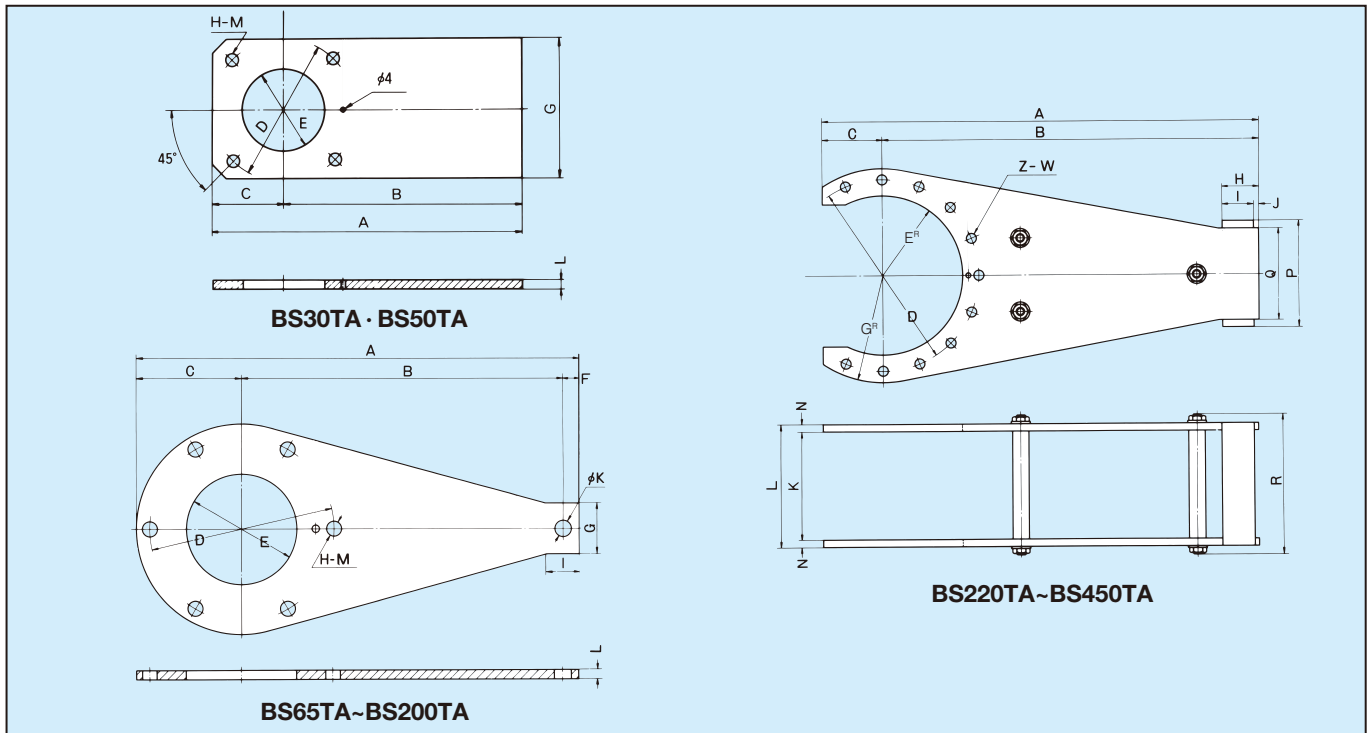

### Dimensions

#### BS30TA~BS200TA (Single Torque Arm)

Dimensions in mm

Torque Arm No.	A	B	C	D	E	F	G	I	K	L	H-M	Weight(kg)
<b>BS 30TA</b>	168	130	38	80	55	—	75	—	—	6	4- 6.6	0.5
<b>BS 50TA</b>	230	180	50	110	80	—	100	—	—	6	4- 9	0.8
<b>BS 65TA</b>	306	210	80	140	90	16	50	30	13.5	6	6-11	1.2
<b>BS 75TA</b>	354	250	85	150	100	19	65	35	16.5	6	6-11	1.6
<b>BS 85TA</b>	434	300	105	185	115	29	95	45	20.5	9	6-14	3.8
<b>BS 95TA</b>	497	350	115	200	130	32	105	55	20.5	9	6-16	4.7
<b>BS 110TA</b>	560	385	135	220	140	40	110	60	26	12	6-18	8.3
<b>BS 135TA</b>	666	470	160	280	180	36	120	65	26	12	8-18	11.1
<b>BS 160TA</b>	792	580	180	315	260	32	120	65	31	19	10-22	20.0
<b>BS 200TA</b>	838	580	215	380	310	43	130	70	41	19	8-24	23.8

#### BS220TA~BS450TA (Double Torque Arm)

Dimensions in mm

Torque Arm No.	A	B	C	D	E	G	H	I	J	K	L	N	P	Q	R	Z-W	Weight(kg)
BS 220TA	950	820	130	420	176	235	80	70	10	235	259	12	238	200	311	11-22	59
BS 250TA	1170	1000	170	530	214	300	100	90	10	295	319	12	288	250	375	11-26	96
BS 270TA	1270	1100	170	575	235	325	110	100	10	295	319	12	298	260	375	11-26	110
BS 300TA	1480	1300	180	690	285	390	135	120	15	295	333	19	356	300	396	11-32	240
BS 335TA	1730	1500	230	750	307	425	135	120	15	305	343	19	386	330	405	11-39	270
BS 350TA	1850	1600	250	815	328	465	135	120	15	320	358	19	414	350	430	11-39	330
BS 425TA	2110	1800	310	940	380	515	165	150	15	440	484	22	474	410	570	13-39	480
BS 450TA	2320	2000	320	990	400	545	165	150	15	450	494	22	526	450	580	13-45	560

- Notes:** 1. Items highlighted in bold type are stock, the others are built to order.  
2. Mounting bolts and spring washers for installation are attached.

### Recommend End Plate Dimension Table

Dimensions in mm

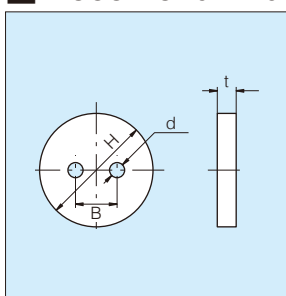

Model	H	t	d	B	Mounting Bolts Size
BS 30	45	4.5	6	10	M5
BS 50	70	4.5	7	20	M6
BS 65	90	6	9.5	25	M8
BS 75	100	6	9.5	25	M8
BS 85	115	9	9.5	25	M8
BS 95	125	9	11.5	45	M10
BS 110	140	9	11.5	45	M10
BS 135	175	10	11.5	45	M10
BS 160	200	10	14.5	60	M12

Model	H	t	d	B	Mounting Bolts Size
BS 200	240	10	14.5	60	M12
BS 220	280	14	14.5	60	M12
BS 250	310	14	18.5	100	M16
BS 270	330	14	18.5	100	M16
BS 300	360	14	18.5	100	M16
BS 335	380	14	18.5	100	M16
BS 350	410	14	18.5	100	M16
BS 425	460	18	22.5	150	M20
BS 450	510	18	22.5	150	M20

**Note:** This dimension is only for reference when manufacturing it at customer's side depending on your need.

## SAFETY COVER FOR BS SERIES

1. This safety cover is for the BS Cam Clutch.
2. Safety cover for the protection of the rotating portion of the Cam Clutch and the prevention of hands, etc. getting caught up in the Cam Clutch.



Contents delivered

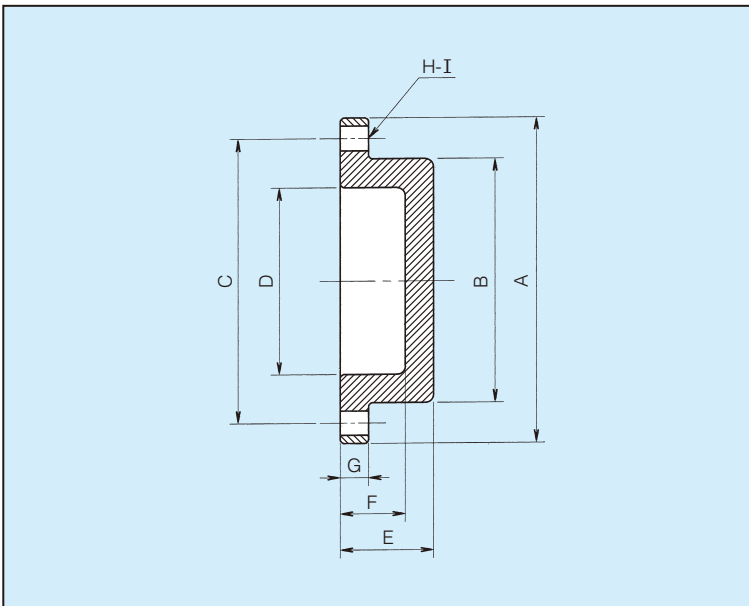

### Dimensions

Dimensions in mm

Model	A	B	C	D	E	F	G	H-I	Mounting Bolts Size-Quantity	Weight (kg)
BS 30-SC	90	60	80	48	24	18	7	4- 6.6	M6 ×16 $\varnothing$ -4	0.5
BS 50-SC	125	85	110	73	27	21	7	4- 9.0	M8 ×20 $\varnothing$ -4	0.9
BS 65-SC	160	110	140	96	33	26	8	6-11.0	M10×25 $\varnothing$ -6	1.7
BS 75-SC	170	120	150	106	33	26	8	6-11.0	M10×25 $\varnothing$ -6	1.8
BS 85-SC	210	145	185	131	36	29	8	6-13.5	M12×30 $\varnothing$ -6	2.7
BS 95-SC	230	160	200	146	38	31	8	6-15.5	M14×35 $\varnothing$ -6	3.3
BS 110-SC	270	175	220	159	50	42	10	6-17.5	M16×40 $\varnothing$ -6	5.5
BS 135-SC	320	230	280	214	50	42	10	8-17.5	M16×40 $\varnothing$ -8	7.5
BS 160-SC	360	260	315	244	50	42	10	10-22.0	M20×45 $\varnothing$ -10	9.2
BS 200-SC	430	320	380	304	55	47	10	8-24.0	M22×50 $\varnothing$ -8	13.0

- Notes:**
1. Hexagon Socket Head Cap Screws and spring washers for installation are attached. (No painting)
  2. All models are in stock.
  3. Safety covers for BS220 to BS450 are also standardized. Please contact TSUBAKI for details.

### Installation example

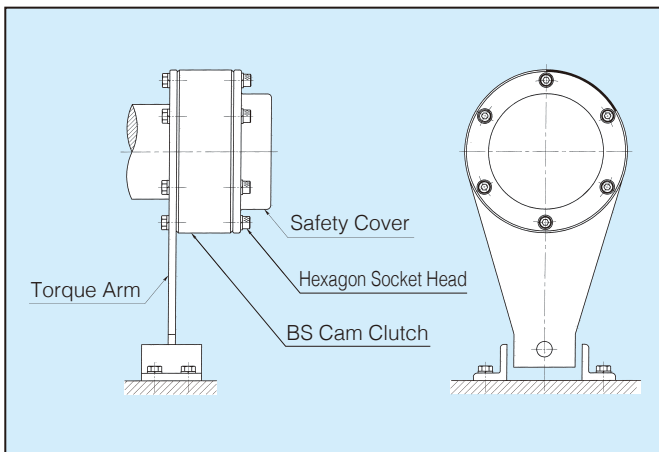

### Handling precautions

- 1) Securely fasten the attached Hexagon Socket Head Cap Screws and spring washers when installing the BS Cam Clutch.
- 2) Install the safety cover on the opposite side of the torque arm.
- 3) Refer to the manual for details.
- 4) This cover is only a safety cover; it can not be used as an oil reservoir.

# BSEU SERIES CAM CLUTCH

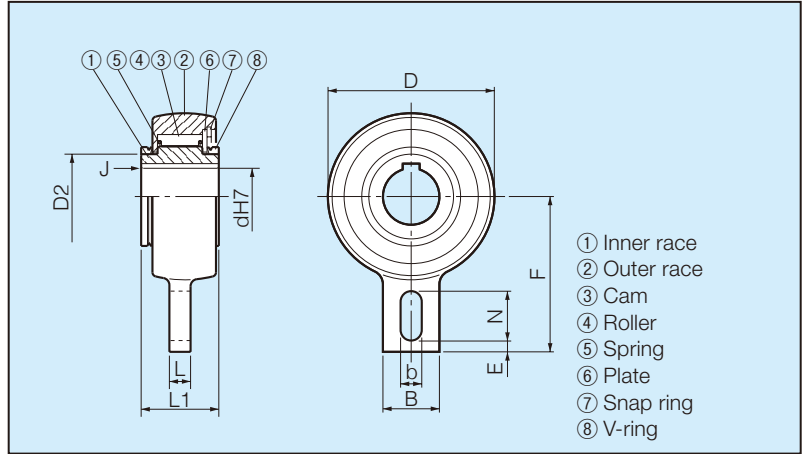
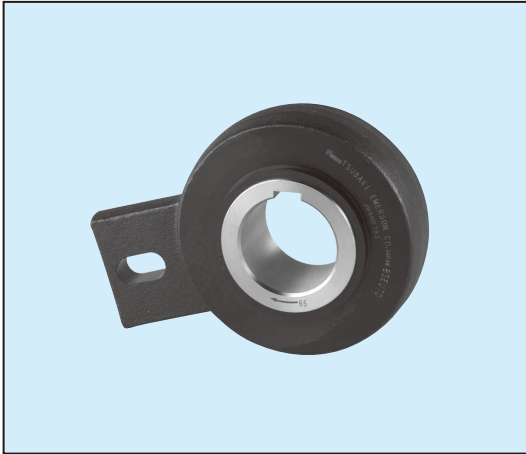

## Dimensions and Capacities

Model	Bore Size		Torque Capacity (N·m)	Max. Overrunning (r/min) Inner Race	Dimensions in mm										Weight at Minimum Bore (kg)	Weight at Maximum Bore (kg)
	Dia (H7)	Keyway			D	D2	L1	L	B	F	b	N	E	J		
BSEU25-20	20	6 × 2.8	216	500	83	42	35	12	40	90	15	35	5	1.0	1.0	0.95
BSEU25-25	25	8 × 3.3	216	500	83	42	35	12	40	90	15	35	5	1.0		
BSEU40-20	20	6 × 2.8	1440	450	118	60	55	15	40	110	15	35	8	1.5	3.8	3.4
BSEU40-25	25	8 × 3.3	1440	450	118	60	55	15	40	110	15	35	8	1.5		
BSEU40-30	30	8 × 3.3	1440	450	118	60	55	15	40	110	15	35	8	1.5		
BSEU40-35	35	10 × 3.3	1440	450	118	60	55	15	40	110	15	35	8	1.5		
BSEU40-40	40	12 × 3.3	1440	450	118	60	55	15	40	110	15	35	8	1.5		
BSEU70-45	45	14 × 3.8	3140	350	165	90	59	20	80	140	18	35	10	1.5	7.6	6.5
BSEU70-50	50	14 × 3.8	3140	350	165	90	59	20	80	140	18	35	10	1.5		
BSEU70-55	55	16 × 4.3	3140	350	165	90	59	20	80	140	18	35	10	2.0		
BSEU70-60	60	18 × 4.4	3140	350	165	90	59	20	80	140	18	35	10	2.0		
BSEU70-65	65	18 × 4.4	3140	350	165	90	59	20	80	140	18	35	10	2.0		
BSEU70-70	70	20 × 4.9	3140	350	165	90	59	20	80	140	18	35	10	2.0	10.0	9.3
BSEU90-75	75	20 × 4.9	4700	250	190	120	63	20	80	165	20	40	15	2.0		
BSEU90-80	80	22 × 5.4	4700	250	190	120	63	20	80	165	20	40	15	2.0		
BSEU90-85	85	22 × 5.4	4700	250	190	120	63	20	80	165	20	40	15	2.0		
BSEU90-90	90	25 × 5.4	4700	250	190	120	63	20	80	165	20	40	15	2.0		

### BSEU series Cam Clutch

BSEU series Cam Clutch was developed as European style Backstopping Cam Clutch which has easy usage. It has Cam & Roller construction that the roller works as a bearing same as the small size BS series Cam Clutch. The outer race has special shape which was combined the torque arm, so only stopping the rotation is required.

You can select the correct model from various bore size from 20 mm to 90 mm in each 5 mm.

Backstopping for the country elevator or the foods conveying conveyor which is used inside of the factory is the recommendation. Tsubaki recommends BS series Cam Clutch in the very dusty environment condition or the inclined conveyor and the bucket elevator which are used in outside location.

## ■ Installation and usage

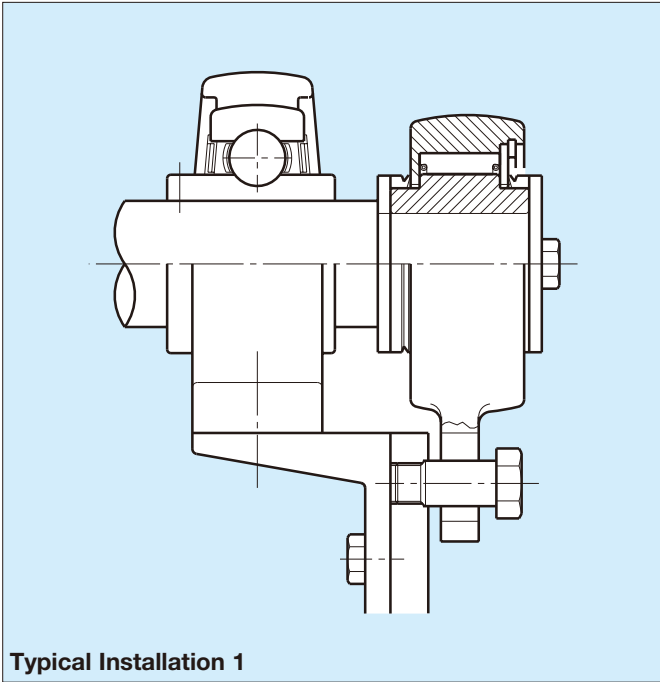

Typical Installation 1

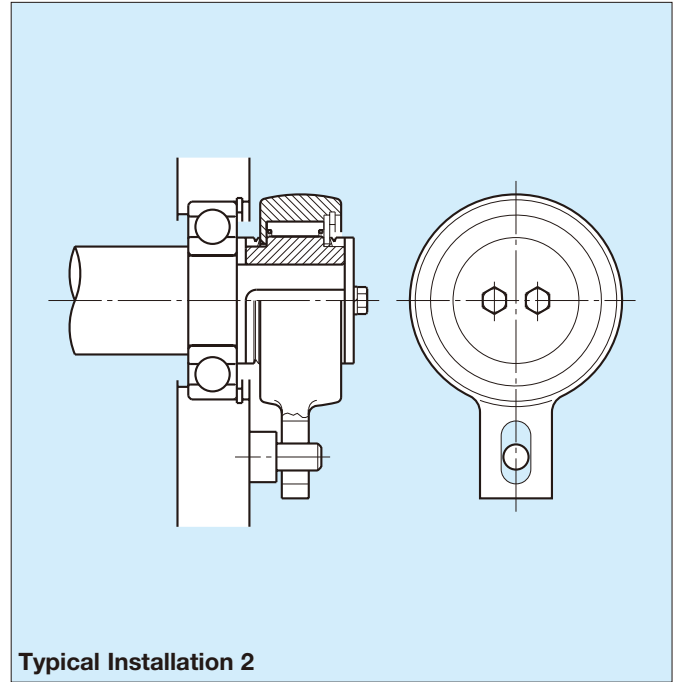

Typical Installation 2

### Installation and usage for BSEU series

1. We recommend using a shaft tolerance of h7 or h8 for Cam Clutch installation.
2. ISO R773 (DIN6885.1) keyway is standard.
3. Before installation, verify that the direction of rotation of the inner race of the Cam Clutch (shown by the arrow on the inner race) is the same as the direction of rotation of the conveyor.
4. When inserting the Cam Clutch on the shaft, apply pressure only on the surface of the inner race with a soft hammer. Never strike the Cam Clutch with a steel hammer or apply unnecessary impact loads.
5. Always use a parallel key for installation onto the shaft and then fix the Cam Clutch to the shaft with the end plate. Never use a tapered key. Allow for a clearance between the top of the clutch keyway and the top of the key for pressure ventilation.
6. Use the frame or a pin to eliminate outer race rotation.
7. Set a 0.5 mm degree clearance between the torque arm and the frame (torque arm stopper) or the long slit in the torque arm and the pin. If the torque arm is rigidly mounted, it will apply a load to the Cam Clutch which may eventually damage it.
8. The Cam Clutch is pre-packed with low temperature grease before shipment and is ready for installation and operation. No lubrication maintenance is required. The ambient operational temperature range is  $-40^{\circ}$  to  $50^{\circ}\text{C}$ . However, the maximum temperature should be determined depending on the number of shaft revolutions. Further, if the number of shaft revolutions is low, a higher ambient operational temperature range is allowable. Consult with Tsubaki for more details.
9. The cover is recommended to protect from direct sunlight or dust to avoid the the excess heating of unit and potential damage to sealing in case of outdoor usage.

# BR-HT SERIES CAM CLUTCH

## MODELS BR15HT TO BR130HT

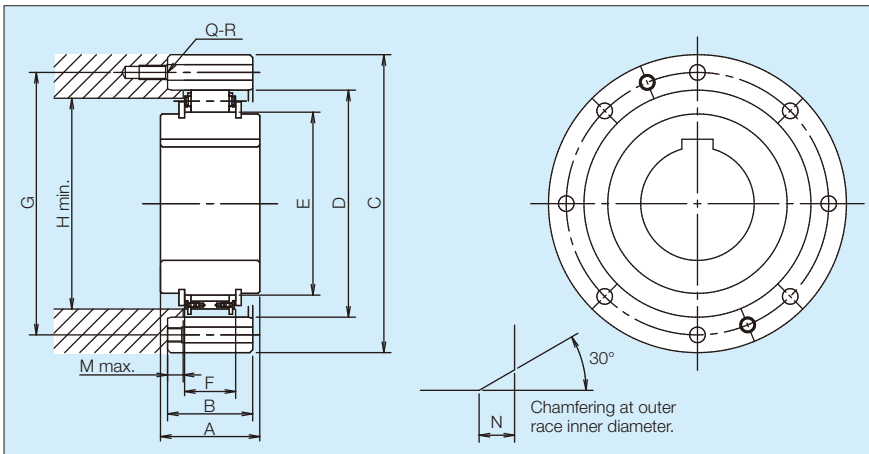

### Format

## BR40HT - R66B - 35

Bore size  
 Size & Length of cam  
 A, B, C, D type  
 WA/WB/WC/WD type  
 (W=Double cam cage)  
 Model name  
 HT=High Torque

### Dimensions and Capacities

Dimensions in mm

Model	Bore Size (H7)	Torque Capacity (N·m)	Inner Race Overrunning Speed (r/min)		Max. Engagement (r/min)	A	B	C	D (H7)	E	Mounting Holes		F	Min. Mass (kg)	Max. Mass (kg)	H min.	M max.	Chamfer N
			Min.	Max.							PCD G	Q'ty-Size Q-R						
BR15HT-R31A	*20	105	880	3600	550	24	25	85	55	30	70	6-M6	17.0	-	0.8	45	3	1
BR18HT-R38A	*25	155	850	3600	500	24	25	90	62	37	75	6-M6	17.0	-	0.9	50	3	1
BR20HT-S20B	20	225	850	3600	400	35	35	90	66	41	78	6-M6	25.0	-	1.3	53	4	1
BR25HT-B46B	25 30	400	800	3600	380	35	35	95	70	45	82	6-M6	25.0	1.4	1.4	58	4	1
BR30HT-S30B	30	500	740	3600	360	35	35	100	75	50	87	6-M6	25.0	-	1.5	64	4	1
BR30HT-R51B	25 30 35 36	500	740	3600	360	35	35	105	75	50	90	6-M6	25.0	1.7	1.8	64	4	1
BR35HT-B56B	35 40	600	710	3600	340	35	35	110	80	55	96	8-M6	25.0	1.8	1.9	70	4	1
BR38HT-R61A	30 35 40 *45	425	740	3600	400	25	25	120	85	60	105	6-M8	19.0	1.6	1.8	74	3	1
BR40HT-S40B	40	850	670	3600	320	35	35	125	90	65	108	8-M8	25.0	-	2.4	82	4	1
BR40HT-R66B	35 40 45 *48	850	670	3600	320	35	35	132	90	65	115	8-M8	25.0	2.7	2.9	82	4	1
BR45HT-S45B	45	950	640	3600	310	35	35	130	95	70	112	8-M8	25.0	-	2.6	86	4	1
BR48HT-R76B	45 55 *60	1100	620	3600	300	35	35	140	100	75	125	8-M8	25.0	2.9	3.3	92	4	1
BR50HT-B86B	40 45 50 60 65 *70	1450	590	3600	280	40	40	150	110	85	132	8-M8	25.0	3.5	4.3	103	6.5	1
BR58HT-R101B	55 70 *80	1800	550	3600	260	50	50	175	125	100	155	8-M10	25.0	5.8	6.7	117	11.5	1
BR60HT-B85A	45 50 60 65	2400	420	3600	230	60	50	175	125	92	155	8-M10	36.0	6.8	7.6	110	6	1
BR70HT-B100A	45 50 55 60 70 75 *80	3150	390	3600	220	60	50	190	140	107	165	12-M10	36.0	7.6	9.2	125	6	1.5
BR80HT-S80A	80	5000	440	3600	200	70	60	210	160	127	185	12-M10	36.0	-	12	148	11	1.5
BR80HT-B120B	60 65 70 75 80 95	7000	310	3600	160	70	60	210	160	127	185	12-M10	50.0	11	13	148	4	1.5
BR90HT-S90A	90	6000	410	3000	190	80	70	230	180	147	206	12-M12	36.0	-	16	170	16	2
BR90HT-B140B	65 90 100 110	9000	300	3000	150	70	70	245	180	147	218	12-M12	50.0	17	20	170	9	2
BR95HT-S100C	100	20500	240	2700	130	90	80	290	210	177	258	12-M16	63.0	-	33	200	7.5	2
BR95HT-R170C	70 85 90 100 120 130	20500	240	2700	130	80	80	290	210	177	258	12-M16	63.0	29	35	200	7.5	2
BR98HT-R200C	120 130 155	27000	230	2100	110	80	80	310	240	207	278	12-M16	63.0	30	33	230	7.5	2
BR100HT-S100A	100	11000	440	2700	210	90	80	290	210	143	258	12-M16	52.6	-	28	200	11.5	2
BR130HT-S130A	130	16000	400	2400	190	90	80	322	240	173	278	12-M16	52.6	-	33	210	11.5	2

- Notes:**
- The maximum transmissible torque is twice the Torque Capacity
  - Keyway No Mark on Bore Size...ISOR773/DIN6885.1  
\* Mark on Bore Size...DIN6885.3
  - Min. overrunning speed of inner race should not be below under continuous operation.
  - Max. engagement speed must not be exceeded when transmitting torque.
  - Check stress applied to key. Depending on the stress value, heat treatment of the key may be necessary.

### Recommended Cover Dimension Table

Dimensions in mm

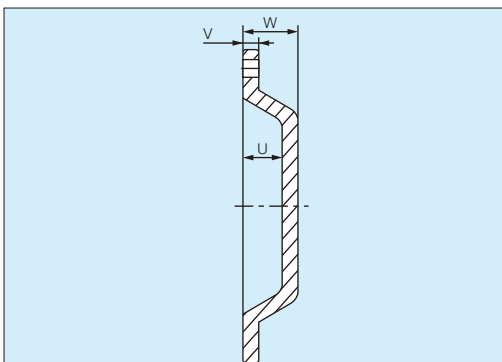

Model	Width		Depth
	W	V	U
BR15HT to BR38HT	21	8	15
BR40HT to BR50HT	23	11	17
BR58HT to BR60HT	28	11	22
BR70HT to BR95HT-S100C	35	11	29
BR95HT-R170C to BR130HT	42	15	33
BR180HT	60	15	48
BR190HT to BR230HT	60	18	48
BR240HT to BR300HT	68	26	56

## MODELS BR180HT TO BR300HT

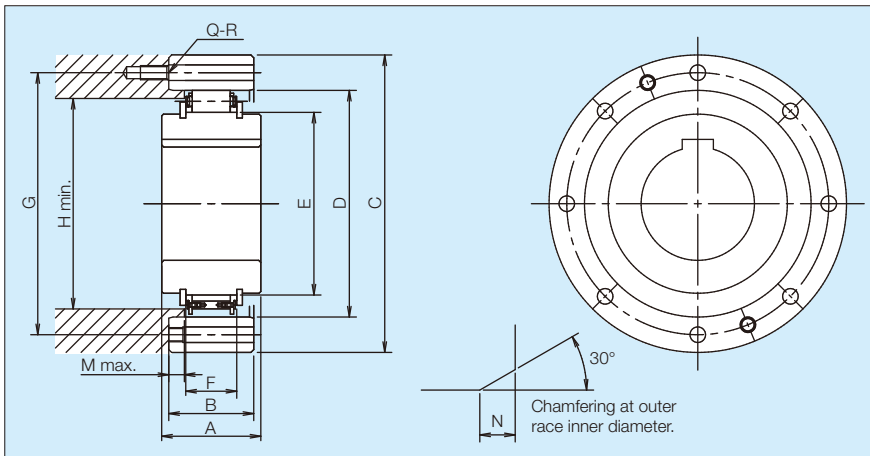

### Format

## BR180HT - S180A - 180

Bore size  
 Size & Length of cam  
 A, B, C, D type  
 WA/WB/WC/WD type  
 (W=Double cam cage)  
 Model name  
 HT=High Torque

### Dimensions and Capacities

Dimensions in mm

Model	Bore Size (H7)	Torque Capacity (N·m)	Inner Race Overrunning Speed (r/min)		Max. Engagement (r/min)	A	B	C	D (H7)	E	Mounting Holes		F	Mass (kg)	H min.	M max.	Chamfer N
			Min.	Max.							PCD G	Q'ty-Size Q-R					
BR180HT-S180A	180	32000	300	1300	160	90	80	412	310	243	360	12-M20	53	56	280	11.5	2
BR180HT-S180C	180	53000	250	1300	120	120	120	422	310	243	370	18-M20	83	85	280	16.5	2
BR180HT-S180WA	180	64000	300	1300	160	160	160	412	310	243	360	24-M20	106	107	280	30	2
BR180HT-S180WC	180	106000	250	1300	120	240	240	425	310	243	370	24-M24	166	174	280	35	2
BR180HT-R240A	185	32000	220	1300	110	90	80	400	310	243	360	12-M20	53	50	280	11.5	2
BR180HT-R240D	185	64000	210	1300	100	120	125	420	310	243	370	16-M24	96	84	280	12.5	2
BR180HT-R240WB	185	70000	220	1300	110	160	160	412	310	243	360	24-M20	140	100	280	8	2
BR180HT-R240WD	185	128000	210	1300	100	240	240	425	310	243	370	24-M24	192	163	280	22	2
BR190HT-R260A	205	39000	200	1300	95	105	80	430	330	263	380	16-M20	53	60	300	11.5	2
BR220HT-S220A	220	45000	280	1100	140	105	80	470	360	293	410	16-M20	53	74	330	11.5	2
BR220HT-S220C	220	70000	230	1100	110	120	120	480	360	293	410	16-M24	83	100	330	16.5	2
BR220HT-S220WA	220	90000	280	1100	140	160	160	480	360	293	430	18-M24	106	141	330	25	2
BR220HT-S220WC	220	140000	230	1100	110	240	240	490	360	293	425	20-M30	166	215	330	35	2
BR220HT-R290B	230	60000	195	1100	115	105	80	460	360	293	410	16-M20	70	87	330	3	2
BR220HT-R290D	230	92000	190	1100	95	120	110	460	360	293	410	16-M20	96	146	330	5	2
BR220HT-R290WB	230	120000	195	1100	115	160	160	480	360	293	410	18-M24	140	120	330	8	2
BR220HT-R290WD	230	184000	190	1100	95	240	240	490	360	293	425	20-M30	192	206	330	22	2
BR230HT-R310B	240	70000	190	1100	90	110	125	497	380	313	450	24-M20	70	110	350	25.5	3
BR230HT-R310D	240	110000	185	1100	80	120	125	497	380	313	450	24-M20	96	116	350	12.5	3
BR240HT-S240A	240	54000	220	1100	120	105	90	500	390	323	440	16-M20	53	91	360	16.5	3
BR240HT-S240C	240	88000	185	1100	110	120	120	520	390	323	440	16-M24	83	129	360	16.5	3
BR240HT-S240WA	240	108000	220	1100	120	180	180	520	390	323	440	24-M24	106	161	360	35	3
BR240HT-S240WC	240	176000	185	1100	110	240	240	530	390	323	455	24-M30	166	249	360	35	3
BR240HT-R320B	250	77000	190	1100	115	105	80	490	390	323	440	16-M24	70	78	360	3	3
BR240HT-R320D	250	113000	180	1100	105	120	120	520	390	323	440	16-M24	96	128	360	10	3
BR240HT-R320WB	250	154000	190	1100	115	180	180	505	390	323	440	24-M24	140	173	360	18	3
BR240HT-R320WD	250	226000	180	1100	105	240	240	530	390	323	460	24-M30	192	259	360	22	3
BR260HT-S260A	260	66000	250	1000	130	105	105	550	430	363	500	16-M24	57	122	400	22	3
BR260HT-S260C	260	110000	190	1000	100	125	125	580	430	363	500	24-M24	87	170	400	17	3
BR260HT-S260WA	260	132000	250	1000	130	210	210	580	430	363	500	24-M24	114	235	400	46	3
BR260HT-S260WC	260	220000	190	1000	100	250	250	580	430	363	500	24-M30	174	323	400	36	3
BR260HT-R360D	280	150000	170	1000	90	125	120	540	430	363	500	24-M24	100	127	400	8	3
BR260HT-R360WB	280	196000	175	1000	95	210	210	550	430	363	500	24-M24	148	227	400	29	3
BR260HT-R360WD	280	300000	170	1000	90	250	250	580	430	363	500	24-M30	200	311	400	23	3
BR300HT-S300A	300	82000	230	1000	120	105	105	630	480	413	560	24-M24	57	163	460	22	3
BR300HT-S300C	300	140000	200	1000	95	125	125	630	480	413	560	24-M24	87	198	460	17	3
BR300HT-S300WA	300	164000	230	1000	120	210	210	630	480	413	560	24-M24	114	324	460	46	3
BR300HT-R410D	300 320	195000	165	1000	85	125	120	630	480	413	560	24-M24	100	186	460	8	3
BR300HT-R410WB	300 320	250000	165	1000	85	210	210	630	480	413	560	24-M24	148	314	460	29	3
BR300HT-R410WD	300 320	366000	165	1000	85	220	220	630	480	413	560	24-M30	200	324	460	8	3

Notes: 1. The maximum transmissible torque is twice the Torque Capacity

2. Keyway No Mark on Bore Size...ISOR773/DIN6885.1

\* Mark on Bore Size...DIN6885.3

3. Min. overrunning speed of inner race should not be below under continuous operation.

4. Max. engagement speed must not be exceeded when transmitting torque.

5. Check stress applied to key. Depending on the stress value, heat treatment of the key may be necessary.

## ■ INSTALLATION AND USAGE

While the Cam Clutch can be disassembled by the user, reassembly may prove difficult. We recommend that you install the Cam Clutch as delivered.

There are removal hole at the end face of the outer race. Install the Cam Clutch so that it comes to the installation face.

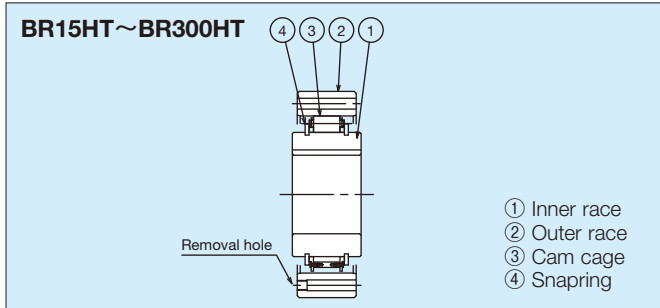

### Installation and Usage

- We recommend using shaft tolerances of h6 or h7 for Cam Clutch installation.
- Use ISO R773/DIN 6885.1 Parallel key or DIN6885.3 Parallel key for models marked \* on page 3. Ensure that the key does not move in the keyway. A loose key will damage the Cam Clutch.
- Align the key to slide through the keyway smoothly before installation.
- When installing the Cam Clutch over a shaft, please follow the procedure outlined below. Never strike the clutch with a steel hammer or apply unnecessary impact loads.
  - Verify Cam Clutch direction of rotation. The arrow on the inner race shows the free running (cam disengaged) direction. Make sure that the direction of cam engagement matches the intended application.
  - Tap the inner race lightly with a soft hammer moving around the race circumference so the Cam Clutch moves slowly and uniformly onto the end of the shaft. Make sure that the outer race does not become dislodged.
  - Place an end plate over the inner race and use the mounting bolts to pull the Cam Clutch onto the shaft as shown in Installation Method at right.
  - Fix the end plate securely.
- If you are installing the outer race first, check the precision of the fit. The tolerances for outer race mounting are shown in the tables at right. Verify that the correct tolerances can be obtained. Out of spec installation could damage the Cam Clutch.
- Non-lubricated when shipping please lubricate before use. To lubricate the Cam Clutch, apply lubricant at the outer circumference of the inner race (see Typical Installation 1). Avoid over lubrication, as it will cause the Cam Clutch to generate excessive heat.
- BR-HT Series accept lubricant generally used in gear reducer. It is possible to mount BR-HT directly in gearbox without separate lubrication.
- When installing a cover or seal support over the outer race, use bolts with a tensile rating of 10.9 or greater. Use a sealing agent or packing material between the mating services to prevent leakage.

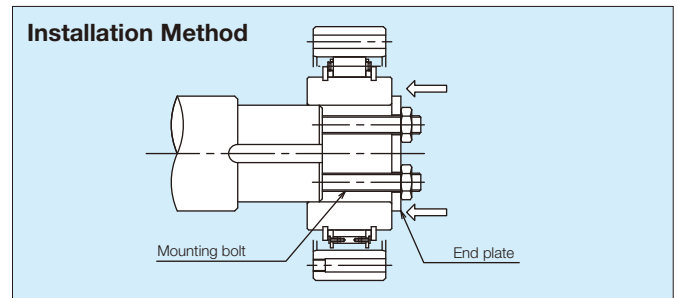
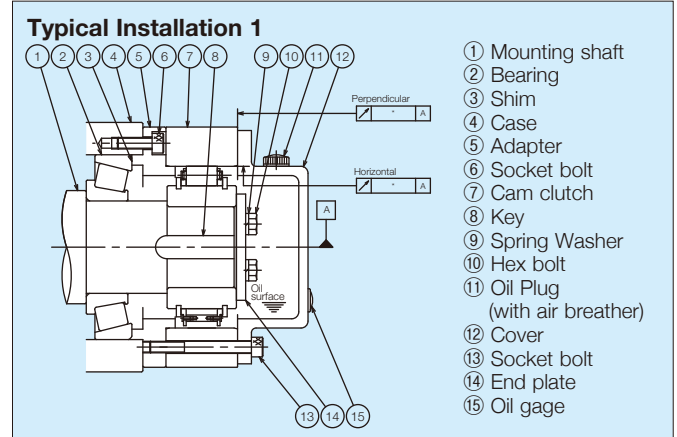

### Parallel Tolerances

Model	Parpadicular (mm)
BR15HT to BR58HT	0.10
BR60HT to BR98HT	0.15
BR100HT and above	0.25

### Right Angle Tolerances

Model	Horizontal (mm)
BR15HT to BR58HT	0.04
BR60HT to BR98HT	0.06
BR100HT and above	0.08

## ■ LUBRICATION FOR THE BR-HT SERIES

BR-HT Series Cam Clutch needs periodic maintenance and lubrication to provide maximum performance throughout their service life. Lack of the prescribed maintenance and lubrication will shorten the Cam Clutch's service life and may result in unnecessary mechanical damage. BR-HT Cam Clutch can be lubricated with oil or depending on the type of application.

### Recommended Oil

Brand	Type
ENEOS	FBK Turbine32, Automatic D2
Shell Lubricants Japan	Rimura D Oil 10W, Turbo Oil T32
EMG Lubricants	DTE Oil Light, ATF220

- The above oils are recommended for operating environments ranging from -5°C to +40°C. Contact TSUBAKI when the enviromental temperature is out of this range.
- Special Cam Clutch oil (1 litre can) is available from TSUBAKI.

# BR-P SERIES CAM CLUTCH

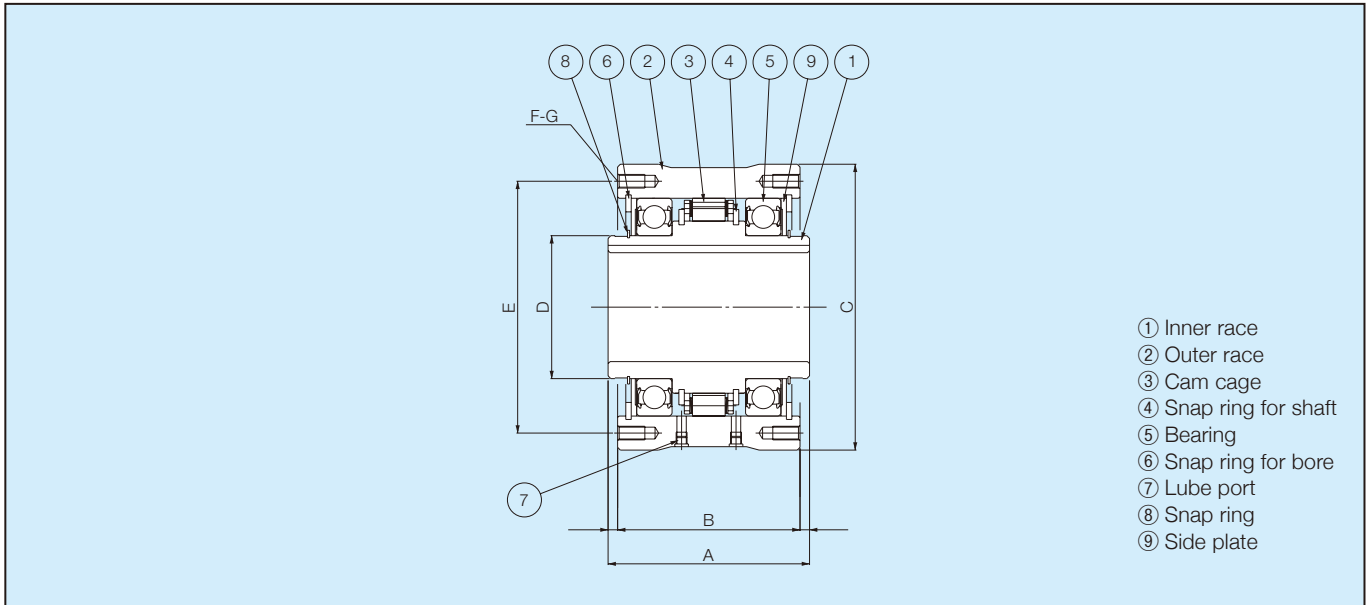

**Note:** Above drawing is an example. Request a certified drawing when ordering, as specifications vary with each model.

## Dimensions and Capacities

Dimensions in mm

Model	Torque Capacity (N·m)	Inner Race Overrunning Speed		Max. Engagement (r/min)	Bore Size (H7)	Keyway	A	B	C (h7)	D	PCD E	F-G	Weight (kg)
		Min. (r/min)	Max. (r/min)										
BR 20P	306	880	3600	350	20	6×2.8	87	79	94	35	78	6-M 6×12	3.4
BR 25P	384	880	3600	350	25	8×3.3	89	81	98	40	82	6-M 6×12	3.8
BR 30P	607	880	3600	350	30	8×3.3	94	85	103	45	87	6-M 6×12	4.3
BR 35P	686	780	3600	300	35	10×3.3	94	85	112	50	96	8-M 6×12	5.1
BR 40P	980	720	3600	300	40	12×3.3	100	91	130	55	108	8-M 8×16	7.5
BR 45P	1078	670	3600	280	45	14×3.8	100	91	135	60	112	8-M 8×16	7.9
BR 50P	1715	610	3600	240	50	14×3.8	107	98	152	70	132	8-M 8×16	10.9
BR 60P	3479	490	3600	200	60	18×4.4	122	112	180	80	155	8-M10×20	17.5
BR 70P	4735	480	3600	200	70	20×4.9	128	118	190	90	165	12-M10×20	19.5
BR 80P	6517	450	3600	190	80	22×5.4	148	134	210	105	185	12-M10×20	27
BR 90P	8526	420	3000	180	90	25×5.4	152	138	235	120	206	12-M12×24	35
BR100P	14210	460	2500	180	100	28×6.4	186	172	275	140	240	12-M16×32	60
BR130P	20384	420	2200	180	130	32×7.4	208	188	314	160	278	12-M16×32	80
BR150P	33908	370	1300	160	150	36×8.4	226	204	400	200	360	12-M16×32	151
BR180P	33908	370	1800	160	180	45×10.4	240	218	400	220	360	12-M16×32	169
BR190P	41160	340	1800	140	190	45×10.4	250	242	420	240	380	16-M16×32	193
BR220P	51058	330	1800	140	220	50×11.4	250	242	460	260	410	18-M16×32	220
BR240P	62034	310	1800	130	240	56×12.4	260	252	490	280	440	18-M16×32	267

- Notes:**
1. Package type Cam Clutches are all made to order. To order, please refer to the dimension diagram. Please inform us if the Cam Clutch is to be used in a vertical application, and if the operating environment temperature will be less than  $-5^{\circ}\text{C}$  or more than  $+40^{\circ}\text{C}$ .
  2. There are cases when the free running rotation speed of the inner race will be limited when package type Cam Clutches are installed horizontally.
  3. If your application calls for a clutch engagement speed or inner race free running speed not listed in this catalog, please contact TSUBAKI .

## ■ USING THE BR SERIES PACKAGE TYPE CAM CLUTCH

The package type Cam Clutch is designed into a ball bearing cassette that makes installation with a torque arm or coupling fast and easy. The package type Cam Clutch is grease lubricated.

### Installation and Usage

1. We recommend using shaft tolerances of h6 or h7 for Cam Clutch installation.
2. Use a ISO R773 (DIN 6885.1) parallel key. Make sure that the key does not move in the keyway. A loose key will damage the Cam Clutch.
3. Align the key to slide through the keyway smoothly before installation.
4. When installing the Cam Clutch over a shaft, please follow the procedure outlined below. Never hit the clutch with a steel hammer or apply unnecessary impact loads.
  - 1) Verify the Cam Clutch direction of rotation. The arrow on the inner race shows the free running (cam disengaged) direction. Make sure that the direction of cam engagement matches the intended application.
  - 2) Tap the inner race lightly with a soft hammer moving around the race circumference so the Cam Clutch moves slowly and uniformly onto the end of the shaft. Make sure that the outer race does not become dislodged.
  - 3) Place an end plate over the inner race and use the mounting bolts to pull the Cam Clutch onto the shaft as shown in the diagram at right.
  - 4) Tighten the end plate securely to make sure that the Cam Clutch cannot move on the shaft.
5. If you using a torque arm, make sure that the bolts used to mount the torque arm have a tensile strength of 10.9 or greater, and tighten them securely.
6. Set a 2mm clearance between the torque arm and the torque arm stopper. If the torque arm is rigidly mounted, it will be applying a load to the Cam Clutch which can eventually damage it.
7. Install an appropriate coupling if there is a chance that the shaft will elongate from thermal expansion as encountered in some exhaust fan auxiliary drive system applications.
8. If thrust loads are encountered, install a thrust bearing which will prevent those thrust loads from being transferred to the Cam Clutch.
9. The Cam Clutch is pre-packed with grease before shipment and is ready for installation and operation. Refer to page 80 for lubrication guidelines.

### Horizontal Installation

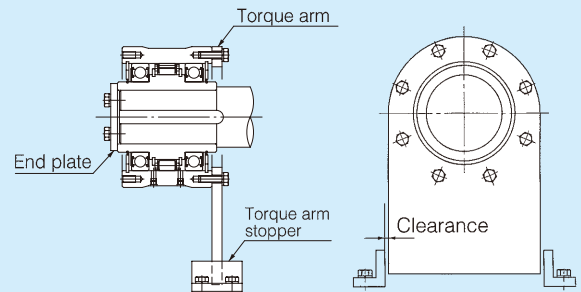

Installation example 1:

### Vertical Installation

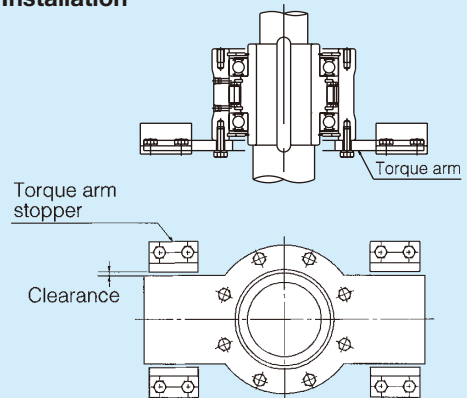

Installation example 2:

### Flexible Coupling Installation

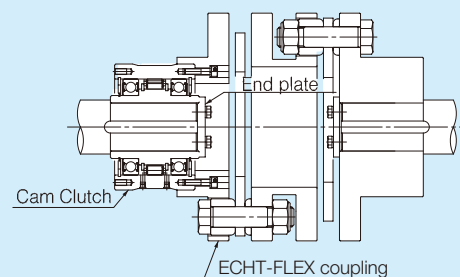

Installation example 3:

# BREU SERIES CAM CLUTCH

## Capacities

Model	Torque Capacity (N·m)	Inner Race Overrunning Speed		Max. Engagement Speed (r/min)
		Min. (r/min)	Max. (r/min)	
BREU 30 (K)	607	880	3600	350
BREU 35 (K)	686	780	3600	300
BREU 40 (K)	980	720	3600	300
BREU 45 (K)	1078	670	3600	280
BREU 50 (K)	1715	610	3600	240
BREU 55 (K)	1960	580	3600	220
BREU 60 (K)	3479	490	3600	200
BREU 70 (K)	4735	480	3600	200
BREU 80 (K)	6517	450	3600	190
BREU 90 (K)	8526	420	3000	180
BREU100 (K)	14210	460	2500	180
BREU130 (K)	20384	420	2200	180
BREU150 (K)	33908	370	1300	180

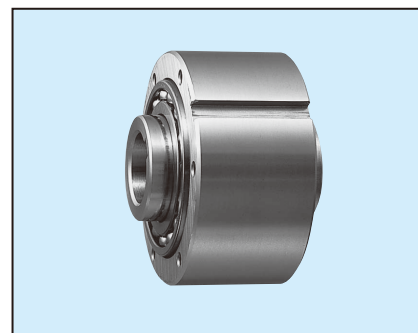

## General Information for Installation and Usage

- BREU series is a modular type Cam Clutch which is delivered as a BREU series Basic type or BREU-K series with option parts (E1, E2, E5, E7 flanges, E3 Torque arm and E4 cover) which are required as separate parts.
- All models are pre-greased.  
The operational temperature range is  $-40^{\circ}\text{C}$  to  $+40^{\circ}\text{C}$ .  
Too much additional grease to both bearing inhibits the basic Cam Clutch function. Refer to page 80 for the maintenance.
- We recommend a Shaft tolerance of h7, and DIN6885.1 keyway is standard.
- Align the key to slide through the keyway smoothly before installation.
- We recommend tolerance of B and E H7 or H8 for sprockets, gears and other fitted parts.
- Clean the surface of both end of the outer race and the contact surfaces of the flanges, torque arm and cover.
- Verify the direction of rotation and attach the flanges, torque arm or cover.
- When installing sprocket, gear, and other equipment to the clutch, fit them on the surface of the flange by using hexagon socket cap screws.
- By installing each option part on the opposite side, the direction of rotation can be changed.
- Fix the grease nipple and set screw to the option parts.
- When mounting the clutch onto the shaft, apply pressure to the inner race but never to the outer race. Tap the inner race lightly with a soft hammer moving around the race circumference so the Cam Clutch moves slowly and uniformly onto the end of the shaft.
- Do not use grease that contains EP additives.
- Model No. BREU K
  - No Mark : No keyway on the outer race.
  - K : Keyway on the outer race.

## BREU Basic series and BREU-K series

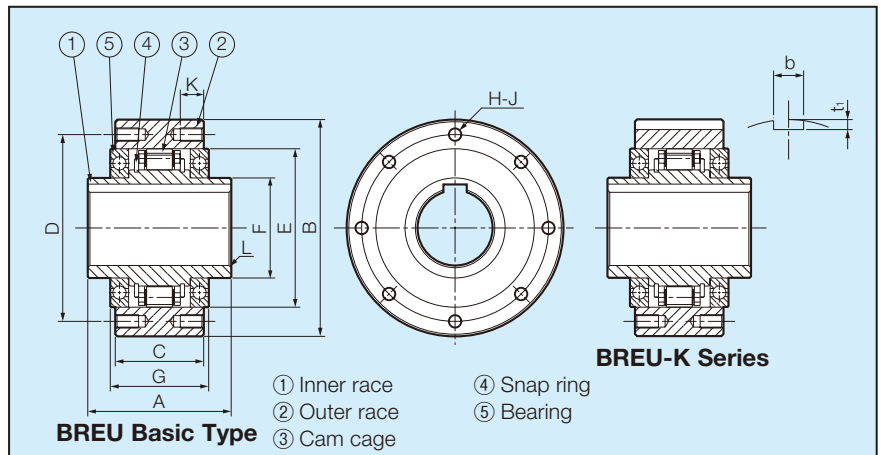
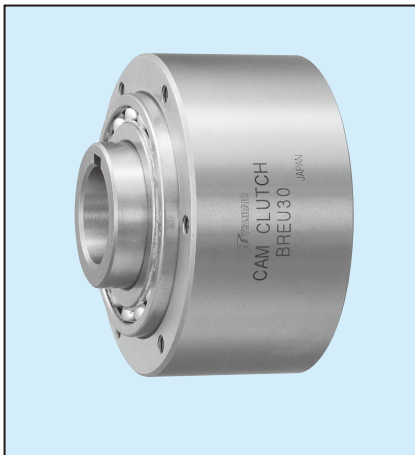

### Dimensions

Dimensions in mm

Model	Bore Size (H7)	Inner Race Keyway	A	B (h7)	C	PCD D	E	F	G	H-J	K	L (C)	b (P10)	t <sub>1</sub>	Weight (kg)
BREU 30 (K)	30	8×3.3	76	100	51	87	75	45	56	6-M6	10	1.0	8	4.0	2.7
BREU 35 (K)	35	10×3.3	79	110	50	96	80	50	56	6-M6	12	1.0	10	5.0	3.2
BREU 40 (K)	40	12×3.3	86	125	53	108	90	55	59	6-M8	14	1.3	12	5.0	4.4
BREU 45 (K)	45	14×3.8	86	130	53	112	95	60	59	8-M8	14	1.3	14	5.5	4.7
BREU 50 (K)	50	14×3.8	94	150	64	132	110	70	72	8-M8	14	1.3	14	5.5	7.6
BREU 55 (K)	55	16×4.3	104	160	66	138	115	75	72	8-M10	16	1.5	16	6.0	8.9
BREU 60 (K)	60	18×4.4	120	170	84	150	125	80	95	10-M10	16	1.5	18	7.0	12.5
BREU 70 (K)	70	20×4.9	134	190	95	165	140	90	108	10-M10	16	1.8	20	7.5	17.2
BREU 80 (K)	80	22×5.4	144	210	100	185	160	105	108	10-M10	16	1.8	22	9.0	22.4
BREU 90 (K)	90	25×5.4	158	230	115	206	180	120	125	10-M12	20	2.0	25	9.0	30.3
BREU100 (K)	100	28×6.4	186	270	124	240	210	140	135	10-M16	24	2.0	28	10.0	45.5
BREU130 (K)	130	32×7.4	212	310	152	278	240	160	168	12-M16	24	2.5	32	11.0	67.0
BREU150 (K)	150	36×8.4	246	400	180	360	310	200	194	12-M20	32	2.5	36	12.0	145.0

### Installation and Usage

1. By installing both parts on the opposite side, the direction of rotation can be changed.
2. Align the key to slide through the keyway smoothly before installation.
3. When mounting the clutch onto the shaft, apply pressure to the inner race but never to the outer race. Tap the inner race lightly with a soft hammer moving around the race circumference so the Cam Clutch moves slowly and uniformly onto the end of the shaft.
4. All models are pre-greased.  
The ambient temperature range is  $-40^{\circ}\text{C}$  to  $+40^{\circ}\text{C}$ .  
Too much additional grease to both bearing inhibits the basic Cam Clutch function. Refer to page 80 for the maintenance.
5. Refer to page 59 for other general information.
6. Please refer to page 64 for dimension of keyway on the outer race.

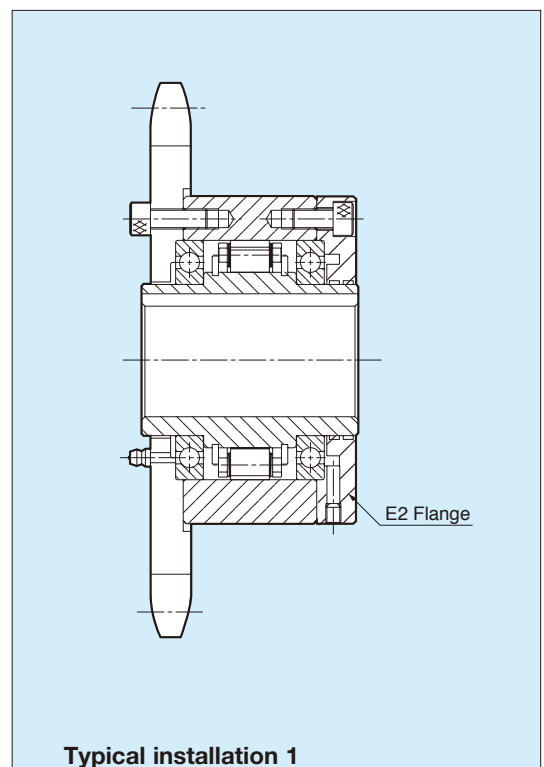

## E1 Flange + E2 Flange

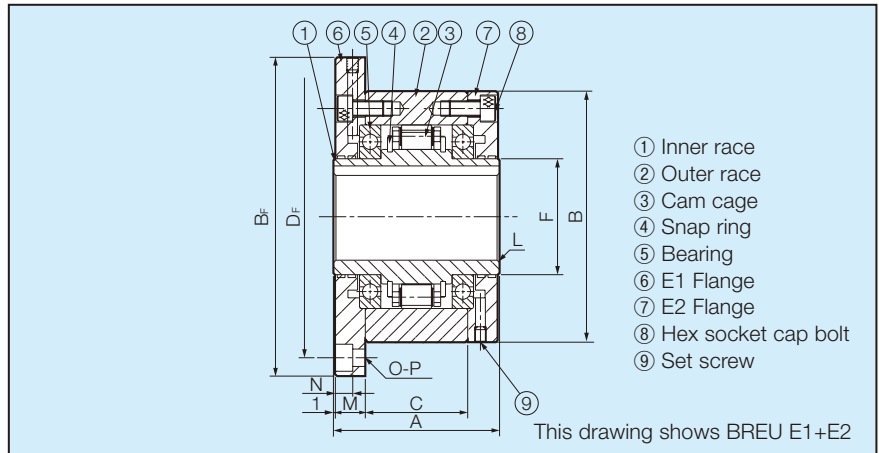

### Dimensions

Dimensions in mm

Model	Bore Size (H7)	Inner Race Keyway	A	B (h7)	B <sub>F</sub>	C	D <sub>F</sub>	F	L (C)	M	N	O-P	Weight (kg)
BREU 30 (K) E1+E2	30	8×3.3	76	100	128	51	114	45	1.0	11.5	6.8	6-φ6.6	4.1
BREU 35 (K) E1+E2	35	10×3.3	79	110	140	50	124	50	1.0	13.5	6.8	6-φ6.6	5.2
BREU 40 (K) E1+E2	40	12×3.3	86	125	160	53	142	55	1.3	15.5	9.0	6-φ9.0	7.5
BREU 45 (K) E1+E2	45	14×3.8	86	130	165	53	146	60	1.3	15.5	9.0	8-φ9.0	7.9
BREU 50 (K) E1+E2	50	14×3.8	94	150	185	64	166	70	1.3	14.0	9.0	8-φ9.0	11.1
BREU 55 (K) E1+E2	55	16×4.3	104	160	204	66	182	75	1.5	18.0	11.0	8-φ11.0	14.7
BREU 60 (K) E1+E2	60	18×4.4	120	170	214	84	192	80	1.5	17.0	11.0	10-φ11.0	17.9
BREU 70 (K) E1+E2	70	20×4.9	134	190	234	95	212	90	1.8	18.5	11.0	10-φ11.0	24.5
BREU 80 (K) E1+E2	80	22×5.4	144	210	254	100	232	105	1.8	21.0	11.0	10-φ11.0	32.5
BREU 90 (K) E1+E2	90	25×5.4	158	230	278	115	254	120	2.0	20.5	13.0	10-φ14.0	40.5
BREU100 (K) E1+E2	100	28×6.4	186	270	335	124	305	140	2.0	30.0	17.5	10-φ18.0	68.0
BREU130 (K) E1+E2	130	32×7.4	212	310	380	152	345	160	2.5	29.0	17.5	12-φ18.0	95.0
BREU150 (K) E1+E2	150	36×8.4	246	400	485	180	445	200	2.5	32.0	21.5	12-φ22.0	197.0

### Installation and Usage

1. By installing E1 flange and E2 flange on the opposite side, the direction of rotation can be changed.
2. Align the key to slide through the keyway smoothly before installation.
3. When mounting the clutch onto the shaft, apply pressure to the inner race but never to the outer race. Tap the inner race lightly with a soft hammer moving around the race circumference so the Cam Clutch moves slowly and uniformly onto the end of the shaft.
4. All models are pre-greased.  
 The ambient temperature range is -40°C to +40°C.  
 Too much additional grease to both bearing inhibits the basic Cam Clutch function. Refer to page 80 for the maintenance.
5. Refer to page 59 for other general information.

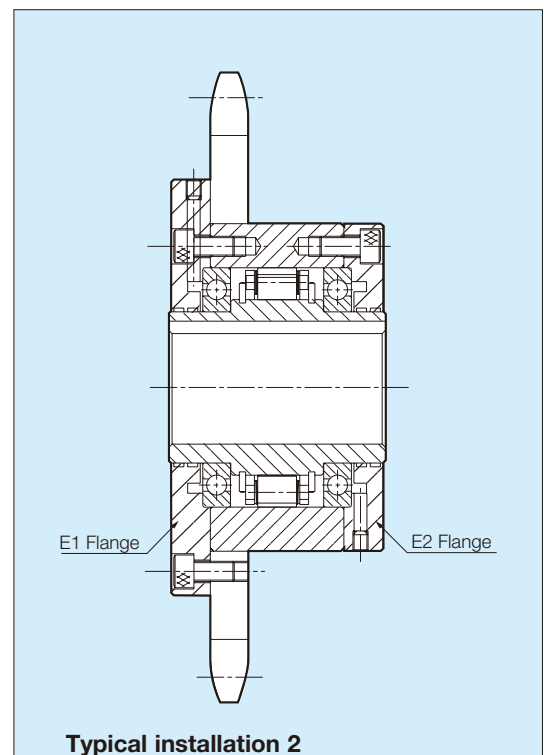

## E2 Flange + E3 Torque arm

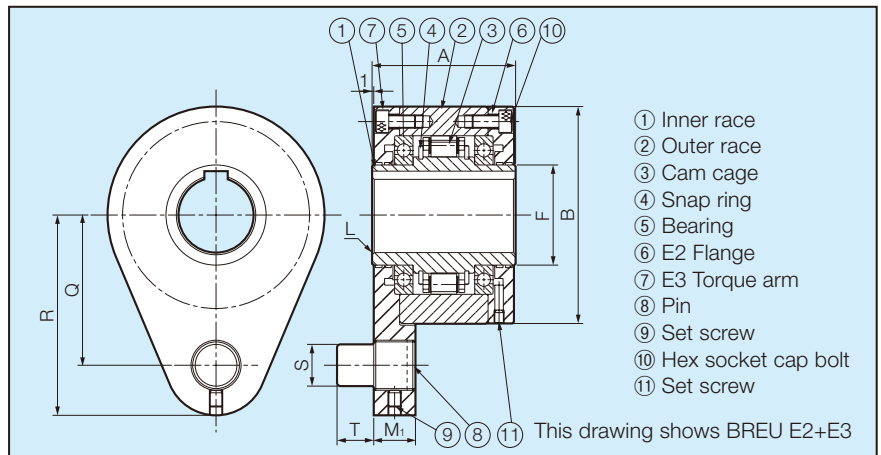
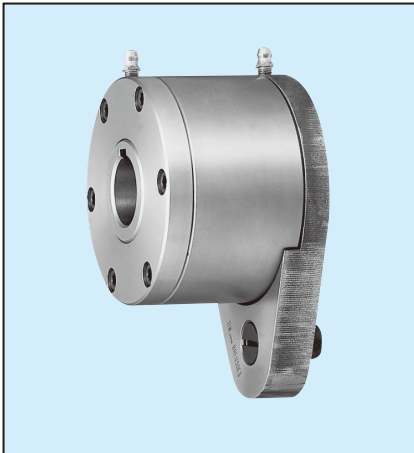

### Dimensions

Dimensions in mm

Model	Bore Size (H7)	Inner Race Keyway	A	B (h7)	F	L (C)	M <sub>1</sub>	Q	R	S	T	Weight (kg)
BREU 30 (K) E2+E3	30	8×3.3	76	100	45	1.0	19	68	92	16	14	4.2
BREU 35 (K) E2+E3	35	10×3.3	79	110	50	1.0	22	76	102	20	18	5.0
BREU 40 (K) E2+E3	40	12×3.3	86	125	55	1.3	22	85	112	20	18	7.0
BREU 45 (K) E2+E3	45	14×3.8	86	130	60	1.3	25	90	120	25	22	7.7
BREU 50 (K) E2+E3	50	14×3.8	94	150	70	1.3	25	102	135	25	22	11.0
BREU 55 (K) E2+E3	55	16×4.3	104	160	75	1.5	30	108	142	32	25	14.0
BREU 60 (K) E2+E3	60	18×4.4	120	170	80	1.5	30	112	145	32	25	17.2
BREU 70 (K) E2+E3	70	20×4.9	134	190	90	1.8	35	135	175	38	30	24.5
BREU 80 (K) E2+E3	80	22×5.4	144	210	105	1.8	35	145	185	38	30	31.9
BREU 90 (K) E2+E3	90	25×5.4	158	230	120	2.0	45	155	205	50	40	41.1
BREU100 (K) E2+E3	100	28×6.4	186	270	140	2.0	45	180	230	50	40	65.0
BREU130 (K) E2+E3	130	32×7.4	212	310	160	2.5	60	205	268	68	55	94.0
BREU150 (K) E2+E3	150	36×8.4	246	400	200	2.5	60	255	325	68	55	190.0

### Installation and Usage

1. By installing the E2 flange and E3 torque arm on the opposite side, the direction of rotation can be changed.
2. Align the key to slide through the keyway smoothly before installation.
3. When mounting the clutch onto the shaft, apply pressure to the inner race but never to the outer race. Tap the inner race lightly with a soft hammer moving around the race circumference so the Cam Clutch moves slowly and uniformly onto the end of the shaft.
4. All models are pre-greased.  
The ambient temperature range is  $-40^{\circ}\text{C}$  to  $+40^{\circ}\text{C}$ .  
Too much additional grease to both bearing inhibits the basic Cam Clutch function. Refer to page 80 for the maintenance.
5. Refer to page 59 for other general information.

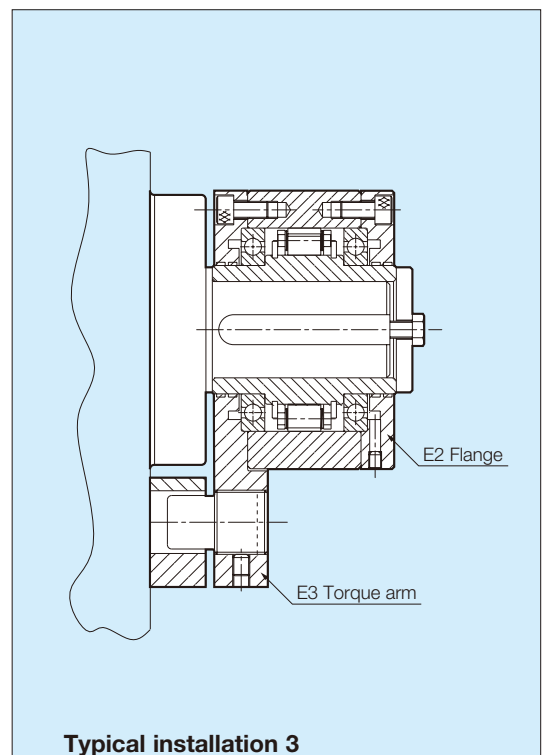

## E3 Torque arm + E4 Cover

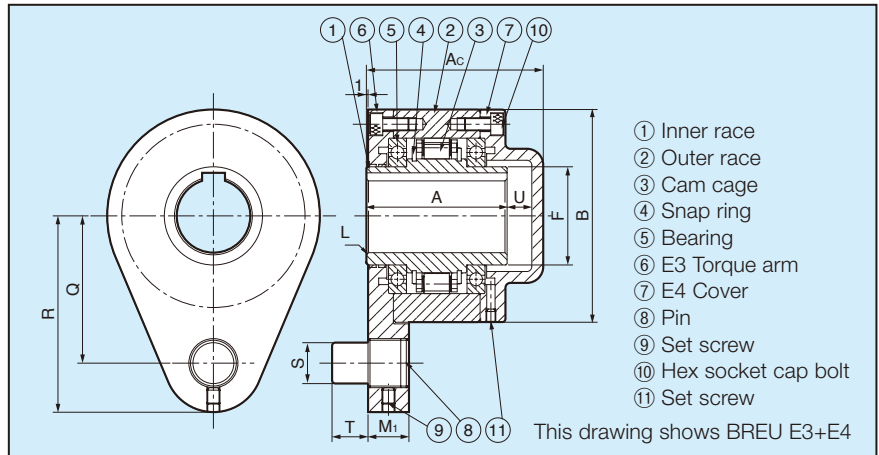
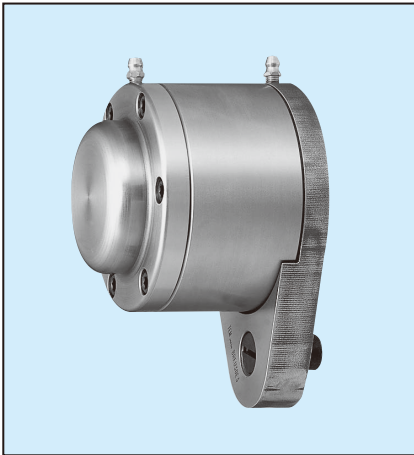

### Dimensions

Dimensions in mm

Model	Bore Size (H7)	Inner Race Keyway	A	Ac	B (h7)	F	L (C)	M <sub>1</sub>	Q	R	S	T	U	Weight (kg)
BREU 30 (K) E3+E4	30	8×3.3	76	92	100	45	1.0	19	68	92	16	14	10	4.5
BREU 35 (K) E3+E4	35	10×3.3	79	97	110	50	1.0	22	76	102	20	18	12	5.3
BREU 40 (K) E3+E4	40	12×3.3	86	105	125	55	1.3	22	85	112	20	18	12	7.4
BREU 45 (K) E3+E4	45	14×3.8	86	108	130	60	1.3	25	90	120	25	22	15	8.1
BREU 50 (K) E3+E4	50	14×3.8	94	113	150	70	1.3	25	102	135	25	22	12	11.5
BREU 55 (K) E3+E4	55	16×4.3	104	126	160	75	1.5	30	108	142	32	25	15	15.6
BREU 60 (K) E3+E4	60	18×4.4	120	143	170	80	1.5	30	112	145	32	25	15	18.0
BREU 70 (K) E3+E4	70	20×4.9	134	164.5	190	90	1.8	35	135	175	38	30	22.5	25.5
BREU 80 (K) E3+E4	80	22×5.4	144	168	210	105	1.8	35	145	185	38	30	16	32.9
BREU 90 (K) E3+E4	90	25×5.4	158	192	230	120	2.0	45	155	205	50	40	27	43.4
BREU100 (K) E3+E4	100	28×6.4	186	221	270	140	2.0	45	180	230	50	40	28	67.0
BREU130 (K) E3+E4	130	32×7.4	212	250	310	160	2.5	60	205	268	68	55	30	97.0
BREU150 (K) E3+E4	150	36×8.4	246	286	400	200	2.5	60	255	325	68	55	32	193.0

### Installation and Usage

1. By installing the E3 torque arm and E4 cover on the opposite side, the direction of rotation can be changed.
2. Align the key to slide through the keyway smoothly before installation.
3. When mounting the clutch onto the shaft, apply pressure to the inner race but never to the outer race. Tap the inner race lightly with a soft hammer moving around the race circumference so the Cam Clutch moves slowly and uniformly onto the end of the shaft.
4. All models are pre-greased.  
The ambient temperature range is  $-40^{\circ}\text{C}$  to  $+40^{\circ}\text{C}$ .  
Too much additional grease to both bearing inhibits the basic Cam Clutch function. Refer to page 80 for the maintenance.
5. Refer to page 59 for other general information.

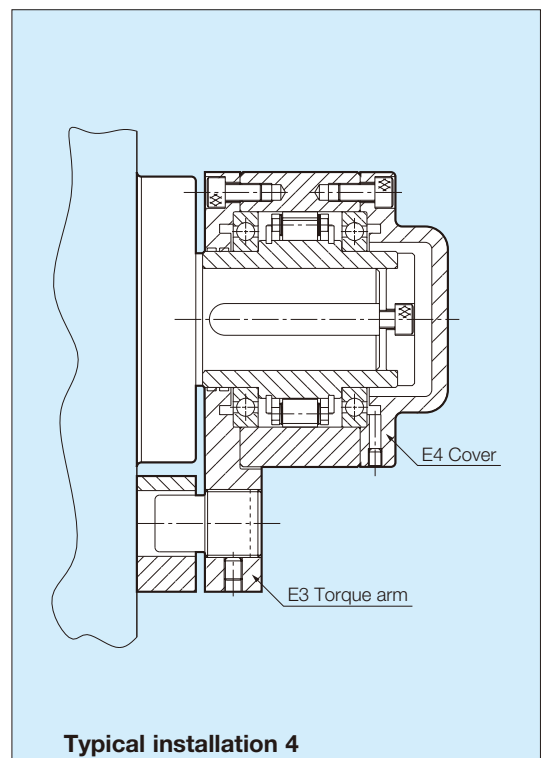

## E5 Flange + E5 Flange

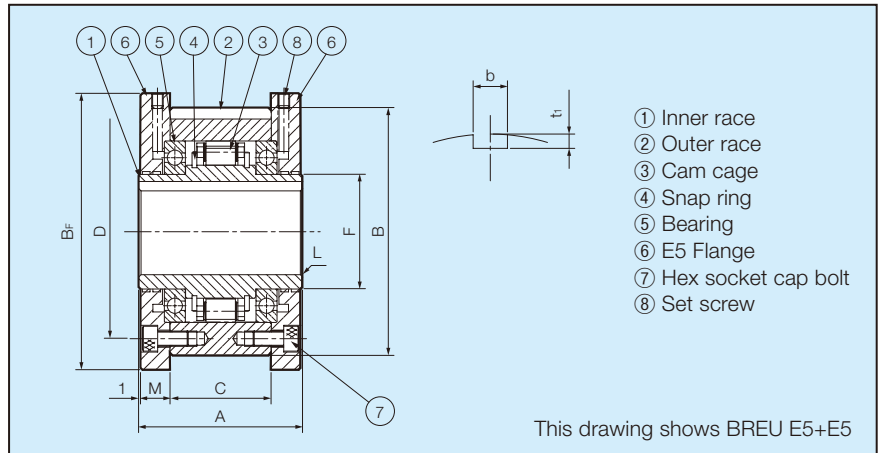
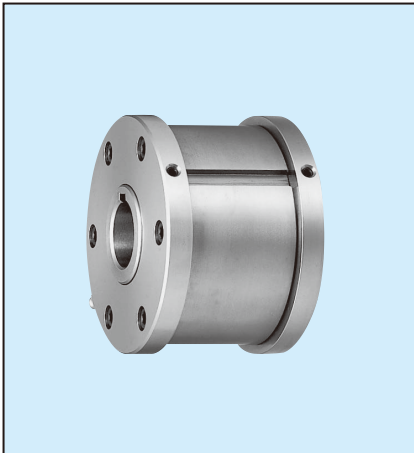

### Dimensions

Dimensions in mm

Model	Bore Size (H7)	Inner Race Keyway	A	B (h7)	Bf	C	D	F	L (C)	M	b (P10)	t <sub>1</sub>	Weight (kg)
BREU 30K E5+E5	30	8×3.3	76	100	109	51	87	45	1.0	11.5	8	4.0	3.9
BREU 35K E5+E5	35	10×3.3	79	110	119	50	96	50	1.0	13.5	10	5.0	4.9
BREU 40K E5+E5	40	12×3.3	86	125	135	53	108	55	1.3	15.5	12	5.0	7.0
BREU 45K E5+E5	45	14×3.8	86	130	140	53	112	60	1.3	15.5	14	5.5	7.4
BREU 50K E5+E5	50	14×3.8	94	150	160	64	132	70	1.3	14.0	14	5.5	10.7
BREU 55K E5+E5	55	16×4.3	104	160	170	66	138	75	1.5	18.0	16	6.0	13.6
BREU 60K E5+E5	60	18×4.4	120	170	182	84	150	80	1.5	17.0	18	7.0	17.3
BREU 70K E5+E5	70	20×4.9	134	190	202	95	165	90	1.8	18.5	20	7.5	23.5
BREU 80K E5+E5	80	22×5.4	144	210	222	100	185	105	1.8	21.0	22	9.0	31.3
BREU 90K E5+E5	90	25×5.4	158	230	242	115	206	120	2.0	20.5	25	9.0	38.4
BREU100K E5+E5	100	28×6.4	186	270	282	124	240	140	2.0	30.0	28	10.0	63.0
BREU130K E5+E5	130	32×7.4	212	310	322	152	278	160	2.5	29.0	32	11.0	88.0
BREU150K E5+E5	150	36×8.4	246	400	412	180	360	200	2.5	32.0	36	12.0	184.0

### Installation and Usage

1. By turning the Cam Clutch on the opposite side, the direction of rotation can be changed.
2. Fix the grease nipple to the option parts.
3. Align the key to slide through the keyway smoothly before installation.
4. When mounting the clutch onto the shaft, apply pressure to the inner race but never to the outer race. Tap the inner race lightly with a soft hammer moving around the race circumference so the Cam Clutch moves slowly and uniformly onto the end of the shaft.
5. All models are pre-greased.  
The ambient temperature range is  $-40^{\circ}\text{C}$  to  $+40^{\circ}\text{C}$ .  
Too much additional grease to both bearing inhibits the basic Cam Clutch function. Refer to page 80 for the maintenance.
6. Refer to page 59 for other general information.
7. E5+E5 flange is available only for BREU K model.

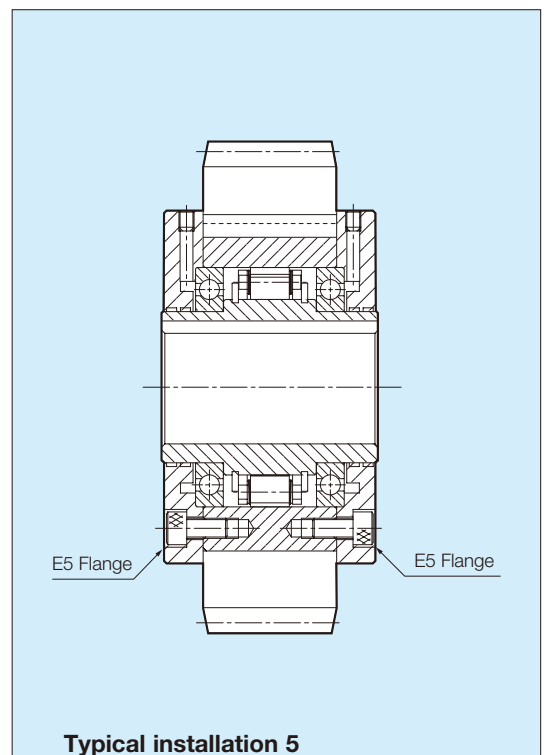

## E2 Flange + E7 Flange

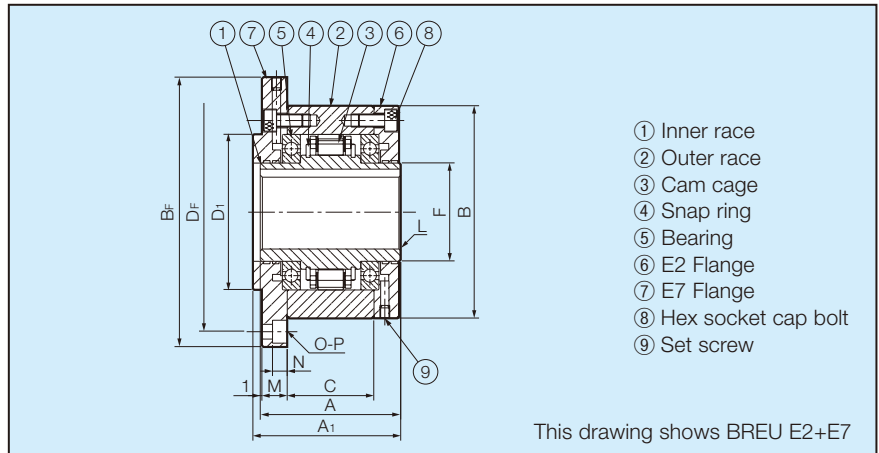
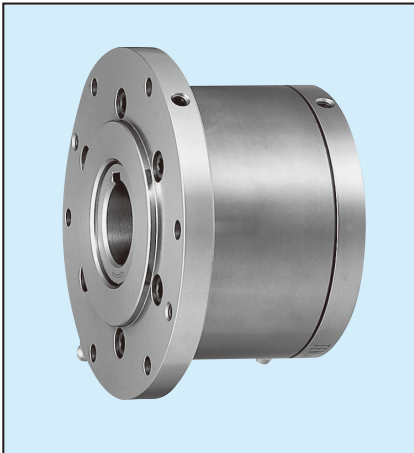

### Dimensions

Dimensions in mm

Model	Bore Size (H7)	Inner Race Keyway	A	A <sub>1</sub>	B (h7)	B <sub>F</sub>	C	D <sub>1</sub> (h7)	D <sub>F</sub>	F	L (C)	M	N	O-P	Weight (kg)
BREU 30 (K) E2+E7	30	8×3.3	76	78	100	128	51	75	114	45	1.0	11.5	6.8	6-φ6.6	4.2
BREU 35 (K) E2+E7	35	10×3.3	79	81	110	140	50	80	124	50	1.0	13.0	6.8	6-φ6.6	5.3
BREU 40 (K) E2+E7	40	12×3.3	86	88	125	160	53	90	142	55	1.3	15.0	9.0	6-φ9.0	7.6
BREU 45 (K) E2+E7	45	14×3.8	86	88	130	165	53	95	146	60	1.3	15.0	9.0	8-φ9.0	8.0
BREU 50 (K) E2+E7	50	14×3.8	94	96	150	185	64	110	166	70	1.3	13.0	9.0	8-φ9.0	11.3
BREU 55 (K) E2+E7	55	16×4.3	104	106	160	204	66	115	182	75	1.5	17.0	11.0	8-φ11.0	14.8
BREU 60 (K) E2+E7	60	18×4.4	120	122	170	214	84	125	192	80	1.5	16.0	11.0	10-φ11.0	18.2
BREU 70 (K) E2+E7	70	20×4.9	134	136	190	234	95	140	212	90	1.8	17.5	11.0	10-φ11.0	24.8
BREU 80 (K) E2+E7	80	22×5.4	144	146	210	254	100	160	232	105	1.8	20.0	11.0	10-φ11.0	32.9
BREU 90 (K) E2+E7	90	25×5.4	158	160	230	278	115	180	254	120	2.0	19.0	13.0	10-φ14.0	40.8
BEEU100 (K) E2+E7	100	28×6.4	186	188	270	335	124	210	305	140	2.0	28.0	17.5	10-φ18.0	69.0
BREU130 (K) E2+E7	130	32×7.4	212	214	310	380	152	240	345	160	2.5	27.0	17.5	12-φ18.0	96.0
BREU150 (K) E2+E7	150	36×8.4	246	248	400	485	180	310	445	200	2.5	30.0	21.5	12-φ22.0	198.0

### Installation and Usage

1. By installing the E2 flange and E7 flange on the opposite side, the direction of rotation can be changed.
2. Fix the grease nipple to the option parts.
3. Align the key to slide through the keyway smoothly before installation.
4. When mounting the clutch onto the shaft, apply pressure to the inner race but never to the outer race. Tap the inner race lightly with a soft hammer moving around the race circumference so the Cam Clutch moves slowly and uniformly onto the end of the shaft.
5. All models are pre-greased.  
The ambient temperature range is -40°C to +40°C.  
Too much additional grease to both bearing inhibits the basic Cam Clutch function. Refer to page 80 for the maintenance.
6. Too much overhang load to F7 flange also inhibits the basic Cam Clutch function. Add one more bearing to the fixed equipment on the correct center line if the overhang load is big.
7. Refer to page 59 for other general information.

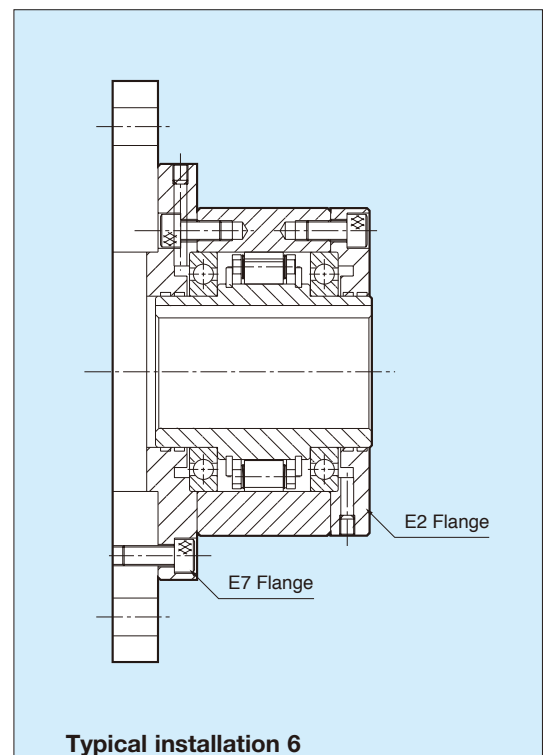

## COUPLING

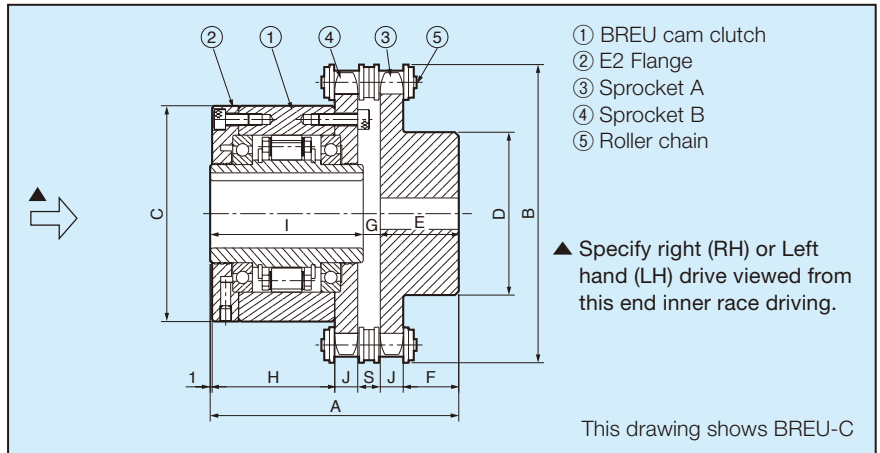
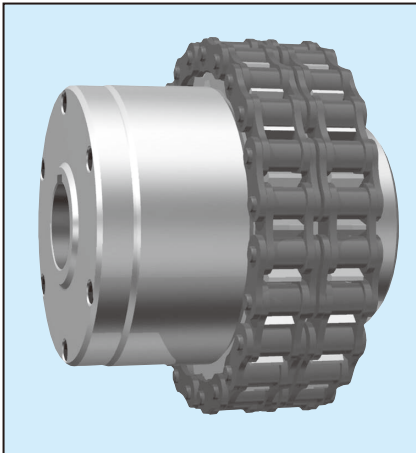

### Dimensions

Dimensions in mm

Model	Bore Size (H7)	Inner Race Keyway	A	B	C (h7)	D	E	F	G	H	I	J	S	Weight (kg)
BREU 30 (K)-C	30	8×3.3	109.9	137	100	73	28	19.3	5.9	62.5	76	8.7	9.7	5.9
BREU 35 (K)-C	35	10×3.3	127.7	152	110	83	40	28.3	8.7	63.5	79	11.7	11.5	8.5
BREU 40 (K)-C	40	12×3.3	132.7	164	125	83	40	28.3	6.7	68.5	86	11.7	11.5	10.5
BREU 45 (K)-C	45	14×3.8	132.7	176	130	83	40	28.3	6.7	68.5	86	11.7	11.5	11.2
BREU 50 (K)-C	50	14×3.8	142.2	200	150	83	40	28.3	8.2	78.0	94	11.7	11.5	15.6
BREU 55 (K)-C	55	16×4.3	159.8	219	160	107	45	30.4	10.8	84.0	104	14.6	15.2	21.8
BREU 60 (K)-C	60	18×4.4	176.8	235	170	107	45	30.4	11.8	101.0	120	14.6	15.2	26.4
BREU 70 (K)-C	70	20×4.9	189.3	251	190	107	45	30.4	10.3	113.5	134	14.6	15.2	33.0
BREU 80 (K)-C	80	22×5.4	196.8	267	210	107	45	30.4	7.8	121.0	144	14.6	15.2	41.0

### Installation and Usage

1. BREU-(K) C series Cam Clutch couplings make use of BREU series Cam Clutch and CR type couplings without cover.
2. Mount the clutch loosely on the high-speed shaft at first.
3. Accurately align both sprockets by checking with a straight edge on the teeth of both sprockets.
4. Check whether the clearance(S) between the two sprockets is correct, then wrap the chain around the sprockets.
5. Specify right hand (RH) or left hand (LH) as inner race overrunning direction from the view of cam clutch side (\*) when ordering. See the above drawing.
6. The same lubrication as for Tsubaki roller chain is necessary for the coupling chain.
7. Ensure that the chain is properly closed with a connecting link and that the closed of the spring clip is installed in the same direction as the rotation of the outer race.

# MG, MI SERIES CAM CLUTCH

## MODELS MG300 TO MG1300/MI300 TO MI1300

### For General Applications

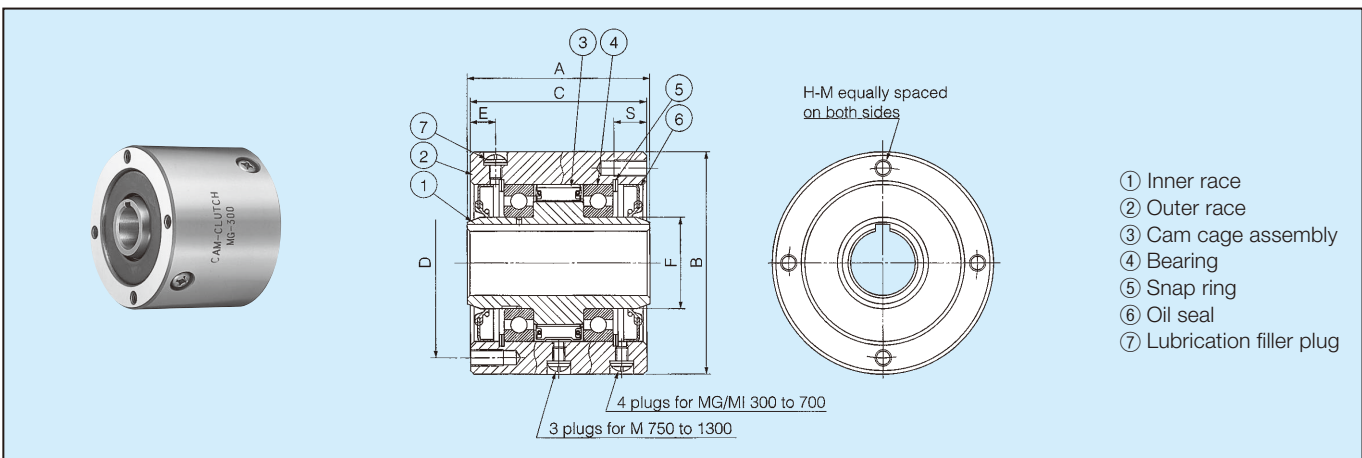

### Dimensions and Capacities

Dimensions in mm

Model	Torque Capacity (N·m)	Drag Torque (N·m)	Max. Overrunning (r/min)		Max. Indexing (cycle/min)	Bore Size		A	B (h7)	C	PCD D	E	F	S	H-M No. of Tapped Holes×Size ×Pitch	Lubrication Filler Plug Size×Pitch	Oil (ml)	Weight (kg)
			Inner Race	Outer Race		Dia. (H7)	Keyway											
MG 300 MI 300	314	0.23 0.31	2800 900	900 —	— 300	19	5× 2	63	77	60	66	10.4	28.5	13	4×M 6×P1.0	M 6×P1.0	25 50	1.8
MG 400 MI 400	539	0.29 0.38	2600 50	800 —	— 300	22	5× 2	70	88	67	73	10.7	31.7	16	4×M 8×P1.25	M 6×P1.0	30 60	2.7
MG 500 MI 500	1620	0.51 0.68	2400 50	800 —	— 300	31.5	7× 3	89	108	86	92	12.3	44.4	16	4×M 8×P1.25	M 6×P1.0	50 100	5.0
MG 600 MI 600	3140	0.85 1.54	2100 30	700 —	— 300	50	12× 3.5	95	136	92	120	12.8	69.8	16	6×M 8×P1.25	M 6×P1.0	80 160	8.6
MG 700 MI 700	5880	1.70 2.63	1500 30	500 —	— 300	70	18× 6	127	180	124	160	19.8	101.5	20	6×M10×P1.5	M 6×P1.0	135 260	19.5
MG 750 MI 750	9500	3.43 4.12	1800 30	600 —	— 300	85	24× 6	153	200	150	175	75	110	25	8×M14×P2.0	M 8×P1.25	400 800	37.0
MG 800 MI 800	17600	5.39 8.33	1300 20	475 —	— 300	110	28× 7	158	250	155	220	77.5	140	25	8×M16×P2.0	M 8×P1.25	500 1000	46.5
MG 900 MI 900	24500	6.77 9.41	1200 20	400 —	— 300	135	35× 9	165	300	160	265	80	170	32	10×M16×P2.0	M 8×P1.25	620 1240	70.5
MG1000 MI 1000	33800	8.14 12.74	1200 20	325 —	— 300	160	38×10	188	370	180	325	90	200	32	12×M16×P2.0	M 8×P1.25	850 1700	108.5
MG1100 MI 1100	78400	15.00 22.15	350 20	— 150	— 150	185	45×14	260	470	250	415	125	260	40	12×M20×P2.5	M12×P1.75	2900 5800	250
MG1200 MI 1200	95100	17.64 27.54	300 20	— 150	— 150	200	45×14	260	500	250	440	125	280	45	12×M24×P3.0	M12×P1.75	3000 6000	280
MG1300 MI 1300	176000	18.72 28.13	250 20	— 150	— 150	250	56×17.5	280	600	260	530	130	340	50	12×M30×P3.5	M12×P1.75	3800 7600	410

**Note:** If the inner race overrunning speed is above 400 r/min please consider BR-P series for long life high speed operation if application is Backstopping.

### Installation and Usage

- MG Series Cam Clutch is used for inner race overrunning applications. MI Series Cam Clutch is used for indexing applications.
- For attaching a pulley, a gear, or sprocket to the clutch, insert the clutch into the hub of the device, and screw the bolts (high tension) into the tapped holes on the clutch end. The tolerance bore of the hub should be H6 or H7 of JIS standard. See the installation illustration on page 68.
- Recommended shaft tolerances is H6 or H7.
- The key should be in accordance with JIS B1301-1959. However, for M750 and above models, a key is attached.
- Align the key to slide through the keyway smoothly before installation.
- Use only a parallel key to secure the clutch. Never use a tapered key.
- If the clutch receives shock loads or is designed for use at full torque

- capacity, it is better to use a hardened key and shaft.
- Allow for a clearance between the top of the clutch keyway and the top of the key for pressure ventilation of the clutch in the case of MG Series. A pressure ventilation hole is provided on the keyway of the clutch inner race.
- When mounting the clutch on a shaft, apply pressure to the inner race, but never to the outer race.
- Thrust load should be taken up by other devices, not by the Cam Clutch.
- When using MG Series at medium and high speeds, pay attention to heating. Life is shortened if the temperature of Cam Clutch outer race rises to over

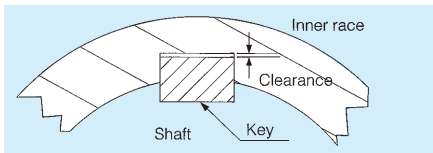

- 70°C. In case of continuous over running Please contact Tsubaki. In this case, use a different model or provide an oil bath or forced lubrication. During continuous overrunning, generally use MG Series at approximately 1/3 or less of the maximum overrunning rotation speed.
- Oil is not sealed in at the time of shipment. Supply an appropriate amount of oil before use.
- When placing an order for MG Series Cam Clutch model MG 750 and above, please inform TSUBAKI of the overrunning speed you use.
- For vertical mounting, please consult TSUBAKI.
- When using MG series at lower than 200r/min rotation speed please contact Tsubaki. The vent hole is removed to avoid oil leakage.

- See "Information for Selection" on page 77.
- See "Lubrication and Maintenance" on page 79.

# MR SERIES CAM CLUTCH

## MODELS MR 750 TO MR 1000

### Outer Race Rotation and Lift-Off Cam Type

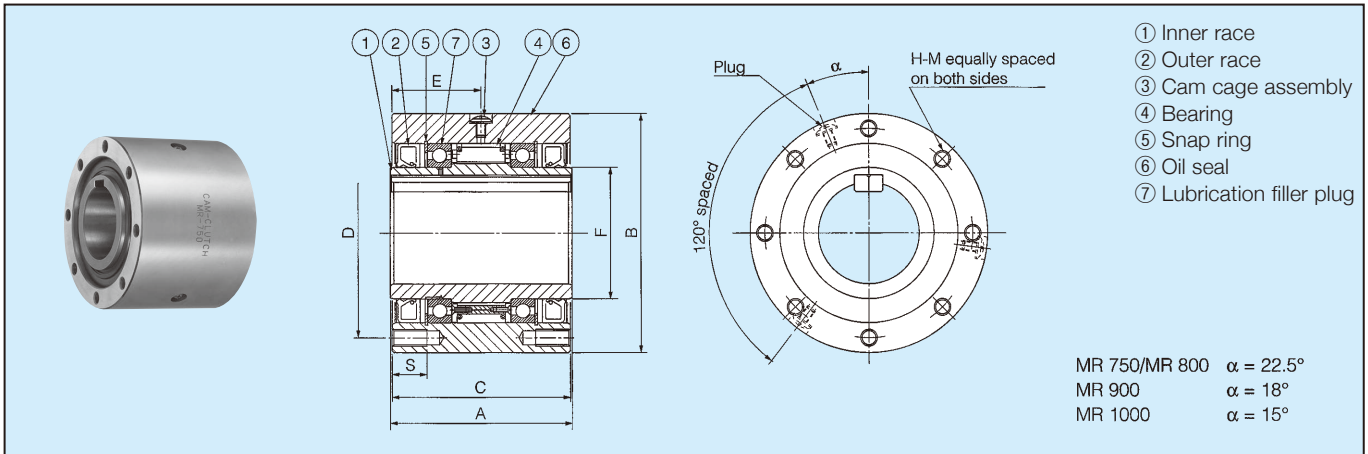

### Dimensions and Capacities

Dimensions in mm

Model	Torque Capacity (N·m)	Max. Overrunning (r/min)		Bore Size		A	B (h7)	C	PCD D	E	F	S	H-M No. of Tapped Holes×Size ×Pitch	Lubrication Filler Plug Size×Pitch	Oil (ml)	Weight (kg)
		Inner Race	Outer Race	Dia. (H7)	Keyway											
MR 750	9500	525	2600	85	24×6	153	200	150	175	75	110	25	8×M14×P2.0	M8×P1.25	400	37.0
MR 800	17600	475	2100	110	28×7	158	250	155	220	77.5	140	25	8×M16×P2.0	M8×P1.25	500	46.5
MR 900	24500	400	1850	135	35×9	165	300	160	265	80	170	32	10×M16×P2.0	M8×P1.25	620	70.5
MR1000	33800	325	1600	160	38×10	188	370	180	325	90	200	32	12×M16×P2.0	M8×P1.25	850	108.5

### Installation and Usage

- MR Series Cam Clutch is used for outer race overrun in high-speed applications.
- For attaching a pulley, a gear, or a sprocket to the clutch, insert the clutch into the hub of the said device, and screw the bolts (high tension) into the tapped holes on the clutch. The tolerance of the bore hub should be H6 or H7 of ISO R773. See the illustration on this page.
- Recommended shaft tolerances are as follows:

Model	Tolerance
MR 750, MR 800	+0 to -0.035
MR 900, MR 1000	+0 to -0.040

- When mounting the clutch on a shaft, apply pressure to the clutch inner race, but never to the outer race.
- Allow for a clearance between the top of the clutch keyway and the top of the key for pressure ventilation. A pressure ventilation hole is provided on the keyway of the clutch inner race.

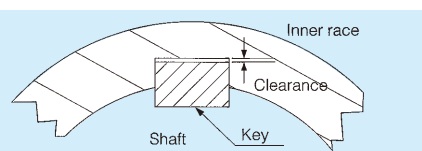

- When the clutch receives a shock load or is designed for use at full torque capacity, it is better to use it on an unannealed or hardened shaft.
- Thrust load should be taken up by other devices, not by the Cam Clutch.
- MR Series Cam Clutch includes special keys (hardened) which have a special height dimension. The depth of the key groove for the shaft should comply with ISO R773.
- Forced lubrication is recommended for continuous operation. Consult TSUBAKI regarding the method.
- Oil is not sealed in at the time of shipment. Supply an appropriate amount of oil before use.

### Typical installation MG, MI, MR Series

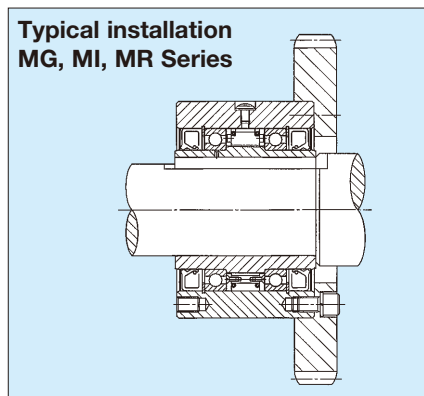

### Lift-off (Outer race rotation type)

MR Series Cam Clutch is structured so that the cam rotates together with the outer race when the outer race overruns. As shown in the figure, the spring force ( $F_s$ ) works to make the cam come in contact with the inner and outer races with fixed pressure. Conversely, the eccentric force ( $F_c$ ), which works on the cam when overrunning, applies a moment in the direction where the cam does not contact the inner and outer races. Accordingly, when the overrunning speed is increased, the eccentric force ( $F_c$ ) increases and the movement is augmented over the movement caused by the spring force. Next, the cam lifts off from the inner race and loses contact with it. This phenomenon is called "lift-off." In this state, there is no friction on the cam and it continues overrunning as long as the bearing lasts.

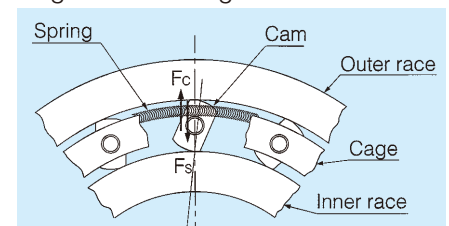

- See "Information for Selection" on page 77.
- See "Lubrication and Maintenance" on page 79.

# MG-R SERIES CAM CLUTCH

## MODELS MG 300R TO MG 1300R

For Backstop Applications with Oil Reservoir

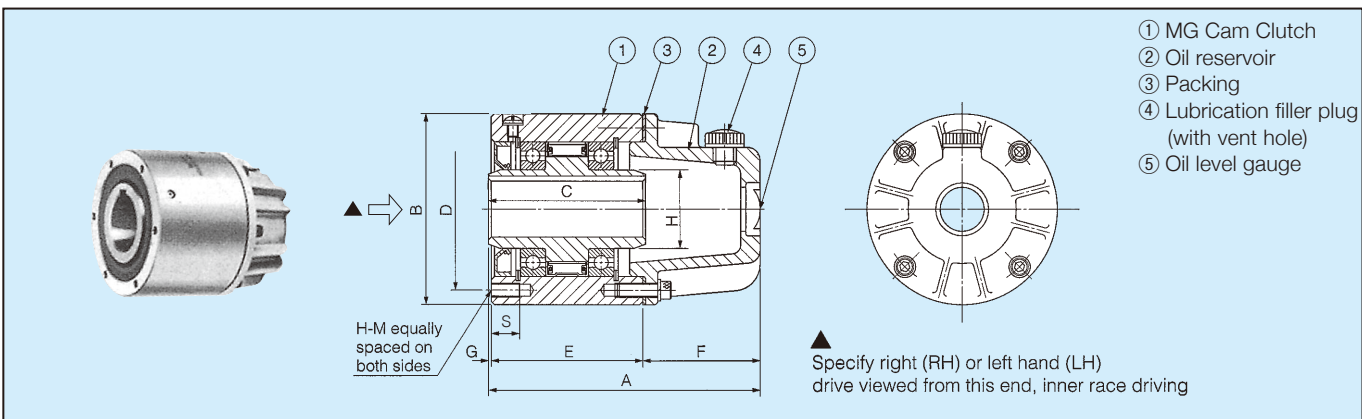

### Dimensions and Capacities

Dimensions in mm

Model	Torque Capacity (N-m)	Drag Torque (N-m)	Max. Overrunning (r/min) Inner Race	Bore Size		A	B (h7)	C	PCD D	E	F	G	H	H-M No. of Tapped Holes×Size ×Pitch	S	Weight (kg)
				Dia. (H7)	Keyway											
MG 300R	314	0.16	2800	19	5×2	115	77	63	66	60	53.5	1.5	28.5	4×M6×P1.0	13	2.0
MG 400R	539	0.20	2600	22	5×2	122	88	70	73	67	53.5	1.5	31.7	4×M8×P1.25	16	3.0
MG 500R	1620	0.36	2400	31.5	7×3	154	108	89	92	86	66.5	1.5	44.4	4×M8×P1.25	16	5.5
MG 600R	3140	0.59	2100	50	12×3.5	165	136	95	120	92	71.5	1.5	69.8	6×M8×P1.25	16	9.5
MG 700R	5880	1.19	1500	70	18×6	207	180	127	160	124	81.5	1.5	101.5	6×M10×P1.5	20	21.0
MG 750R	9500	2.75	1800	85	24×6	280	200	153	175	150	128.5	1.5	110	8×M14×P2.0	25	40.3
MG 800R	17600	4.32	1300	110	28×7	298.5	250	158	220	155	142	1.5	140	8×M16×P2.0	25	50.6
MG 900R	24500	5.39	1200	135	35×9	314.5	300	165	265	160	152	2.5	170	10×M16×P2.0	32	77.6
MG1000R	33800	6.47	1200	160	38×10	341	370	188	325	180	157	4.0	200	12×M16×P2.0	32	116.6
MG1100R	78400	12.74	350	185	45×14	400	470	260	415	250	140	5.0	260	12×M20×P2.5	40	275
MG1200R	95100	15.29	300	200	45×14	439	500	318	440	300	130	9.0	280	12×M24×P3.0	45	320
MG1300R	176000	15.98	250	250	56×17.5	470	600	340	530	320	140	10.0	340	12×M30×P3.5	50	480

### Installation and Usage

- MG-R Series Cam Clutch consists of MG Series Cam Clutch and oil reservoir. See "Installation and Usage" on page 67 for MG series clutch.
- These clutches are used for backstop applications.
- Specify right hand (RH) or left hand (LH) drive of inner race viewed from the end marked with the arrow.
- Prevent oil leakage from the shaft end by using an end plate with packing and sealed washers. Refer to the installation drawing on the right.
- Align the key to slide through the keyway smoothly before installation.
- When attaching an oil reservoir, be sure to put packing in between the Cam Clutch end and oil reservoir. Position one of the plugs of the Cam Clutch underneath as a drain and the oil reservoir plug directly above it.
- In case of continuous over running Please consult Tsubaki.

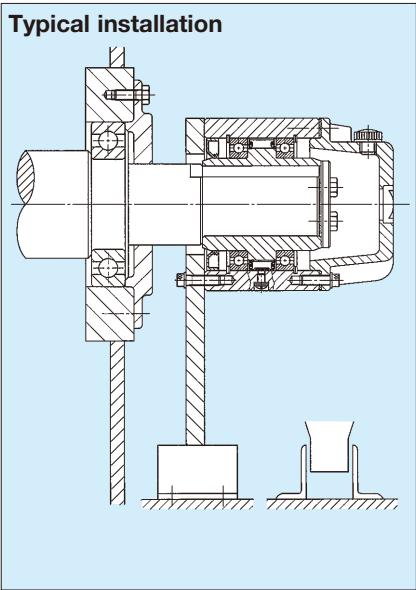

### Dimensions for End Plate and Packing

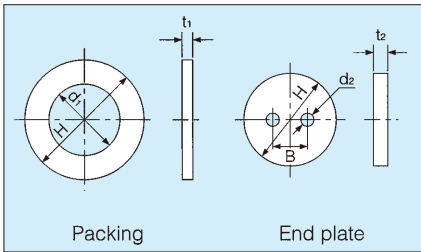

Dimensions in mm

Model	Packing			End plate				
	H	d <sub>1</sub>	t <sub>1</sub>	H	t <sub>2</sub>	B	d <sub>2</sub>	Bolt Size
MG 300R	28	19	1.5	28	4	11	5.5	M 5
MG 400R	31	22	1.5	31	4	13	6.6	M 6
MG 500R	44	31.5	1.5	44	6	20	9	M 8
MG 600R	69	50	1.5	69	8	30	11	M10
MG 700R	101	70	1.5	101	8	40	14	M12
MG 750R	110	85	1.5	110	10	50	18	M16
MG 800R	140	110	1.5	140	10	70	18	M16
MG 900R	170	135	1.5	170	10	80	18	M16
MG1000R	200	160	1.5	200	10	100	18	M16
MG1100R	245	185	2.0	245	15	110	22	M20
MG1200R	265	200	2.0	265	15	120	22	M20
MG1300R	325	250	2.0	325	15	150	22	M20

The above packing and end plate are to be prepared by the customer.

- See "Information for Selection" on page 77.
- See "Lubrication and Maintenance" on page 79.

# MZ-C, MG-C SERIES CAM CLUTCH

## MODELS MZ20C TO MZ70C AND MG300C TO MG1000C

### For Coupling Applications

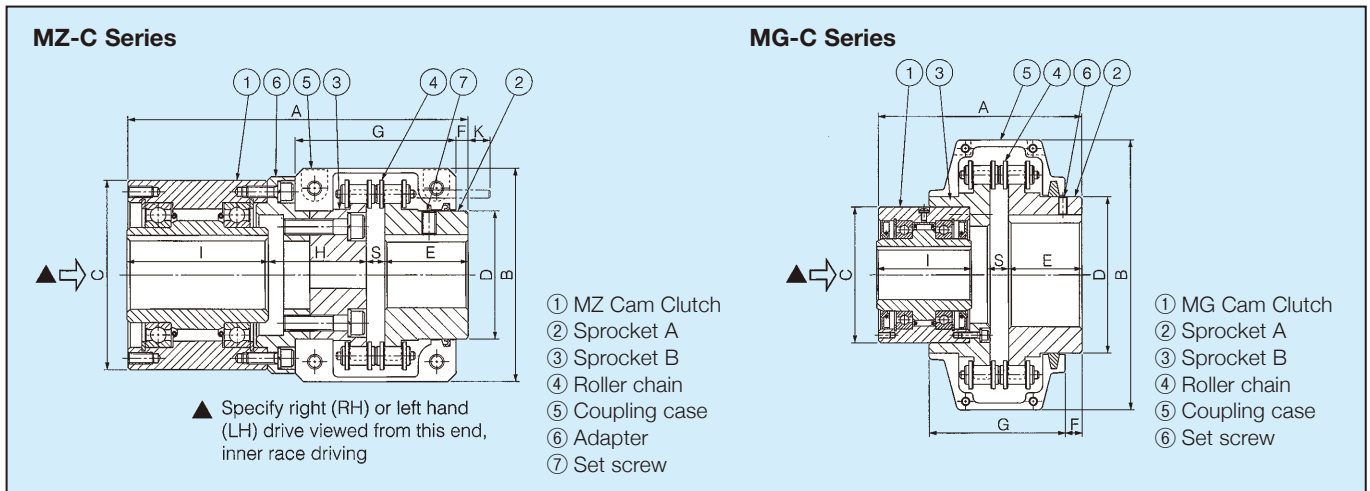

### Dimensions and Capacities

Dimensions in mm

Model	Torque Capacity (N·m)	Drag Torque (N·m)	Max.Overrunning (r/min)		Clutch Side Bore Size		Coupling Side Bore Size Range		A	B (h7)	C	D	E	F	G	H	I	K	S	Weight (kg)
			Inner Race	Outer Race	Dia. (H7)	Keyway	Min.	Max.												
MZ 20C	323	0.29	1900	700	20	6×2.8	15	40	174	111	80	60	45	7.35	85	52.3	67	12	9.7	6.1
MZ 30C	735	0.39	1800	500	30	10×3.3	15	45	194	122	100	70	45	7.35	85	57.3	82	12	9.7	9.4
MZ 45C	1620	0.69	1700	300	45	14×3.8	20	65	226	142	125	85	56	8.7	106	66.5	92	15	11.5	15.8
MZ 60C	2110	0.98	1600	250	60	18×4.4	20	75	236	167	155	110	56	8.7	106	66.5	102	15	11.5	24.5
MZ 70C	3040	1.27	1300	250	70	20×4.9	25	80	260	186	175	115	63	5.6	130	76.8	105	30	15.2	32.6

### Installation and Usage

- MZ-C Series Cam Clutch is clutch coupling utilizing MZ Series Cam Clutch. Refer to "Installation and Usage" on page 22 for the MZ Series Cam Clutches.
- First mount the clutch loosely on the high-speed shaft.
- Accurately align both sprockets by checking with a straight edge on the teeth of both sprockets. Check if the clearance (S) between the two sprockets is correct and then wrap the chain around the sprockets.
- Specify right hand (RH) or left hand (LH) inner race drive when ordering. See the drawing above.
- The same lubrication as for TSUBAKI Roller Chain is necessary for the coupling chain.

### Dimensions and Capacities

Dimensions in mm

Model	Torque Capacity (N·m)	Drag Torque (N·m)	Max.Overrunning (r/min)		Clutch Side Bore Size		Coupling Side Bore Size Range		A	B	C (h7)	D	E	F	G	S	I	Weight (kg)
			Inner Race	Outer Race	Dia. (H7)	Keyway	Min.	Max.										
MG 300C	314	0.23	2800	900	19	5×2	20	56	155	142	77	85	56	8.7	106	11.5	63	8.5
MG 400C	539	0.29	2600	800	22	5×2	20	75	160	167	88	110	56	8.7	106	11.5	70	13.5
MG 500C	1620	0.51	2400	800	31.5	7×2	30	100	195	220	108	140	71	13.55	130	15.2	89	28
MG 600C	3140	0.85	2100	700	50	12×3.5	45	125	250	307	136	170	90	14.8	181	22.7	95	52
MG 700C	5880	1.70	1500	500	70	18×6	55	150	275	357	180	210	100	24.8	181	22.7	127	80
MG 750C	9500	3.43	1800	600	85	24×6	60	160	340	406	200	224	112	2.1	250	30.1	153	147
MG 800C	17600	5.39	1300	475	110	28×7	75	200	370	472	250	280	140	30	250	30.1	158	182
MG 900C	24500	6.77	1200	400	135	35×9	98	260	496	578	300	374	241	121.7	280	37.5	165	420
MG1000C	33800	8.14	1200	325	160	38×10	108	285	510	—	370	408	241	—	—	37.5	188	470

### Installation and Usage

- MG-C Series Cam Clutch is clutch coupling utilizing MG Series Cam Clutch. Refer to "Installation and Usage" of MG Series Cam Clutch on page 67.
- Align the key to slide through the keyway smoothly before installation.
- First mount the clutch loosely on the high-speed shaft.
- Accurately align both sprockets by checking with a straight edge on the teeth of both sprockets. Check if the clearance (S) between the two sprockets is correct, then wrap the chain around the sprockets.
- Specify right hand (RH) or left hand (LH) inner race drive when ordering. See the drawing above.
- The same lubrication as for TSUBAKI Roller Chain is necessary for the coupling chain.

# CAM CLUTCH BOX (high-speed continuous running applications)

The Cam Clutch Box Series is a Cam Clutch designed within a case that uses an ideal lubrication method to enable continuous high-speed operation. Cam Clutch Boxes are available in seven different types consisting of different combinations of lubrication systems, cooling systems, and auxiliary reducers.

**TSUBAKI offers a wide variety of series to meet every customer's need.**

MODEL	LUBRICATION SYSTEM	SEALING	APPLICATION
OB-ON	Oil bath	Oil seal	High speed overrunning / High-speed, low-mid speed engaged
OB-OF	Oil bath (Water cooled)	Oil seal	High speed overrunning / High-speed, low-mid speed engaged

Economical models using oil seals and oil bath system. The oil leak detectors can be added as an option to quickly detect oil leaks from the oil seal. The OB-OF model is cooled by water, which enables high speed operation.

MODEL	LUBRICATION SYSTEM	SEALING	APPLICATION
OB-PN	Screw pump and oil bath	Oil flinger and labyrinth seal	High speed overrunning / Low-mid speed engaged
OB-PF	Screw pump and oil bath (Water cooled)	Oil flinger and labyrinth seal	High speed overrunning / Low-mid speed engaged
OB-SN	Screw pump and impeller	Oil flinger and labyrinth seal	High speed overrunning / High-speed engaged
OB-SF	Screw pump and impeller (Water cooled)	Oil flinger and labyrinth seal	High speed overrunning / High-speed engaged
OB-S	Forced lubrication	Oil flinger and labyrinth seal	High speed overrunning / High-speed engaged

These models are designed to eliminate oil leaks by adopting TSUBAKI's original "labyrinth" technique using oil flingers. Ideal for high-speed equipment operated continuously for 24 hours. The OB-PF and OB-SF models are cooled by water, which enables high speed operation.

MODEL	LUBRICATION SYSTEM	SEALING	APPLICATION
TB	Screw pump and oil bath	Oil flinger and labyrinth seal	High speed overrunning / Low-speed engaged

Combines Cam Clutch and TSUBAKI's highly-reliable worm gear reducer as an auxiliary reducer into a compact unit for turning and inching applications.

## Options

### 1 ) Brake

Prevents the input shaft from corotating due to the drag torque of the Cam Clutch when the driven and driving units are disengaged during repair or inspection.

Not provided as a standard item. A brake can be added upon request to sizes over OB100 except for the OB-ON series.

### 2 ) Oil leak detector (OB-ON and OB-OF only)

Depending on customer's requirement, quickly detects oil leaks from the oil seal to prevent external spread.

### 3 ) Echt-Flex coupling hubs

If you plan to use TSUBAKI's Echt-Flex coupling, we will complete necessary processing such as shaft bores and keyways on coupling hubs and attach them to the input and output shafts of the Cam Clutch Box before shipment.

Please provide us with the desired hub dimensions when placing an order. Single-type of disk couplings such as Echt-Flex couplings cannot absorb parallel misalignment and axial displacement. Please use the spacer type as necessary.

### 4 ) Paint

Our standard paint is for indoor use (Finish coat thickness 15µm, color munsell scale 10b 4/1.5 of acrylic lacquer painted only once). Please contact TSUBAKI when special paint is required.

## Installation and Usage

### 1. Allowable Oil Temperature

The oil temperature during continuous operation should not exceed 70°C. If the oil temperature exceeds this limit for an extended period, the oil quality will quickly deteriorate, and continued use may cause problems. Use an oil thermometer to check the oil temperature.

### 2. Replacement of Lubricant

Oil should be changed after the test run and before operation, and then at an interval of six months or one year. Do not run the Cam Clutch Box while changing the oil. Drain the old oil, use flushing oil to clean the inside of the box. Next pour new oil into the box. It is preferable to determine oil change interval by sampling and checking oil inside once a month, in case of operation in non-optimal environment.

### 3. Overhaul

We recommend regular overhauls of the Cam Clutch Box. For further details, contact TSUBAKI.

\* As OB-ON and OB-OF, oil seals are perishable it is recommended to keep spare oil seals in stock.

### 4. Thrust Load

If thrust load is generated such as shaft elongation, absorb it with a coupling so that it is not applied to the clutch.

### 5. Foundation

Recommended installation for Cam Clutch Box is mounted on a sufficiently solid foundation or fixed in line with surrounding associated components. Flexible coupling is recommended. Please avoid O.H.L. acting on input and output shaft.

### 6. Center Alignment

Misalignment causes abnormal noise, vibration, and extreme temperature increases, all of which may damage the Cam Clutch Box. The allowable misalignment is within 3/100mm, in parallel for a normal coupling. Therefore, adjust and align the relative shafts so that

their misalignment is within this range, and then check the alignment again after the installation bolts of the base are tightened. For disk, diaphragm, and other couplings where a reaction force acts, note that the misalignment allowed for the coupling itself differs from the mounting alignment accuracy required by the Cam Clutch Box.

### 7. Handling of Brake (For Drag)

The brake's purpose is to prevent the input shaft of the Cam Clutch Box from rotating due to the drag force of the output shaft rotation during maintenance. When separating the drive machine from the Cam Clutch Box, the input shaft of the Cam Clutch Box may be rotated by the drag force from the output shaft rotation, since the driven machine that is connected to the output shaft is still running. Only in this situation, use the brake to stop the rotation of the input shaft caused by the drag force. Do not use the brake to stop the drive machine or the driven machine. In addition, during normal operation, do not use the brake to stop a drive machine that is inoperative and hence is rotated by the drag force. Do not use the brake when the input shaft is rotating. Do not rotate the input shaft when the brake is used. Forcing the input shaft to rotate when the brake is used will cause wear to the brake shoe, which will cause damage to the Cam Clutch Box. Before operation, check that the brake lever on the Cam Clutch Box is set to the "Free" position. Use the brake only when the input shaft is not rotating and when the coupling is disconnected to allow for repairs to or inspections of the drive machine. Use the brake before disconnecting the coupling on the shafts, and then set the brake lever to the "Locked" position. The drive machine may be rotated by the drag force from the rotation of the driven machine. In this situation, stop this drag rotation by some means before using the brake.

### 8. About Servomotors

Do not use servomotors with the Cam Clutch drive. Doing so may cause abnormal wear on the cam.

## MODELS OB-ON

### For Continuous High-speed Overrunning

#### Features

OB-ON series use oil seal and apply oil bath system.

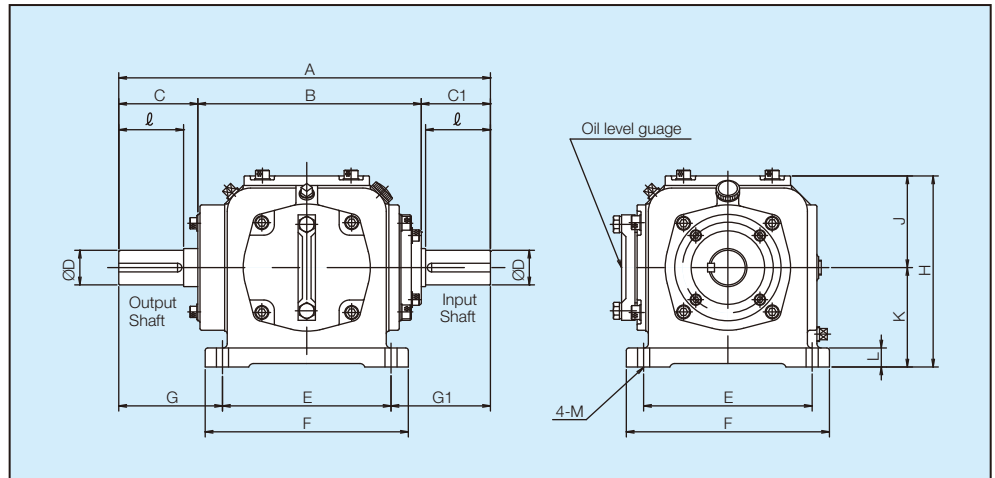

#### Dimensions and Capacities

Dimensions in mm

Model	Torque Capacity (N·m)	Max. Overrunning (r/min) Output shaft	Max. Engaging (r/min)	A	B	C	C1	E	F	G	G1	H	J	K	L	M	N	P	Q	R	S	ℓ	D (m6)	Key	Mass (kg)	Oil (L)
OB 60-ON	314	0~3000	0~1800	300	200	55	45	152	190	77	71	174	84	90	20	14	-	-	-	-	-	40	25	8x7x34 ℓ	15	1
OB100-ON	1620	0~2500	0~1800	430	258.5	91.5	80	195	235	120	115	221	106	115	22	14	-	-	-	-	-	75	40	12x8x67 ℓ	45	2
OB120-ON	3140	0~1800	0~1500	605	355	130	120	290	340	160	155	328.5	153.5	175	32	21	-	-	-	-	-	115	50	14x9x106 ℓ	90	7
OB140-ON	5880	0~1500	0~1000	670	400	140	130	330	390	175	165	368.5	168.5	200	40	25	-	-	-	-	-	125	60	18x11x114 ℓ	150	10

**Note:** After you place an order, contact us to request a drawing for your approval.

## MODELS OB-OF

### For Continuous High-speed Overrunning

#### Features

Water cooling piping is added to the ON series to suppress oil temperature rise. OB-OF series apply water cooling system and please supply cold water (less than 35°C) through the cooling pipe. The cooling pipe is made of copper and please do not use sea water. If you request special specification, please contact TSUBAKI. OB-OF series can be used for higher speed applications compared with the ON series.

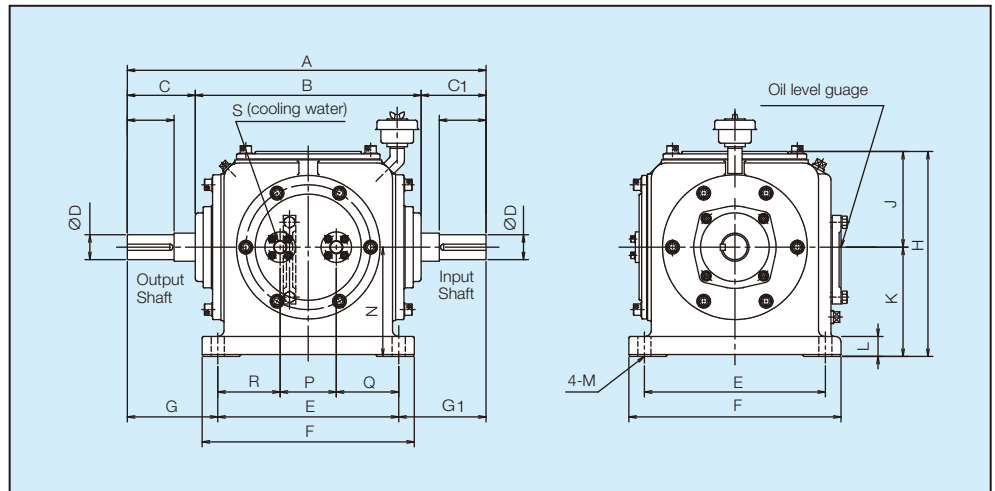

#### Dimensions and Capacities

Dimensions in mm

Model	Torque Capacity (N·m)	Max. Overrunning (r/min) Output shaft	Max. Engaging (r/min)	A	B	C	C1	E	F	G	G1	H	J	K	L	M	N	P	Q	R	S	ℓ	D (m6)	Key	Mass (kg)	Oil (L)	Cooling Water (L/min)
OB 60-OF	314	0~3600	0~3600	360	258.5	56.5	45	195	235	85	80	221	106	115	22	14	130	75	60	60	Rc3/8	40	25	8x7x34 ℓ	21	2	3
OB100-OF	1620	0~3600	0~3600	538	360	89	89	290	340	124	124	328.5	153.5	175	32	19	86.5	110	90	90	Rc1/2	75	40	12x8x67 ℓ	90	7	3
OB120-OF	3140	0~3600	0~3600	644	355	147	142	290	340	177	177	328.5	153.5	175	32	19	86.5	110	90	90	Rc1/2	115	50	14x9x106 ℓ	90	7	3
OB140-OF	5880	0~3000	0~2000	670	400	140	130	330	390	175	165	368.5	168.5	200	40	25	220	140	95	95	Rc1/2	125	60	18x11x114 ℓ	150	10	3

**Note:** After you place an order, contact us to request a drawing for your approval.

## MODELS OB-SN

### For Continuous High-speed Overrunning and Engaging

#### Features

Uses a self-lubrication method with impeller and screw pump to lubricate each required part from an oil bath with its oil level set lower than the shaft center through shaft rotation. Oil seal is not used, which eliminates oil leakage during operation.

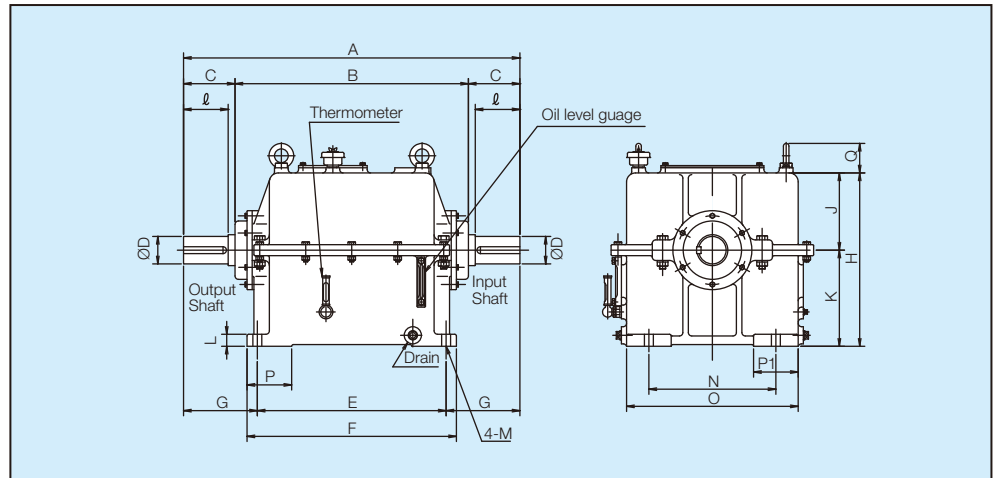

#### Dimensions and Capacities

Dimensions in mm

Model	Torque Capacity (N·m)	Max. Overrunning (r/min) Output shaft	Max. Engaging (r/min)	A	B	C	E	F	G	H	J	K	L	M	N	O	P	P1	Q	R	S	T	U	V	ℓ	D (m $\bar{g}$ )	Key	Mass (kg)	Oil (L)
OB 120-SN	3140	500-3000	500-3000	770	570	100	440	500	165	380	180	200	30	24	270	370	100	100	66	-	-	-	-	-	80	60	18x11x66 ℓ	190	12
OB 140-SN	5880	500-2400	500-2400	800	570	115	440	500	180	380	180	200	30	24	270	370	100	100	66	-	-	-	-	-	110	70	20x12x95 ℓ	210	12
OB 150-SN	9500	500-2000	500-2000	980	680	150	550	610	215	505	225	280	35	26	370	500	130	130	86	-	-	-	-	-	130	80	22x14x114 ℓ	480	30
OB 160-SN	17600	500-1500	500-1500	1070	750	160	610	670	230	550	250	300	40	28	400	550	150	185	86	-	-	-	-	-	140	100	28x16x121 ℓ	630	35

**Note:** After you place an order, contact us to request a drawing for your approval.

## MODELS OB-SF

### For Continuous High-speed Overrunning and Engaging

#### Features

Water cooling piping is added to the SN series to suppress oil temperature rise. OB-SF series apply water cooling system and please supply cold water (less than 35°C) through the cooling pipe. The cooling pipe is made of copper and please do not use sea water. If you request special specification, please contact to TSUBAKI. OB-SF series can be used for higher speed applications compared with the SN series.

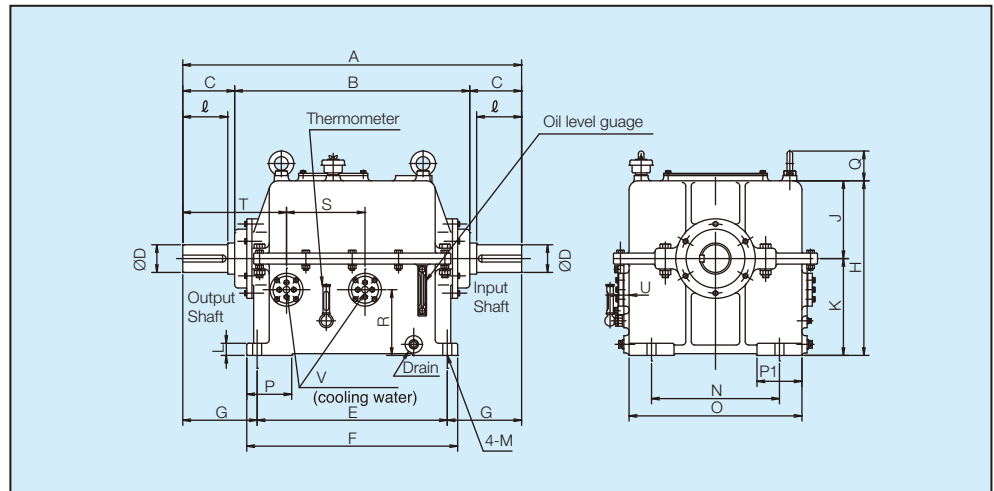

#### Dimensions and Capacities

Dimensions in mm

Model	Torque Capacity (N·m)	Max. Overrunning (r/min) Output shaft	Max. Engaging (r/min)	A	B	C	E	F	G	H	J	K	L	M	N	O	P	P1	Q	R	S	T	U	V	ℓ	D (m $\bar{g}$ )	Key	Mass (kg)	Oil (L)	Cooling Water (L/min)
OB 120-SF	3140	500-3150	500-3150	880	680	100	550	610	165	505	225	280	35	26	370	500	130	130	86	190	227	250	30	Rc1/2	80	60	18x11x66 ℓ	460	30	10
OB 140-SF	5880	500-3000	500-3000	940	680	130	550	610	195	505	225	280	35	26	370	500	130	130	86	190	227	280	30	Rc1/2	110	70	20x12x95 ℓ	480	30	10
OB 150-SF	9500	500-2400	500-2400	980	680	150	550	610	215	505	225	280	35	26	370	500	130	130	86	190	227	300	30	Rc1/2	130	80	22x14x114 ℓ	500	30	10
OB 160-SF	17600	500-1800	500-1800	1070	750	160	610	670	230	550	250	300	40	28	400	550	150	185	86	190	227	326	30	Rc1/2	140	100	28x16x121 ℓ	650	35	10
OB 180-SF	24500	400-1500	400-1500	1160	800	180	660	730	250	655	300	355	45	32	450	610	180	205	105	255	265	349	30	Rc1/2	160	120	32x18x139 ℓ	800	45	10
OB 200-SF	40180	400-1200	400-1200	1620	1000	310	840	910	390	700	320	380	45	33	550	710	85	-	105	245	265	610	30	Rc1/2	290	155	40x22x265 ℓ	1190	71	12
OB 200W-SF	80360	400-1000	400-1000	1620	1000	310	840	910	390	700	320	380	45	33	550	710	85	-	105	245	265	610	30	Rc1/2	290	155	40x22x265 ℓ	1240	71	12

**Note:** After you place an order, contact us to request a drawing for your approval.

## MODELS OB-PN

### For High-speed Overrunning and Medium and Low-speed Engaging

#### Features

Uses a self-lubrication method with a screw pump to lubricate each required part from an oil bath with its oil level set lower than the shaft center through shaft rotation. Oil seal is not used, which eliminates oil leakage during operation.

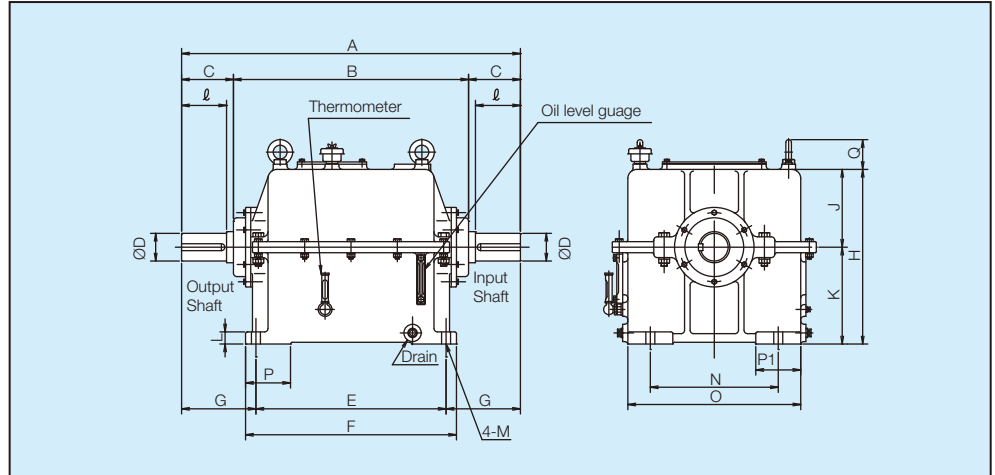

#### Dimensions and Capacities

Dimensions in mm

Model	Torque Capacity (N·m)	Max. Overrunning (r/min) Output shaft	Max. Engaging (r/min)	A	B	C	E	F	G	H	J	K	L	M	N	O	P	P1	Q	R	S	T	U	V	ℓ	D (m6)	Key	Mass (kg)	Oil (L)	
OB 120-PN	3140	0~1800	0~600	770	570	100	440	500	165	380	180	200	30	24	270	370	100	100	66	-	-	-	-	-	-	80	60	18x11x66 ℓ	180	14.5
OB 140-PN	5880	0~1800	0~600	830	570	130	440	500	195	380	180	200	30	24	270	370	100	100	66	-	-	-	-	-	110	70	20x12x95 ℓ	200	15	
OB 150-PN	9500	0~1800	0~600	910	570	170	440	500	235	380	180	200	30	24	270	370	100	100	66	-	-	-	-	-	150	70	20x12x135 ℓ	250	15	
OB 160-PN	17600	0~1500	0~500	1060	680	190	550	610	255	505	225	280	35	26	370	500	130	130	86	-	-	-	-	-	170	85	22x14x154 ℓ	400	40	
OB 180-PN	24500	0~1200	0~400	1150	750	200	610	670	270	550	250	300	40	28	400	550	150	185	86	-	-	-	-	-	180	100	28x16x161 ℓ	550	50	
OB 200-PN	40180	0~1000	0~300	1170	750	210	630	700	270	600	250	350	45	32	410	550	200	200	110	-	-	-	-	-	190	130	32x18x169 ℓ	700	60	
OB 200W-PN	80360	0~1000	0~300	1170	750	210	630	700	270	600	250	350	45	32	410	550	200	200	110	-	-	-	-	-	190	130	32x18x169 ℓ	750	60	

Note: After you place an order, contact us to request a drawing for your approval.

## MODELS OB-PF

### For High-speed Overrunning and Medium and Low-speed Engaging

#### Features

Water cooling piping is added to the PN series to suppress oil temperature rise. OB-PF series apply water cooling system and please supply cold water (less than 35°C ) through the cooling pipe. The cooling pipe is made of copper and please do not use sea water. If you request special specification, please contact to TSUBAKI. OB-PF series can be used for higher speed applications compared with the PN series.

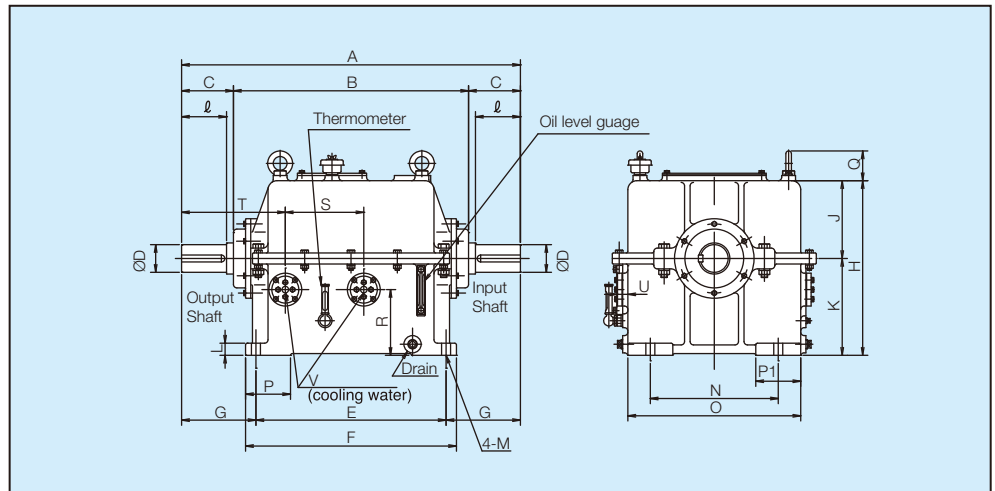

#### Dimensions and Capacities

Dimensions in mm

Model	Torque Capacity (N·m)	Max. Overrunning (r/min) Output shaft	Max. Engaging (r/min)	A	B	C	E	F	G	H	J	K	L	M	N	O	P	P1	Q	R	S	T	U	V	ℓ	D (m6)	Key	Mass (kg)	Oil (L)	Cooling Water (L/min)
OB 120-PF	3140	0~2000	0~700	880	680	100	550	610	165	505	225	280	35	26	370	500	130	130	86	190	227	250	30	Rc1/2	80	60	18x11x66 ℓ	450	40	10
OB 140-PF	5880	0~2000	0~700	940	680	130	550	610	195	505	225	280	35	26	370	500	130	130	86	190	227	280	30	Rc1/2	110	70	20x12x95 ℓ	470	40	10
OB 150-PF	9500	0~2000	0~700	980	680	150	550	610	215	505	225	280	35	26	370	500	130	130	86	190	227	300	30	Rc1/2	130	80	22x14x114 ℓ	490	40	10
OB 160-PF	17600	0~1800	0~600	1060	680	190	550	610	255	505	225	280	35	26	370	500	130	130	86	190	227	340	30	Rc1/2	170	85	22x14x154 ℓ	630	45	10
OB 180-PF	24500	0~1500	0~500	1160	800	180	660	730	250	655	300	355	45	32	450	610	79	-	105	255	265	349	30	Rc1/2	160	120	32x18x139 ℓ	770	55	10
OB 200-PF	40180	0~1200	0~400	1170	750	210	630	700	290	600	250	350	45	32	410	550	94	-	105	215	227	384	30	Rc1/2	190	130	32x18x169 ℓ	850	60	12
OB 200W-PF	80360	0~1200	0~400	1170	750	210	630	700	290	600	250	350	45	32	410	550	94	-	105	215	227	384	30	Rc1/2	190	130	32x18x169 ℓ	900	60	12

Note: After you place an order, contact us to request a drawing for your approval.

## MODELS OB-S

### For Continuous High-speed Overrunning and Engaging

#### Features

OB-S series apply forced lubrication system for each required parts such as bearings and Cam Clutch to enable operation in a wide range from low to high speed. Please prepare oil supply system and supply oil (less than 35°C) through OB-S series. If oil temperature is higher than it. For further details please contact to TSUBAKI. Oil seal is not used, which eliminates oil leakage during operation.

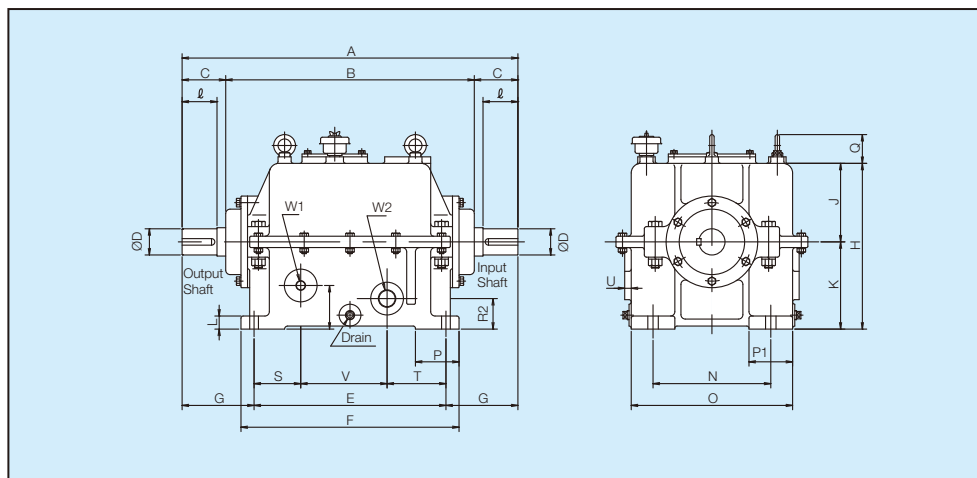

#### Dimensions and Capacities

Dimensions in mm

Model	Torque Capacity (N·m)	Max. Overrunning (r/min) Output shaft	Max. Engaging (r/min)	A	B	C	E	F	G	H	J	K	L	M	N	O	P	P1	Q	R1	R2	S	T	U	V	W1	W2	Ø	D (mm)	Key	Mass (kg)	Oil (L)
OB 120-S	3140	0~3600	0~3600	770	570	100	440	500	165	380	180	200	30	24	270	370	100	100	66	100	70	107	145	15	188	Rc1/2	Rc1/4	80	60	18x11x66 Ø	320	10
OB 140-S	5880	0~3600	0~3600	840	580	130	370	470	235	410	180	230	25	20	390	440	—	60	66	100	100	60	75	—	235	Rc1/2	Rc1/2	110	70	20x12x95 Ø	400	10
OB 150-S	9500	0~3600	0~3600	920	620	150	390	510	265	455	225	230	30	24	430	480	—	60	66	130	85	75	90	—	225	Rc1/2	Rc1/2	130	80	22x14x114 Ø	450	20
OB 160-S	17600	0~3000	0~3000	1070	750	160	610	670	230	550	250	300	40	28	400	550	150	185	86	190	75	323	450	—	163	Rc3/4	Rc1/2	140	100	28x16x121 Ø	650	20
OB 180-S	24500	0~2000	0~2000	1200	800	200	660	730	270	655	300	355	45	32	450	610	79	—	105	255	110	260	250	—	150	Rc3/4	Rc3/8	170	120	32x18x149 Ø	800	20

**Note:** After you place an order, contact us to request a drawing for your approval.

## Reference Echt-Flex coupling for Cam Clutch Box

Model	Torque Capacity (N·m)
OB 60-ON	314
OB100-ON	1620
OB120-ON	3140
OB140-ON	5880
OB 60-OF	314
OB100-OF	1620
OB120-OF	3140
OB140-OF	5880
OB 120-SN	3140
OB 140-SN	5880
OB 150-SN	9500
OB 160-SN	17600
OB 120-SF	3140
OB 140-SF	5880
OB 150-SF	9500
OB 160-SF	17600
OB 180-SF	24500
OB 200-SF	40180
OB 200W-SF	80360



Echt-Flex coupling	Allowable Torque (N·m)
NEF45W	441
NEF210W	2060
NEF340W	3330
NEF700W	6860
NEF45W	441
NEF210W	2060
NEF340W	3330
NEF700W	6860
NEF340W	3330
NEF700W	6860
NEH14W	13700
NEH20W	19600
NEF340W	3330
NEF700W	6860
NEH14W	13700
NEH20W	19600
NEH30W	29400
NEH41W	40200
NEH90W	88200

Model	Torque Capacity (N·m)
OB 120-PN	3140
OB 140-PN	5880
OB 150-PN	9500
OB 160-PN	17600
OB 180-PN	24500
OB 200-PN	40180
OB 200W-PN	80360
OB 120-PF	3140
OB 140-PF	5880
OB 150-PF	9500
OB 160-PF	17600
OB 180-PF	24500
OB 200-PF	40180
OB 200W-PF	80360
OB 120-S	3140
OB 140-S	5880
OB 150-S	9500
OB 160-S	17600
OB 180-S	24500



Echt-Flex coupling	Allowable Torque (N·m)
NEF340W	3330
NEF700W	6860
NEH14W	13700
NEH20W	19600
NEF30W	29400
NEH41W	40200
NEH90W	88200
NEF340W	3330
NEF700W	6860
NEH14W	13700
NEH20W	19600
NEF30W	29400
NEH41W	40200
NEH90W	88200
NEF340W	3330
NEF700W	6860
NEH14W	13700
NEH20W	19600
NEH30W	29400

Use these tables as guides to the Echt-Flex couplings, and select suitable couplings on the basis of the Echt-Flex couplings catalog.

Echt-Flex couplings cannot absorb axial displacement that is caused by an increase in temperature.

Adjust the installation so that T.I.R. is within 3/100 mm.

Use the spacer type as necessary. For further details, contact TSUBAKI.

## MODELS TB

### For Inching and Turning Drive Applications

#### Features

Compact turning and inching equipment combined with Cam Clutch and highly-reliable worm gear reducer as an auxiliary reducer.

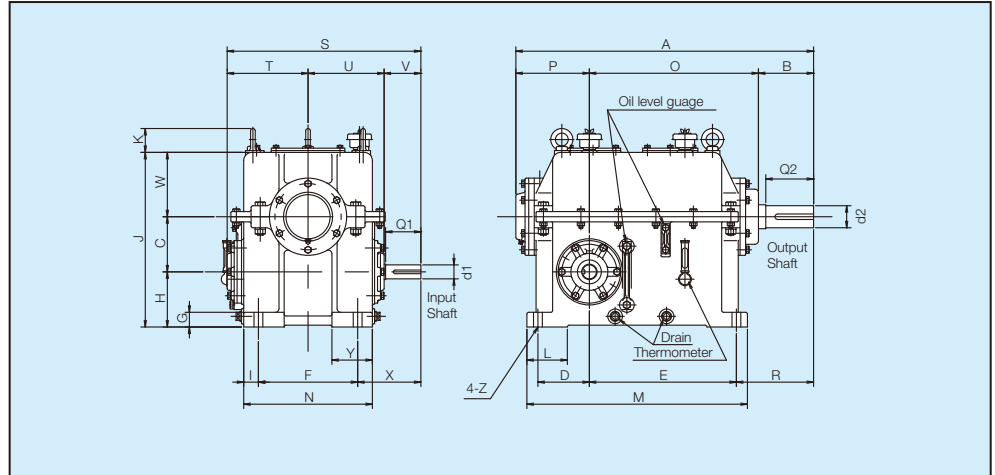

#### Capacities

Model	Torque Capacity (N.m)	Max. Overrunning (r/min)
TB 40-120	3140	1800
TB 60-140	5880	1500
TB 60-150	9500	1800
TB 70-160	17600	1500
TB 80-180	24500	1200

#### Applicable 6 pole motor and reduction ratios

Unit: kW

Model	Input Speed 1150 r/min								Input Speed 950 r/min							
	10	15	20	25	30	40	50	60	10	15	20	25	30	40	50	60
TB 40-120	5.5	3.7	3.7	2.2	2.2	1.5	1.5	0.75	5.5	3.7	2.2	2.2	2.2	1.5	1.5	0.75
TB 60-140	15	11	7.5	7.5	5.5	3.7	3.7	2.2	11	7.5	7.5	5.5	5.5	3.7	3.7	2.2
TB 60-150	15	11	7.5	7.5	5.5	3.7	3.7	2.2	11	7.5	7.5	5.5	5.5	3.7	3.7	2.2
TB 70-160	22	15	11	7.5	7.5	5.5	5.5	3.7	15	15	11	7.5	7.5	5.5	3.7	3.7
TB 80-180	22	-	15	-	11	7.5	7.5	5.5	22	-	15	-	11	7.5	5.5	5.5

#### Dimensions

Dimensions in mm

Model	A	B	C	D	E	F	G	H	I	J	K	L	M	N	O	P	R	S
TB 40-120	612	115	100	100	300	175	30	100	30	330	56	75	460	235	345	152	160	357
TB 60-140	810	150	150	140	400	270	40	150	40	475	65	110	600	350	460	200	210	527
TB 60-150	830	170	150	140	400	270	40	150	40	475	65	110	600	350	460	200	230	527
TB 70-160	890	190	175	150	430	330	45	180	45	565	76	120	640	420	490	210	250	607
TB 80-180	955	200	200	165	465	370	42	200	50	630	91	70	690	470	525	230	260	670

Model	T	U	V	W	X	Y	Z	Input Shaft			Input Shaft			Oil in Clutch Chamber (L)	Oil in Reducer Chamber (L)	Mass (kg)
								d1 (h7)	Key	Q1	d2 (m6)	Key	Q2			
TB 40-120	147	138	72	130	122	75	16	28	8×7×49 ℓ	68	40	12×8×99 ℓ	110	5.5	4	125
TB 60-140	220	207	100	175	172	110	24	38	10×8×73 ℓ	96	60	18×11×115 ℓ	130	17	10	290
TB 60-150	220	207	100	175	172	110	24	38	10×8×73 ℓ	96	70	20×12×135 ℓ	150	17	10	300
TB 70-160	252	242	113	210	190	130	30	45	14×9×87 ℓ	108	85	22×14×154 ℓ	170	25	15	500
TB 80-180	285	270	115	230	200	-	28	48	14×9×89 ℓ	110	100	28×16×161 ℓ	180	27	23	650

**Note:** The oil in the clutch chamber and in the reducer chamber are different. Be sure to use the recommended oil in each chamber. After you place an order, contact us to request a drawing for your approval.

For the TB series, a HY-VO chain coupling with a large elongation allowance for a shaft that connects the fan shaft and Cam Clutch output shaft can be provided together with the main unit. This HY-VO chain coupling is effective to absorb the axial displacement by heat up. For further details, please contact TSUBAKI.

## ■ INFORMATION FOR SELECTION

### Selection Procedure

1. Determine the mode of operation (indexing, overrunning, or backstopping).
2. Refer to the selection procedure corresponding to the mode of operation.

### Indexing

- a) When detailed load conditions can be calculated, apply formula A, and when not, apply formula B and check the torque on the Cam Clutch.
- b) Select the clutch by:
  - a) Design torque requirement
  - b) Maximum indexing cycles N
  - c) Feeding angle  $\theta$ 
    - $\theta \geq 90^\circ$ ....MI-S
    - $\theta < 90^\circ$ ....Other series
  - d)  $N \times \theta$ 
    - $N \times \theta \leq 20000$ ....MZ, PB, 200, MI, MX, PO, PG, PS
    - $N \times \theta \leq 50000$ ....MI-S
  - e) Bore size and installation method

**Note:** MX Series are designed especially for high-speed and high-accuracy indexing. Please consult TSUBAKI for proper selection.

Formula A:

$$T = \frac{J \cdot \theta \cdot N^2}{10380} + T_b$$

T: Loaded torque on Cam Clutch (N·m)  
 J: Inertia of load (kgf·m<sup>2</sup>) on Cam Clutch shaft  
 $\theta$ : Feeding angle (deg) on Cam Clutch shaft  
 N: Indexing cycles per minute (c/min)  
 T<sub>b</sub>: Brake torque calculated on Cam Clutch shaft (N·m)

Formula B:

$$T = \frac{9550 \cdot kW}{n} \cdot \frac{\ell_2}{\ell_1} \times 2.5$$

T: Loaded torque on Cam Clutch (N·m)  
 kW: Transmitted power (kW)  
 n: Speed of crank shaft (r/min)  
 $\ell_1$ : Length of crank  
 $\ell_2$ : Length of lever on Cam Clutch  
 2.5: Factor

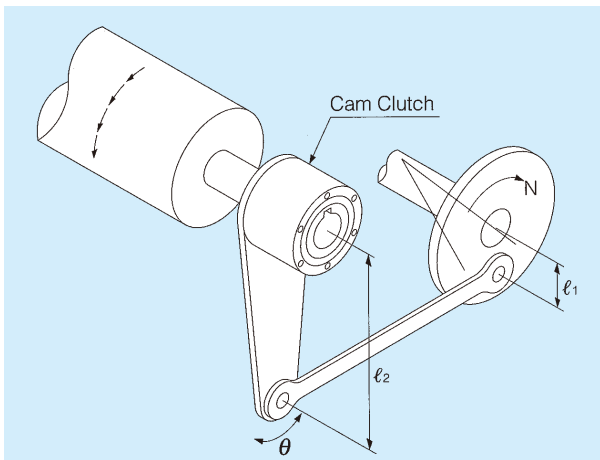

### Overrunning

- a) Calculate the torque on the Cam Clutch according to the following formula:

$$T = \frac{9550 \cdot kW}{N} \times SF$$

T: Loaded torque (N·m)  
 kW: Transmitted power (kW)  
 N: Speed of Cam Clutch shaft rotation (r/min)  
 SF: Service factor

- b) Select clutch by:

- a) Design torque requirement and service factor
  - b) Maximum overrunning speed
  - c) Bore and installation method
- If the SF is not known, use the peak torque with shock factor method.

Type of Load	SF
No shock load	1 – 1.5
Moderate shock load	1.5 – 2.5
Shock load	2 – 3
Heavy shock load	4 – 6

SF = Motor peak torque at starting x shock factor, K.  
 The shock factor K is obtained from the chart below by calculating inertia ratio. Use a shock factor of K = 1 when the inertia ratio is below 0.48.

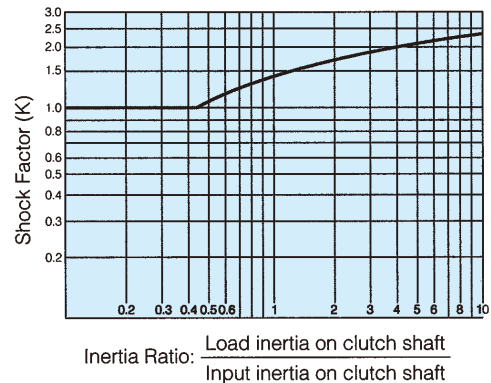

### Backstopping

Reference Table of backstopping torque/rotating speeds

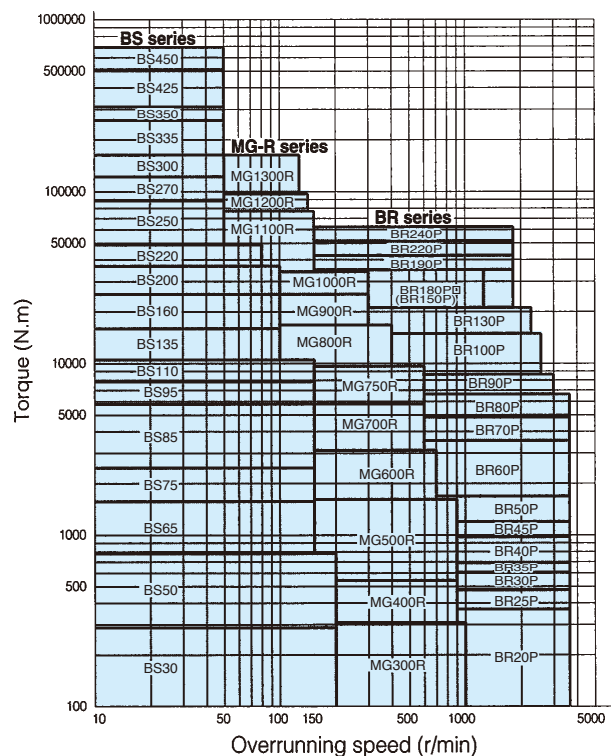

- a) Calculate the static torque reverse motion from the maximum load expected and multiply it by the service factor.
- b) Select the clutch by:
  - a) design torque requirement
  - b) max. overrunning speed
  - c) bore and installation method

**Notes:**

1. The BS series is designed especially for mounting on the main drive shaft of conveyors, where the rotational speed is rather low, while the MG-R series is designed for high-speed backstop applications.
2. Do not exceed the maximum torque of the clutch. Also, please consult TSUBAKI for special applications.

**For Belt Conveyors (Short inclined yard conveyor)**

Selection Procedure:

- (1) Calculate the power to move an empty belt and idlers: (P<sub>1</sub>)

$$P_1 = 0.06 \times f \times W \times V \times \frac{\ell + \ell_0}{367} \text{ (kW)}$$

- (2) Calculate the power to move a loaded belt horizontally: (P<sub>2</sub>)

$$P_2 = f \times Q_t \times \frac{\ell + \ell_0}{367} \text{ (kW)}$$

- (3) Calculate the power to move the load vertically: (P<sub>3</sub>)

$$P_3 = \frac{h \times Q_t}{367} \text{ (kW)}$$

- (4) Calculate the back stop power: (Pr)

$$Pr = P_3 - 0.7(P_1 + P_2) \text{ (kW)}$$

- (5) Calculate the back stop torque: (T)

$$T = \frac{9550 \times Pr}{N} \times SF \text{ (N·m)}$$

- (6) Select the proper clutch which satisfies the calculated backstop torque (T).

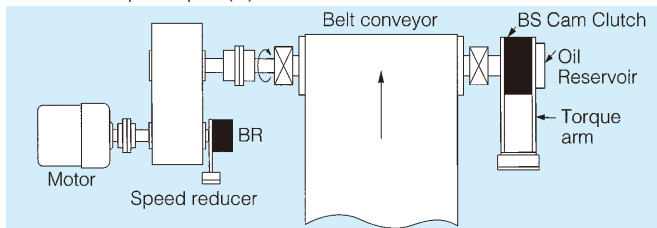

**Note:**

- f = Friction coefficient of rollers = 0.03 (normally used)
- W = Weight of moving parts of the conveyor in the unloaded condition (k g/m)

Use the values from the table below.

Width of Belt (mm)	400	450	500	600	750	900
Estimated Weight: W	22.4	28	30	35.5	53	63
Width of Belt (mm)	1050	1200	1400	1600	1800	2000
Estimated Weight: W	80	90	112	125	150	160

- V = Velocity of conveyor (m/min)
- Q<sub>t</sub> = Max. possible load (tonnes/hour)
- h = Total lift (m)
- ℓ = Horizontal distance between head pulley and tail pulley (m)
- ℓ<sub>0</sub> = Modification coefficient for ℓ = 49 m (normally used)
- N = Shaft speed (r/min) on which the clutch is mounted.
- SF = Service factor

Select service factor from table below:

SF	Service condition
1.5	Backstopping: Several times a day
2.0	Backstopping: More than several times a day

**For Bucket Elevators**

Selection Procedure:

$$(1) T = \frac{9.8 \times (L + D) \times Q_t \times D \times 1000}{120 \times V} \times SF \text{ (N·m)}$$

- (2) Select the proper clutch which satisfies the calculated backstop torque (T).

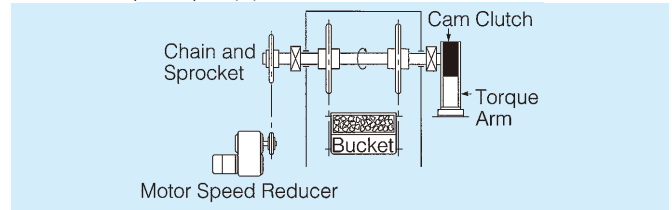

**Note:**

- L = Total lift (m)
- D = Pitch circle dia. of head sprocket (m)
- Q<sub>t</sub> = Possible maximum load (tons/hour)
- V = Velocity of conveyor (m/min)
- SF = Service factor

Use the values from the table below.

SF	Service condition
1.5	Several times a day
2.0	More than several times a day

**Note:**

For the conveyor types other than those in the above examples, calculate the backstop torque accordingly. **Always allow for the maximum possible load in your calculations, since backstopping often occurs when the conveyor is loaded above its normal loading capacity.**

**Motor Stall Torque Method**

Another method commonly used to select the proper backstop clutch size for conveyors is to use the motor name plate ratings plus the motor's ability to produce excess torque. Depending on the motor size, it may develop over 300% of rated torque. After stalling an overloaded conveyor can overload the backstop. For proper selection of the backstop, all facets of the mechanical system should be considered to ensure that the backstop is not the weakest link in the conveyor drive. If the motor breakdown torque is not known, refer to the motor manufacturer.

Selection is based on the following formula:

$$\text{Motor stall torque } T = \frac{\text{Transmission power of Motor kW} \times 9550}{\text{Shaft speed N (r/min)}} \times \frac{S}{100} \leq T_{\max}$$

S = Stall torque percentage

T<sub>max</sub> = Torque Capacity

**Note:**

1. Above selection procedures are for only BS series. As for other series, please consult Tsubaki.
2. We have BS-R series for demand of oil lubrication. Under the condition of few dust, we recommend BSEU series.

## LUBRICATION AND MAINTENANCE

The clutch should receive proper care and lubrication to ensure maximum long-life performance. See the maintenance instructions below.

### Recommended Oil

Brand	Overrunning or Backstop Applications		Indexing Applications
	In low speed applications (below 1/3 of maximum overrun speed) or ambient temperature from -10°C to 30°C	In high speed applications (over 1/3 of maximum overrun speed) or ambient temperature from 30°C to 50°C	
Shell Lubricants Japan	Turbo Oil T32 Rimula D Oil 10W Gelco ATF	Rimula D Oil 30	—
EMG Lubricants	DTE Oil Light Multipurpose ATF ATF220	Delvac 1330	—
ENEOS	FBK Turbine 32 Automatic D2 FBK Oil RO32 RIX Turbine32 ATF II (N)	FBK Oil RO68	—
Idemitsu Oil	Daphne Turbine Oil 32 Apolloil ATF-DX	Apolloil Dieselmotive S-330CF	Daphne Oil CR10
Cosmo Oil Lubricants	Cosmo Turbine Super 32 Cosmo Turbine 32 Cosmo ATF 2	Cosmo Diesel CF30	—
Sanwa Kasei Kogyo	—	—	Samic Arctic Oil Light

**Note:** Do not use oil that contains EP additives.

### Recommended Grease

Brand	Multi purpose including Li			
	General	BS BR-P Series	BB BSEU Series	BS-F Series
	(Consistency: NLGI No.2)	(Consistency: NLGI No.1)		
Shell Lubricants Japan	Alvania Grease S2 Sunlight Grease 2	Alvania Grease S1 Sunlight Grease 1	—	—
ENEOS	Multinoc Grease 2	Multinoc Grease 1	—	—
Kyodo Yushi	Unilube No.2	Multemp PS No.1	—	—
EMG Lubricants	—	—	Beacon 325	Beacon 325 Mobilgrease33
Cosmo Oil Lubricants	Dynamax Super No.2	Dynamax Super No.1	—	—

**Note:** Do not use grease that contains EP additives.

### Maintenance Instructions

Series	Lubricant	Maintenance
<b>MZ, BB, LD, PG, MDEU</b>	Grease	Pre-lubricated with grease. No lubrication maintenance required.
<b>200, PB</b>	Grease	Change the grease and clean the inside of the Cam Clutch every six months.
<b>TSS, TFS</b>	Oil	Change the oil and clean the inside of the Cam Clutch every six months.
<b>MG, MI, MI-S, MR</b>	Oil	Add oil every 100 hours. Change the oil and clean the inside of the Cam Clutch every three months.
<b>MX</b>	Oil	Change the oil and clean the inside of the Cam Clutch every 300 hours.
<b>MG-R</b>	Oil	Add oil every 300 hours. Change the oil and clean the inside of the Cam Clutch every three months.
<b>BR-P</b>	<b>Package type</b> Grease	Pre-lubricated with grease. Add grease every three months.
<b>BS</b>	<b>30 to 135</b> Grease	Pre-lubricated with grease. No lubrication maintenance required unless specified.
	<b>160 to 350</b> Grease	Periodic change of grease is necessary after 7,500 to 10,000 hours of operation. The actual operation time between changes should be decided after considering the operating conditions.
	<b>425, 450</b> Oil	Drain and clean inside of the Cam Clutch and inject new oil every 3 months.
<b>BS-R</b>	<b>65R to 450R</b> Oil	Periodically check the oil level on the oil gauge. Drain and clean inside of the Cam Clutch and inject new oil once a year.
<b>BS-F</b>	Grease	Pre-lubricated with grease. Drain and clean inside of the Cam Clutch and inject new grease once a year.
<b>BSEU</b>	Grease	Pre-lubricated with grease. No lubrication maintenance required unless specified.
<b>OB, TB</b>	Oil	Lubrication maintenance is necessary only once a year for normal use.
<b>MZEU12 ~ MZEU80</b>	Grease	From the grease nipple on the flange, the torque arm and the cover add grease every 3 months.
<b>MZEU90 ~ MZEU150</b>	Oil	Initially, replace oil after 10 hours of operation. Then replace it every 3 months. In a dirty environment, we recommend replacement every month.

## ■ LUBRICATION FOR THE CAM CLUTCH BOX

Selection of lubricant is an important factor to ensure long life performance.

Avoid the use of lubricants that include extreme pressure additives. The recommended lubricants are listed below.

All Cam Clutch Boxes are shipped without lubricant. Before use, fill the Cam Clutch Box with a recommended lubricant only to the line indicated on the oil gauge.

### Recommended lubricants: OB series

Brand	Lubricant Name
<b>Idemitsu Kosan</b>	Daphne Turbine Oil 46 to 68 Daphne Super Turbine Oil 46 to 68
<b>Shell Lubricants Japan</b>	Turbo Oil T46 to 68
<b>ENEOS</b>	FBK Turbine 46 to 68

Brand	Lubricant Name
<b>EMG Lubricants</b>	Mobil DTE Oil Medium Mobil DTE Oil Heavy Medium
<b>Cosmo Oil Lubricants</b>	Cosmo Turbine Super Oil 46 to 68
<b>BP</b>	BP Energol THB 46 to 68

### Recommended lubricants: TB series

The TB series requires two types of lubricants: one for the worm gear reducer and the other for the Cam Clutch. For the Cam Clutch, lubricants containing a large amount of extreme pressure additive such as gear oils (for the worm gear) are not appropriate. Pay special attention to use an appropriate one for each component.

Brand	Lubricant Name		
	Cam Clutch Side	Reducer Side	Recommended Grease
<b>Idemitsu Kosan</b>	Daphne Turbine Oil 46 to 68 Daphne Super Turbine Oil 46 to 68	Daphne Super Gear Oil 460	Daphne Eponex SR No.2
<b>Shell Lubricants Japan</b>	Turbo Oil T46 to 68	Omala Oil S2 G460	Alvania EP No.2
<b>ENEOS</b>	FBK Turbine 46 to 68	Bonnoc TS460	Epinox Grease AP2
<b>EMG Lubricants</b>	Mobil DTE Oil Medium Mobil DTE Oil Heavy Medium	Mobil Gear 600 XP 460	Mobilux EP2
<b>Cosmo Oil Lubricants</b>	Cosmo Turbine Super Oil 46 to 68	—	—

## ■ MAINTENANCE FOR THE BREU·MZEU SERIES

### Recommended Grease

Brand	Ambient Temperature	
	-5°C ~ +40°C	-40°C ~ +40°C
<b>EMG Lubricants</b>	—	Beacon 325
<b>Shell Lubricants Japan</b>	Alvania Grease S2	—
<b>BP</b>	Energol LS2	—
<b>TOTAL</b>	Multis 2	—
<b>Kyodo Yushi</b>	—	Multemp PS No.1

**Note:** Do not use Grease that contains EP additives.

E1~E7 options are supplied with bolts for installation, and the grease nipple.

### BREU series

BREU series Cam Clutches are pre-greased at the factory and should be re-greased every three months for both bearings after installation. Follow the procedure below.

1. Remove the set screw at the flange, torque arm or cover.
2. Inject equal amounts of grease into the bearing from the grease nipple. Refer to the grease volume table for the correct amount.
3. Run the Cam Clutch disengaged for from 20 to 30 minutes with the set screw removed. Excess of grease in the clutch area will flow out of the tapped holes. Be careful to avoid over greasing. Too much grease in the clutch will cause it to run hot, interfere with the clutch action, and may lead to mechanical damage.
4. Wipe off excess of grease and re-install the set screw.

### Grease Volume Table (g)

Model	Each bearing	Model	Each bearing	Model	Each bearing
BREU30	10	BREU55	30	BREU100	160
BREU35	10	BREU60	40	BREU130	260
BREU40	15	BREU70	50	BREU150	460
BREU45	20	BREU80	80		
BREU50	30	BREU90	90		

### BR-P series

BR-P series Cam Clutches are shipped pre-greased at the factory and should be re-greased every three months after installation. Follow the procedure below.

1. Remove the grease port plugs at the bearing and cam cage.
2. Inject equal amounts of grease into the cam cage and bearing. Refer to the Grease Volume Table for the correct amount.
3. Run the Cam Clutch disengaged for 30 minutes with the grease port plugs removed. Excess grease in the clutch area will flow out of the tapped holes. Be careful to avoid over greasing. Too much grease in the Cam Clutch will cause it to run hot, interfere with the clutch action, and may lead to mechanical damage.
4. Wipe off excess grease and re-install the grease port plugs.

### Grease Volume Table (g)

Model	Bearing	Cam Clutch	Model	Bearing	Cam Clutch	Model	Bearing	Cam Clutch
BR 20P	—	1.3	BR 50P	—	9.5	BR130P	—	80
BR 25P	—	2	BR 60P	—	13	BR150P	—	105
BR 30P	—	4	BR 70P	—	23	BR180P	20	25
BR 35P	—	4.2	BR 80P	—	25	BR190P	30	40
BR 40P	—	6	BR 90P	—	35	BR220P	30	45
BR 45P	—	6.5	BR100P	—	55	BR240P	50	50

## ■ LUBRICANT REPLENISHING METHOD FOR THE MG AND MR SERIES

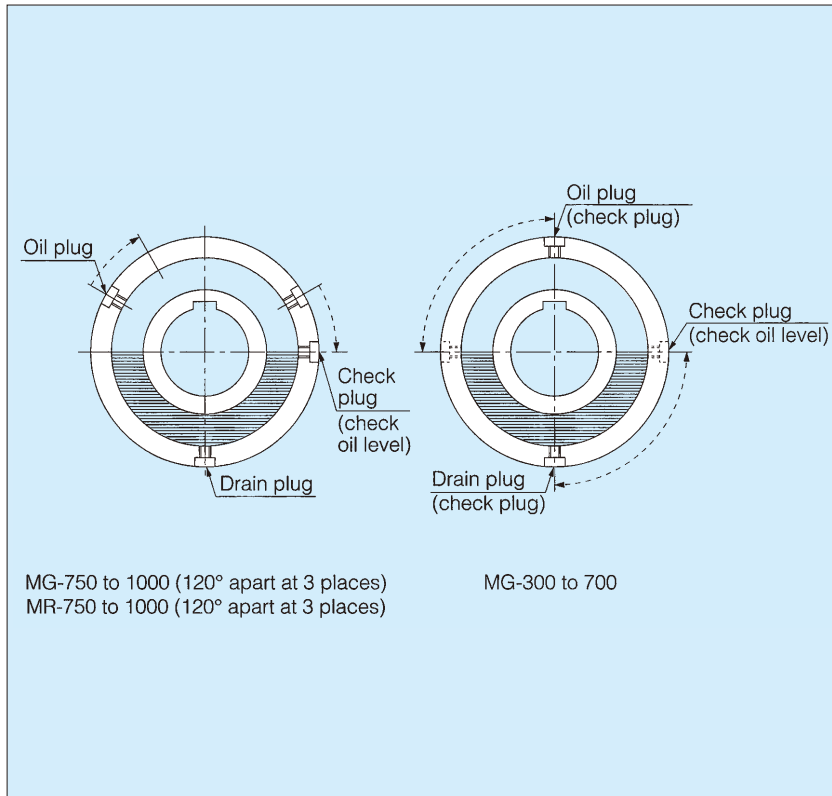

1. As a general rule, the level of the lubricant should be equal to the height of the center of the shaft for overrunning or back-stopping applications.
2. On every series, on the outer race, there are two to four plugs.
3. On models that have four plugs, place them so that one is at the top, one is at each side, and one is at the bottom. Then remove the plugs from the top and the sides and insert oil into the top hole until it begins to spill out from the side holes.
4. On models that have three plug, place one plug at the bottom and have the other two near the top. Remove the two upper plugs and insert oil into either side. Check the level by slowly turning the clutch until one of the upper plugs reaches the height of the center of the shaft.
5. On models that have only two plugs, place one plug at the top position, remove its plug, and then insert oil. Then rotate the clutch 90°C to check that the oil is filled up to the level of the center of the shaft.

## ■ LUBRICANT REPLENISHING METHOD FOR THE MI, MI-S AND MX SERIES

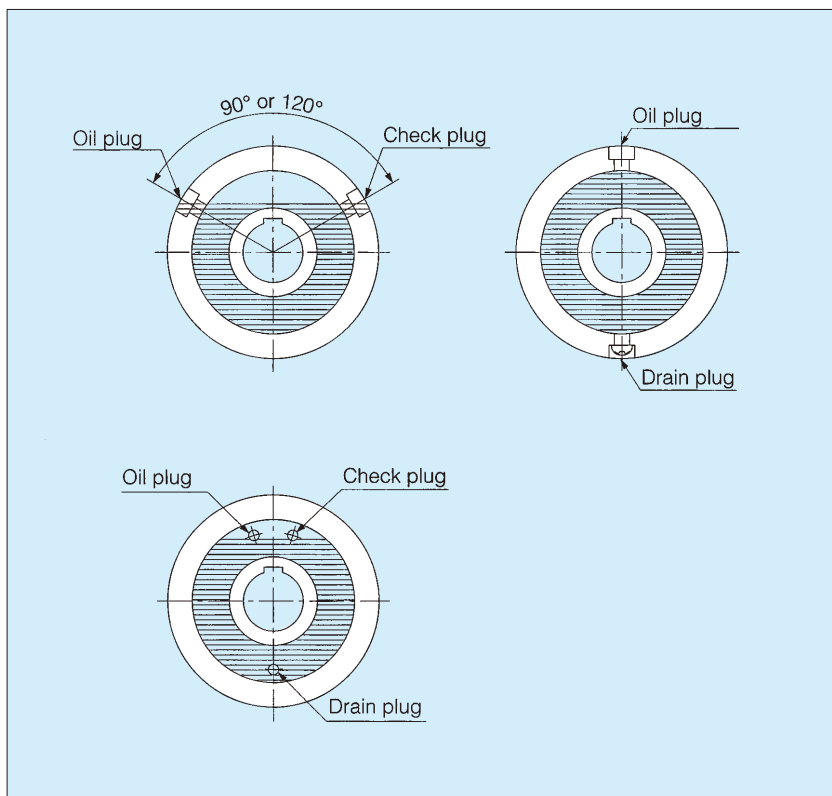

1. The level of the lubricant should be near the top of the inside of the Cam Clutch.
2. On the outside surface or on the side surface, there are oil plugs for oil filling and draining.
3. On models with three or four plugs on the outside surface, slightly turn the clutch and insert oil into one hole until oil begins to overflow out from one of its neighboring holes.
4. On models with two plugs, insert the tip of the oil feeder into the plug and fill completely with oil until it overflows.
5. On models with plugs on the side surface, place the two plugs lined up next to each other at the top, remove their plugs, and insert oil into one of them until oil begins to spill out from the other one.

## ■ LUBRICANT REPLENISHING METHOD FOR THE MG-R SERIES

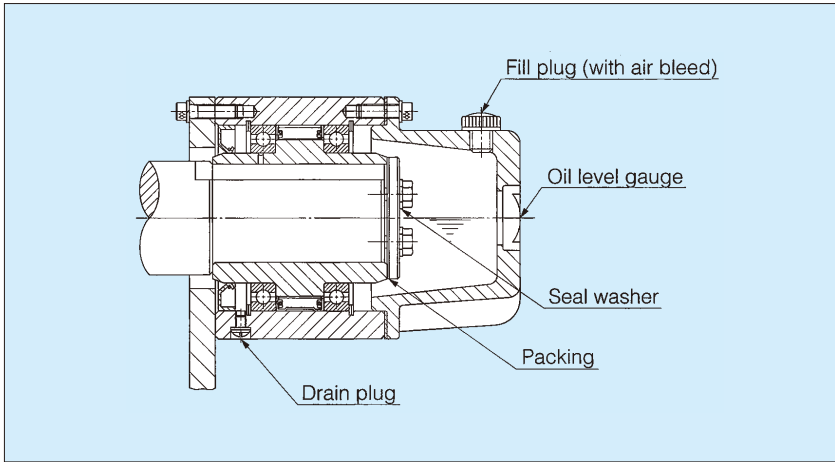

1. As a general rule, the level of the lubricant should be equal to the center of the shaft. Verify the level of the oil by the window-type oil level gauge built into the oil reserve tank.
2. On the outer race there are three or four oil plugs. Make one of these plugs the drain plug by installing the clutch so that the plug is at the very bottom. Since you insert oil through the oil plug on the oil reserve tank, install the oil reserve tank so that the oil plug is at the very top.

## ■ SPECIAL LUBRICATION METHODS

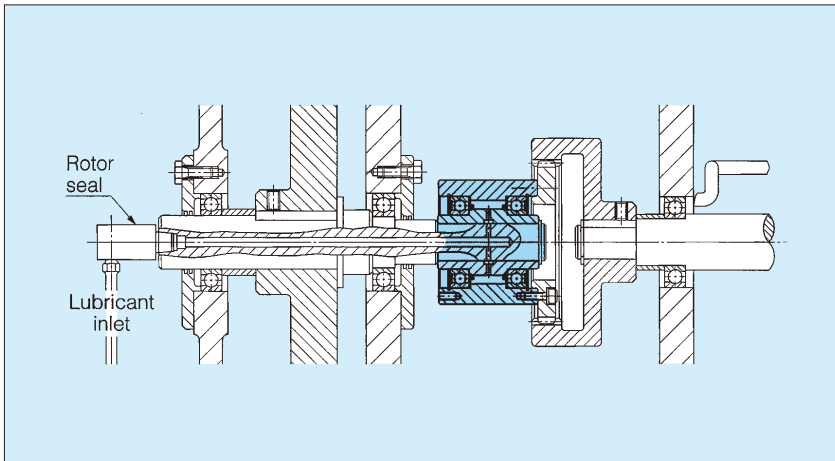

In some situations the Cam Clutch might be installed deep within your equipment making routine maintenance very difficult, or even impossible. The diagram on the left shows one such example.

In this example, a through hole is prepared through the shaft, and the oil is forced into the clutch through a rotor seal.

## ■ LIFE OF CAM CLUTCH

Regarding Cam Clutch life there are two conditions that must be considered:

1. Overrunning abrasion (wear) life
2. Engagement fatigue life

When assessing the expected lifetime of the cam clutch, it is important to consider the above conditions in relation to the actual application.

### 1. Overrunning abrasion (wear) life

\*When the Cam Clutch overruns:

On the contact surfaces of cams and races, skids occur in direct proportion to the overrunning rotational speed.

Therefore it is important to pay particular attention to abrasions at the contact points.

As the contact pressure by the weak spring force  $F$  is low, with sufficient lubrication, these parts will not wear or abrade in a short time.

Though it may vary depending on the lubricating condition, the right graph shows the calculated abrasion life, which has been properly lubricated based on the instructions provided in the catalog.

Abrasion life must be verified especially for applications involving high speed and long overrunning periods.

### 2. Engagement fatigue life

\*When the Cam Clutch engages:

At the contact surfaces of cams and races, the compression stress occurs in direct proportion to engagement torque.

Contact surface of inner/outer races move infinitely with respect to each engagement, while that of the cams are almost stable.

Therefore, the fatigue caused by this stress will then result in the surface pitting of cams.

Refer to the fatigue life curve, and check the expected life.

**Note:** In cases where the load applied to the Cam Clutch changes, or where vibrational loads are encountered, repeated torque loads can be applied during a single clutch engagement. The Variable Load Torque Graph shows the type of repetitive torque loads which can be applied to the Cam Clutch in these cases. Repeated torque loads during a single clutch engagement can have the effect of increasing the overall torque load, and this must also be considered when determining Cam Clutch service life.

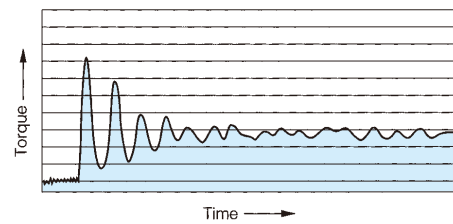
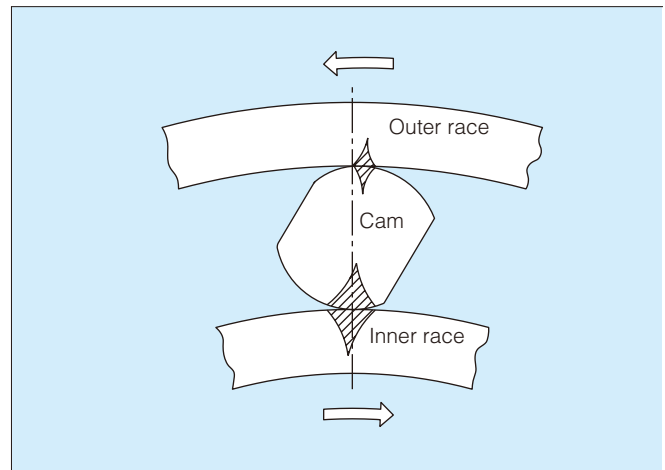

**Variable Load Torque Graph**

**Fatigue Service Life Graph**

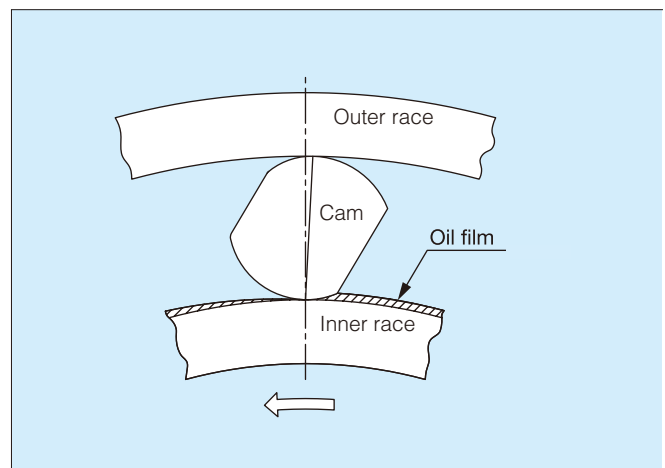

## ■ LIFE OF BR-HT SERIES CAM CLUTCH

The service life of previous TSUBAKI Cam Clutch was determined as the frictional service life during freerunning (clutch disengaged) and the fatigue service life of the engaged clutch.

However, with the BR Series, freerunning frictional service life is not a factor because there is no mechanical contact when the clutch is disengaged. As a result, service life is determined solely by the fatigue life of the engaged clutch.

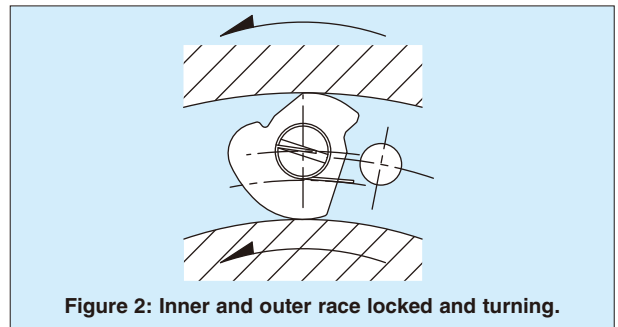
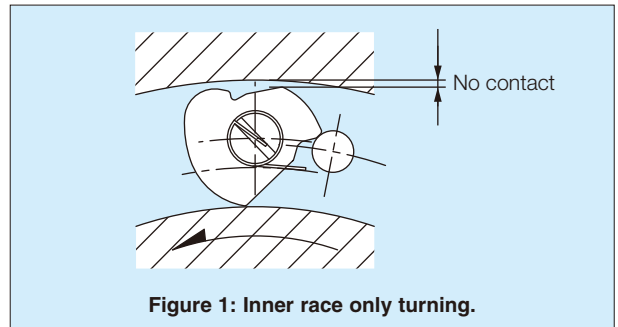
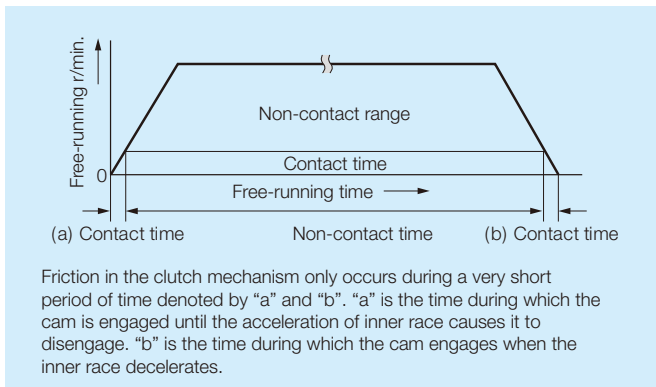

## ■ SERVICE LIFE OF CAM CLUTCH

### MZ Series

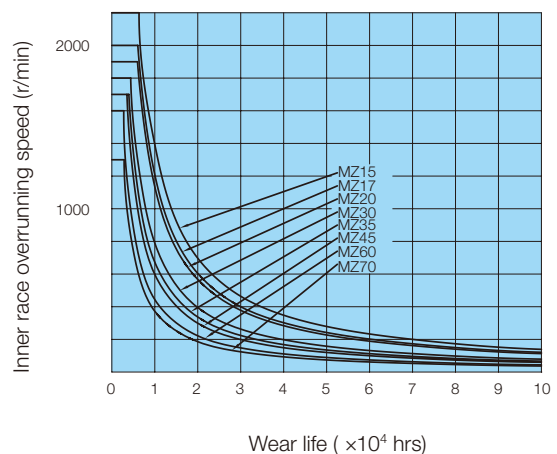
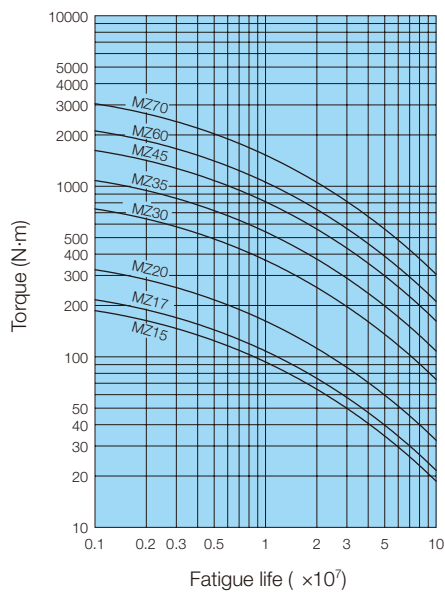

### TSS Series

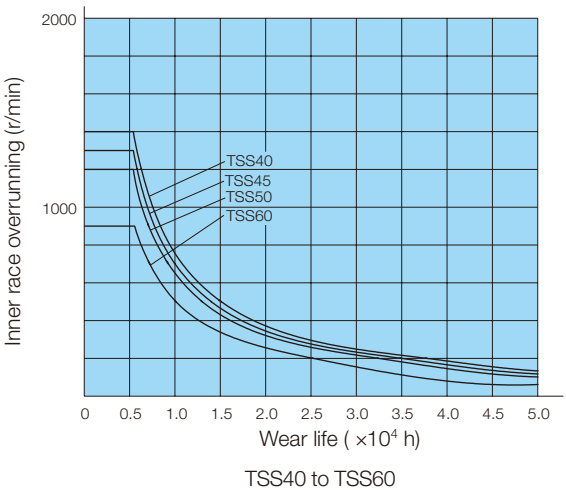
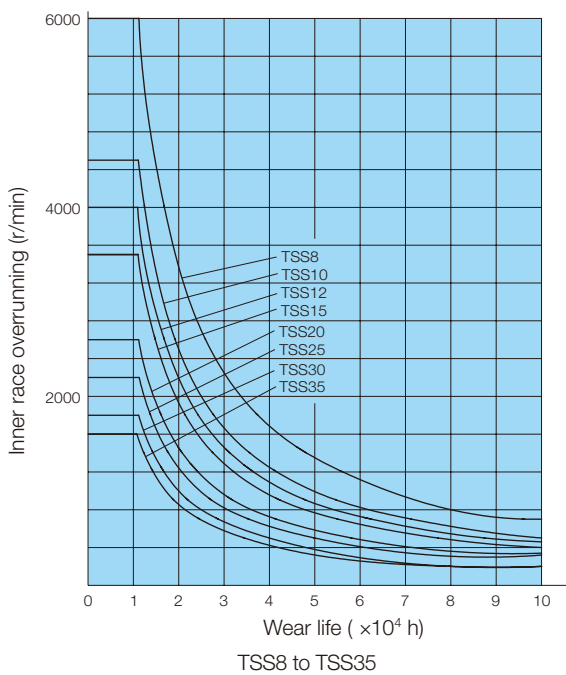
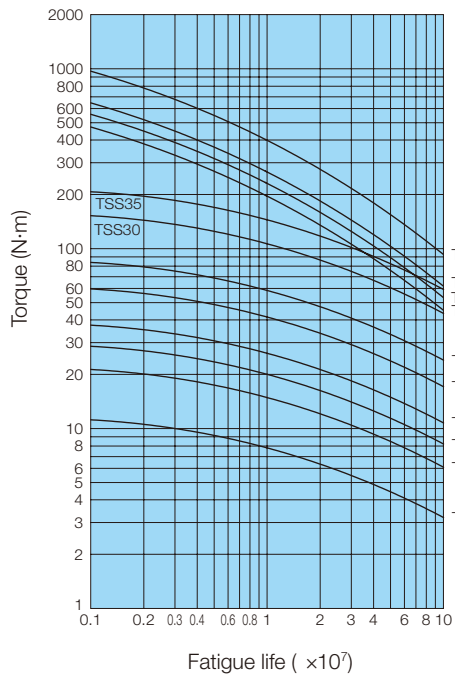

### 200 Series

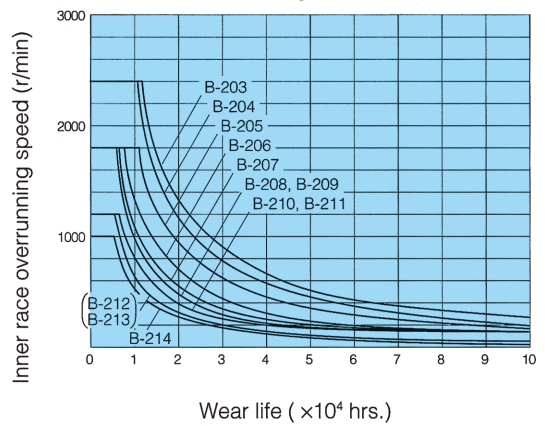
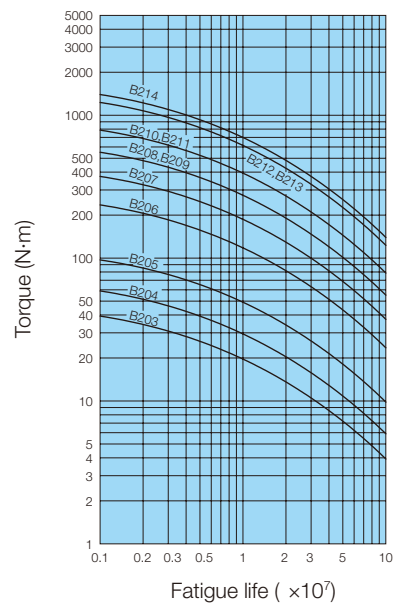

### BB Series

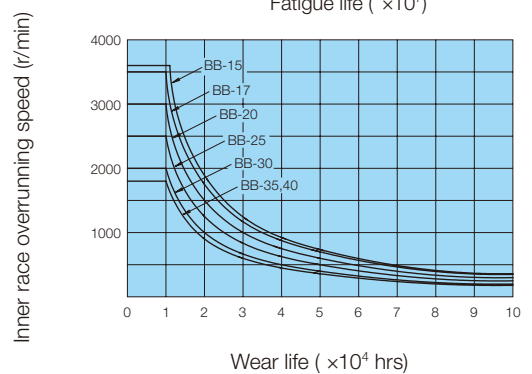
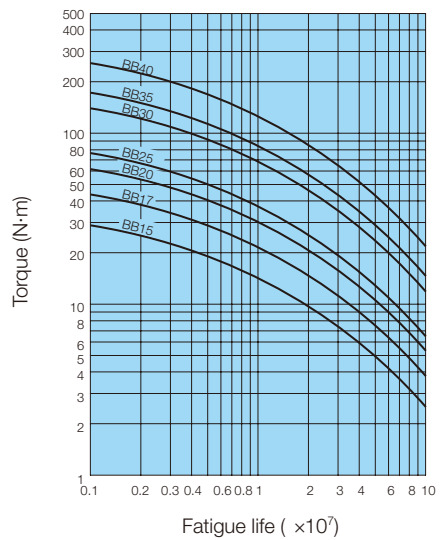

### TFS Series

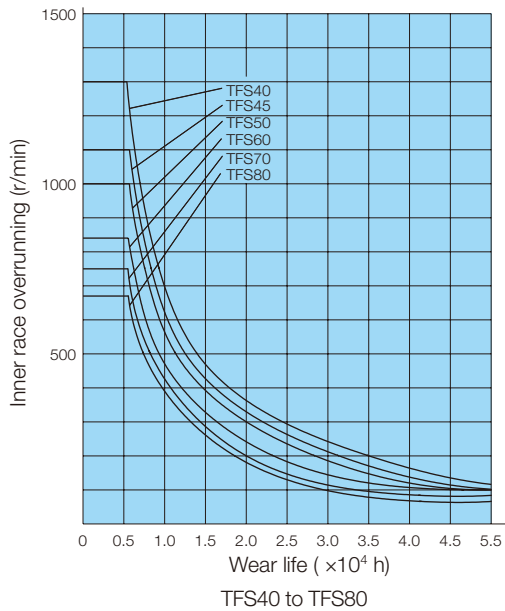
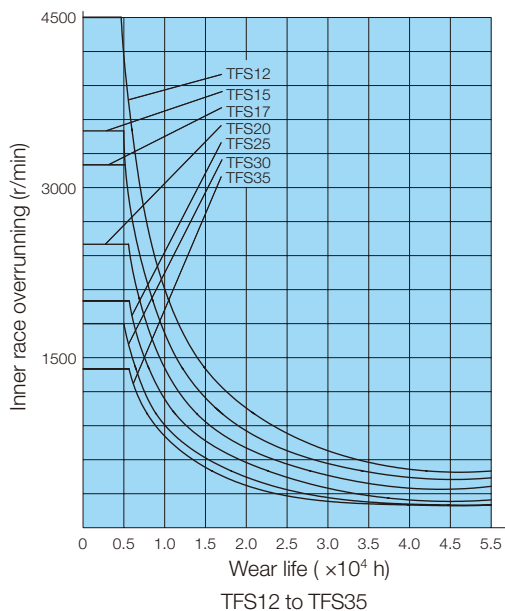
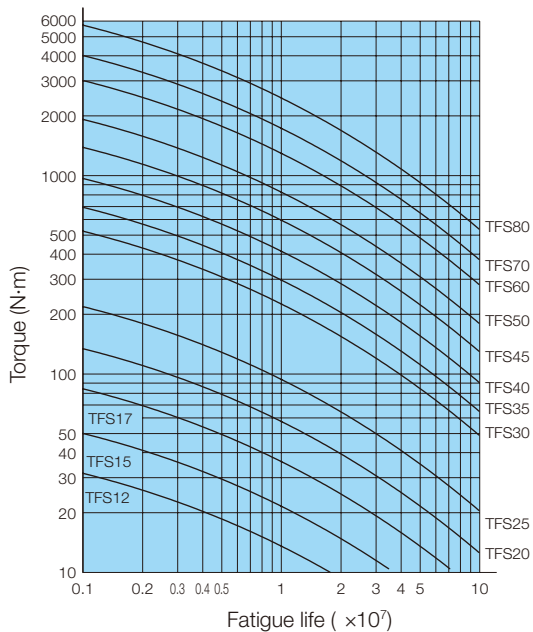

### PB Series

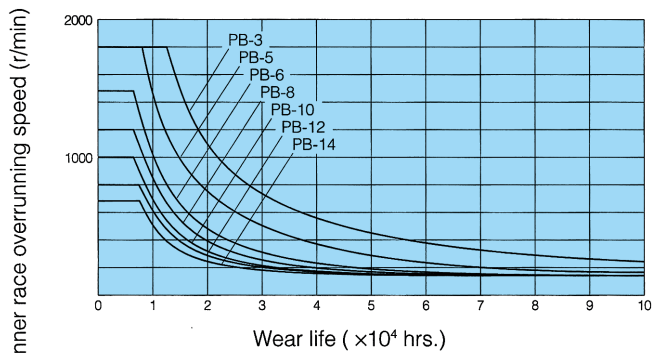
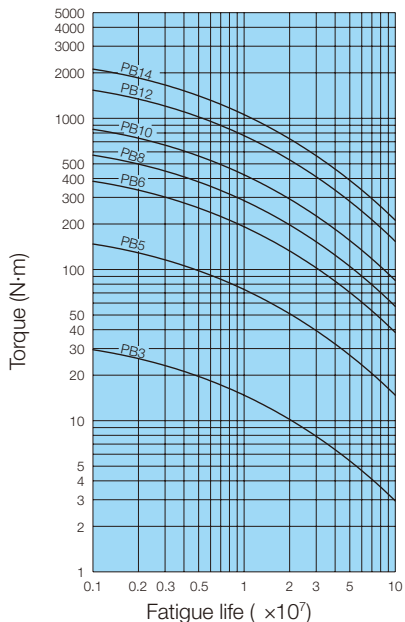

## BS Series

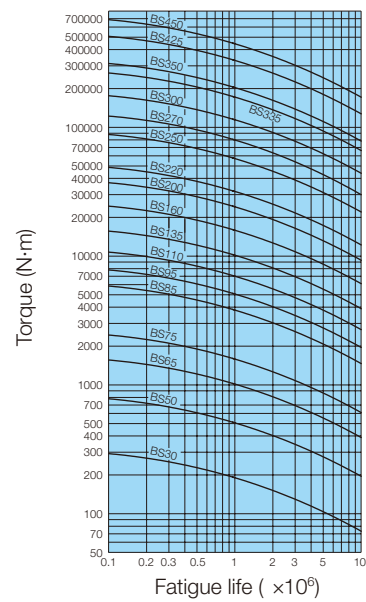
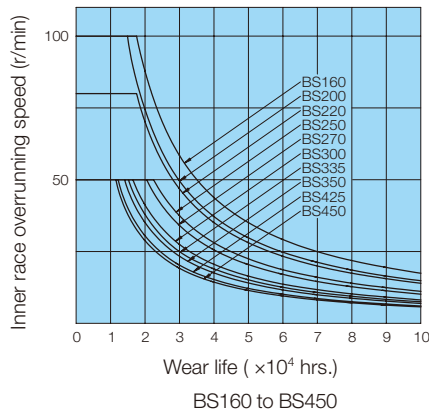
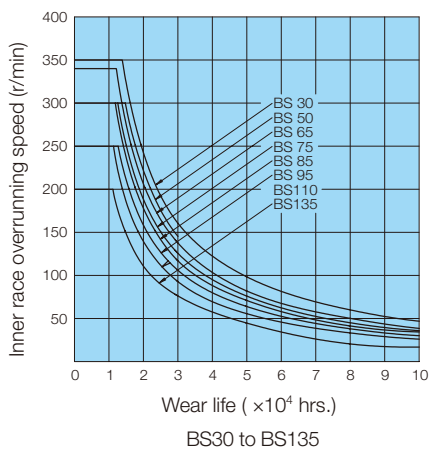

## BSEU Series

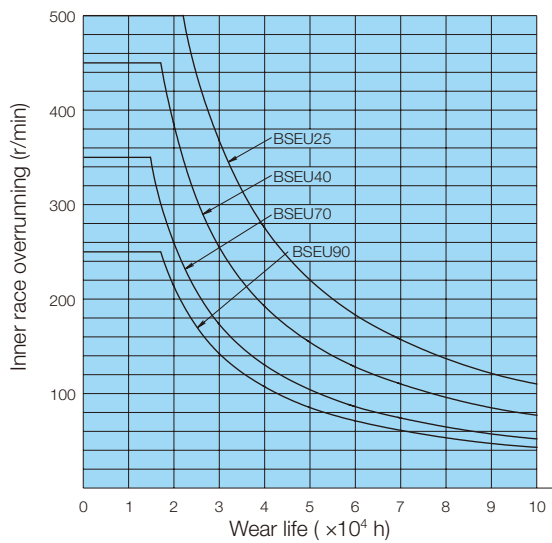
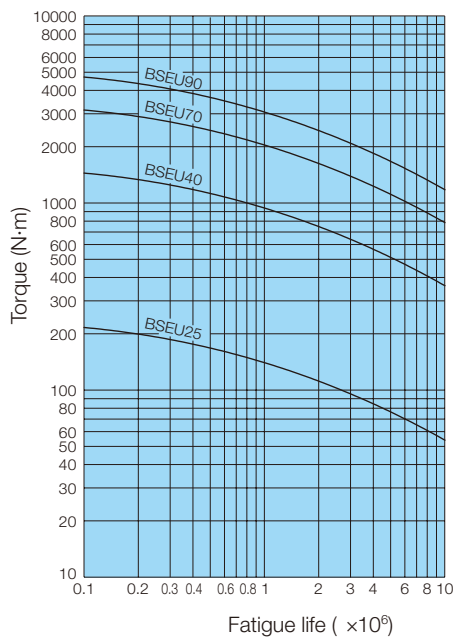

### MG MI MR Series

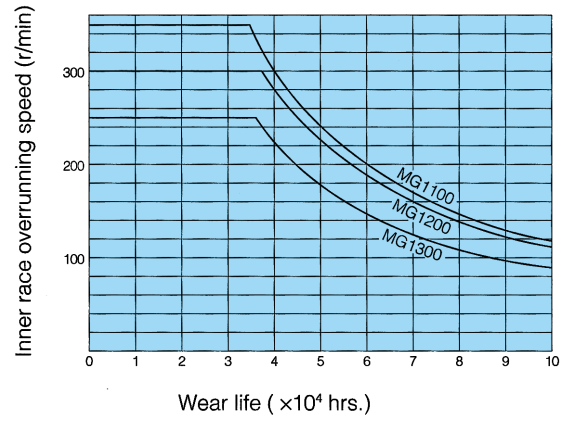
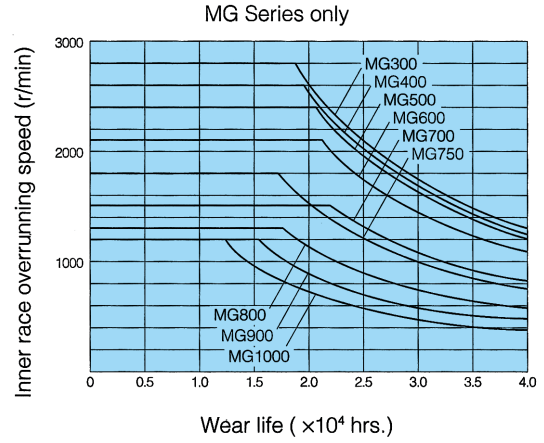
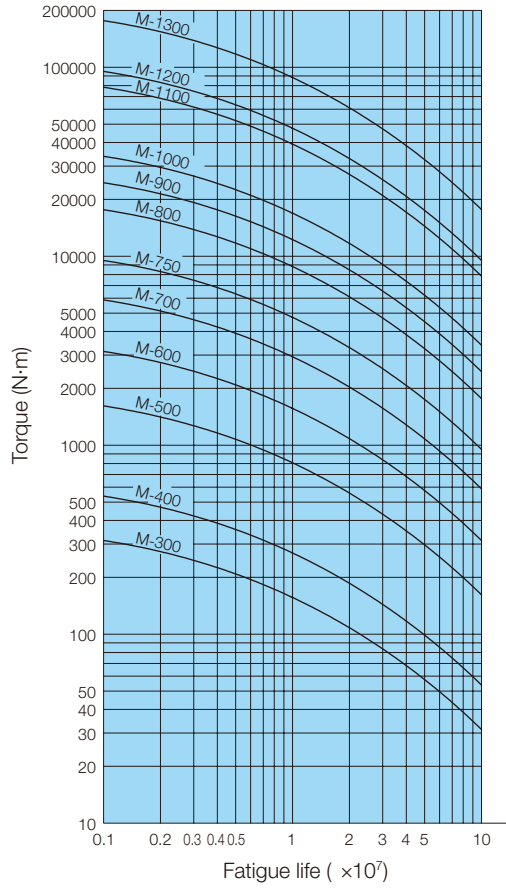

### LD Series

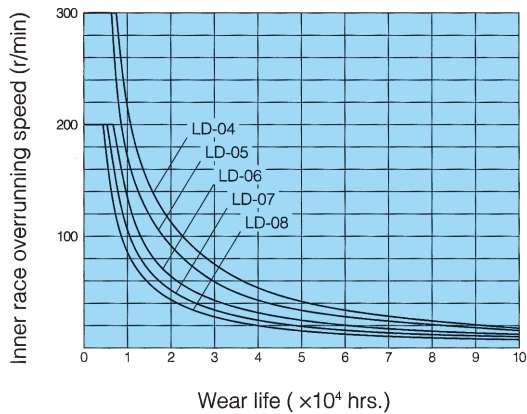
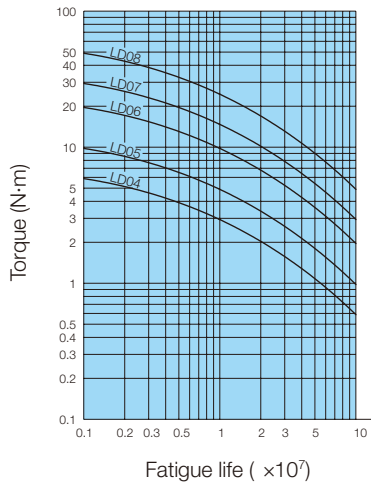

### MI-S Series

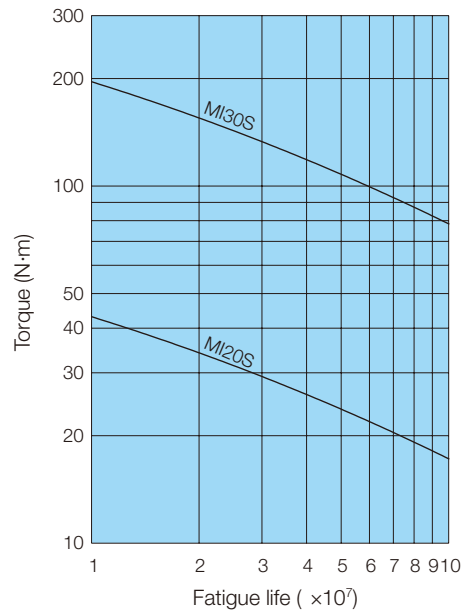

## MDEU Series

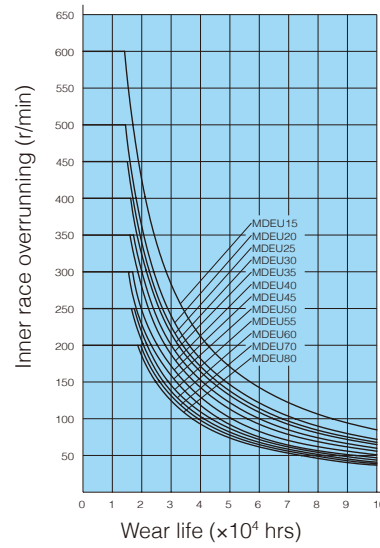
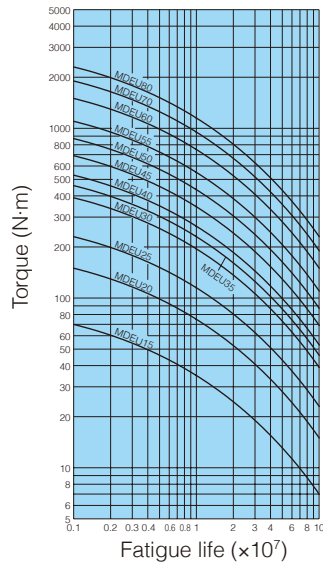

## MZEU Series

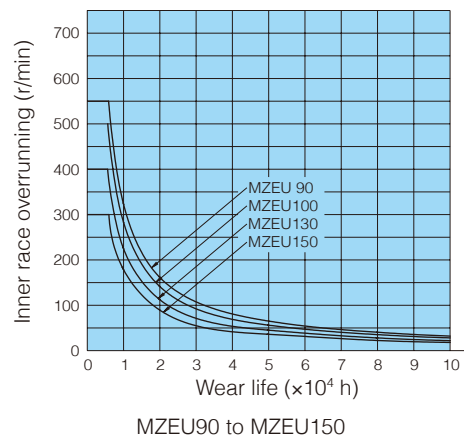
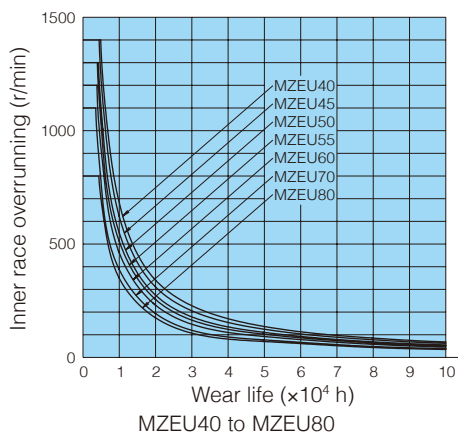
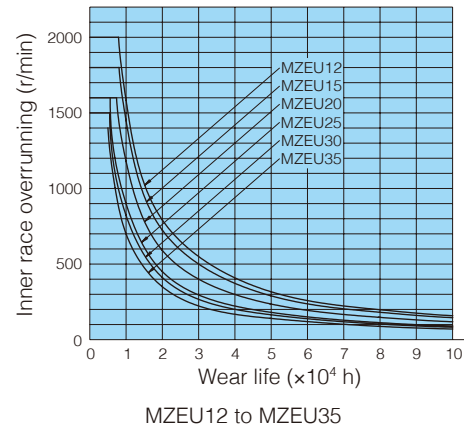
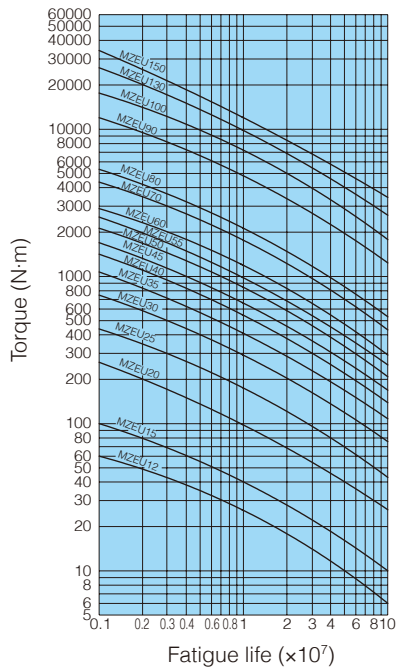

## Cam Clutch Box

### OB-ON

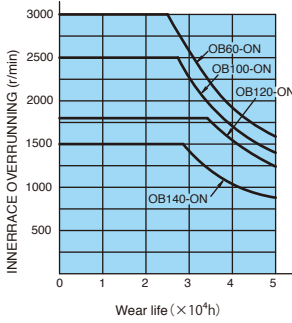

### OB-OF

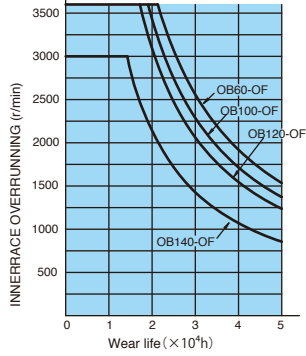

### OB-SN

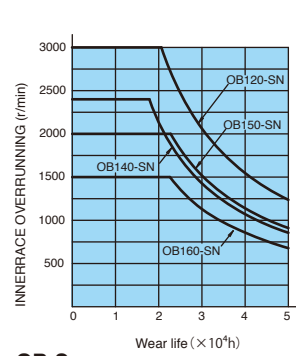

### OB-SF

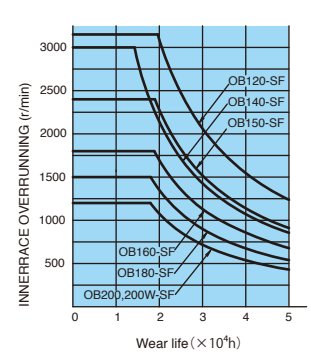

### OB-PN

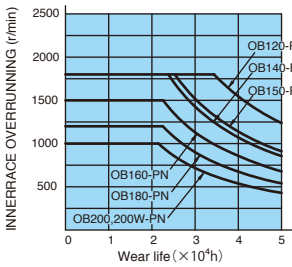

### OB-PF

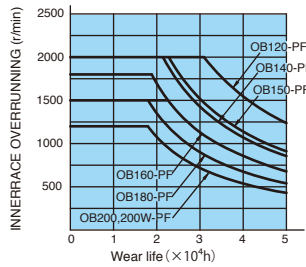

### OB-S

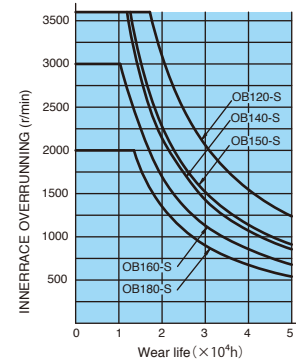

### TB

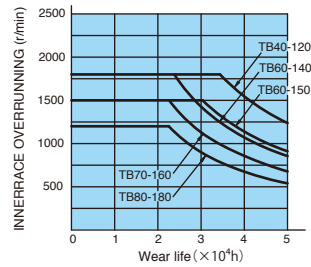

## Safety Guide



### WARNING

This mark indicates a situation where incorrect handling may cause hazardous conditions, resulting in death or severe injury.

- Guards must be provided on all power transmission and conveyor applications in accordance with provisions of ANSI/ASME B 15.1 1992 and ANSI/ASME B 20.1 1993 or other applicable standards. When revisions of these standards are published, the updated edition shall apply.
- When using any of the products described in this catalog, be sure to follow any applicable safety laws and regulations (such as the Labor Safety and Health Regulations).
- Follow the instructions below when installing, maintaining, or inspecting a product.
  1. Turn the power switch off.
  2. Do not store the device under equipment that may fall.
  3. Secure the movable parts of the equipment so as not to move.
  4. Wear clothing and protective gear suitable for the work.
- When performing a test operation or during periodic inspections, verify that the protective equipment is functioning properly.
- Always lock out power switch before installing, removing, lubricating or servicing a system that uses Cam Clutch products.
- If the Cam Clutch is used for repeated starting and stopping, make sure the strength of the supports for the Cam Clutch are sufficient.
- The capacity of your Cam Clutch may be effected by the accuracy of its set up, the amount of pressure exerted on it, wear on other parts in your system, or wear life of the Cam Clutch itself. Check the Cam Clutch at regular intervals and take any necessary safety precautions.
- When connecting or disconnecting Cam Clutch products, eye protection is required. Wear safety glasses, protective clothing, gloves and safety shoes.
- Cam Clutch maintenance and inspection should be performed only by qualified personnel with specialized knowledge.
- **Otherwise, fire, and injury may occur.**
- Operate the Cam Clutch according to the manufacturer's instructions.



### CAUTION

This mark indicates a situation where incorrect handling may cause hazardous conditions, resulting in medium or slight personal injury or property damage.

- Ensure that the end user of the device receives the appropriate instruction manual. Also make sure that the contents of the manual are carefully read before use.
- In the event that an instruction manual is not available, use the device name and model number to request one from the distributor where you purchased the device or from our sales office.
- Do not rearrange the device's components or perform additional work in order to modify the device in any way.
- Periodically check the product's functions and operations according to the instruction manual. If a function or operation is found to be inadequate, contact the distributor for repair.
- When disposing of the device, treat it as industrial waste.
- The device details described in this catalog are intended primarily for model selection. Before using the device, read the instruction manual thoroughly, and ensure the device is used correctly.

**Warranty:** TSUBAKIMOTO CHAIN CO. : hereinafter referred to as "Seller" Customer: hereinafter referred to as "Buyer"  
Goods sold or supplied by Seller to Buyer: hereinafter referred to as "Goods"

### 1. Warranty period without charge

Effective 18 months from the date of shipment or 12 months from the first use of Goods, including the installation of the Goods to the Buyer's equipment or machine - whichever comes first.

### 2. Warranty coverage

Should any damage or problem with the Goods arise within the warranty period, given that the Goods were operated and maintained according to the instructions provided in the manual, the Seller will repair and replace at no charge once the Goods are returned to the Seller. This warranty does not include the following:

- 1) Any costs related to removal of Goods from the Buyer's equipment or machine to repair or replace parts.
- 2) Cost to transport Buyer's equipment or machines to the Buyer's repair shop.
- 3) Costs to reimburse any profit loss due to any repair or damage and consequential losses caused by the Buyer.

### 3. Warranty with charge

Seller will charge for any investigation and repair of Goods caused by:

- 1) Improper installation by failing to follow the instruction manual.
- 2) Insufficient maintenance or improper operation by the Buyer.
- 3) Incorrect installation of the Goods to other equipment or machines.
- 4) Any modifications or alterations of Goods by the Buyer.
- 5) Any repair by engineers other than the Seller or those designated by the Seller.
- 6) Operation in an environment not specified in the manual.
- 7) Force Majeure or forces beyond the Seller's control such as natural disasters and injustices inflicted by a third party.
- 8) Secondary damage or problems incurred by the Buyer's equipment or machines.
- 9) Defective parts supplied or specified by the Buyer.
- 10) Incorrect wiring or parameter settings by the Buyer.
- 11) The end of life cycle of the Goods under normal usage.
- 12) Losses or damages not liable to the Seller.

### 4. Dispatch service

The service to dispatch a Seller's engineer to investigate, adjust or trial test the Seller's Goods is at the Buyer's expense.



---

## TSUBAKIMOTO CHAIN CO.

Japan	Tsubakimoto Chain Co.	<a href="https://tsubakimoto.com/">https://tsubakimoto.com/</a>
-------	-----------------------	-----------------------------------------------------------------

---

### Global Group Companies

#### AMERICAS

United States	U.S. Tsubaki Power Transmission, LLC	<a href="https://www.ustsubaki.com/">https://www.ustsubaki.com/</a>
Brazil	Tsubaki Brasil Equipamentos Industriais Ltda.	<a href="https://tsubaki.ind.br/">https://tsubaki.ind.br/</a>
Canada	Tsubaki of Canada Limited	<a href="https://tsubaki.ca/">https://tsubaki.ca/</a>

#### EUROPE

Netherlands	Tsubakimoto Europe B.V.	<a href="https://tsubaki.eu/">https://tsubaki.eu/</a>
France	Kabelschlepp France S.A.R.L.	<a href="https://tsubaki-kabelschlepp.com/fr-fr/">https://tsubaki-kabelschlepp.com/fr-fr/</a>
Germany	Tsubaki Deutschland GmbH Tsubaki Kabelschlepp GmbH	<a href="https://tsubaki.de/">https://tsubaki.de/</a> <a href="https://tsubaki-kabelschlepp.com/de-de/">https://tsubaki-kabelschlepp.com/de-de/</a>
Italy	Kabelschlepp Italia S.R.L.	<a href="https://tsubaki-kabelschlepp.com/it-it/">https://tsubaki-kabelschlepp.com/it-it/</a>
Spain	Tsubaki Ibérica Power Transmission S.L.	<a href="https://tsubaki.es/">https://tsubaki.es/</a>
United Kingdom	Tsubakimoto UK Ltd.	<a href="https://tsubaki.eu/">https://tsubaki.eu/</a>
Slovakia	Kabelschlepp-Systemtechnik, spol. s.r.o.	<a href="https://tsubaki-kabelschlepp.com/sk-sk/">https://tsubaki-kabelschlepp.com/sk-sk/</a>
Poland	Kabelschlepp Sp. z o.o.	<a href="https://kabelschlepp.pl/">https://kabelschlepp.pl/</a>

#### INDIAN OCEAN RIM

Singapore	Tsubakimoto Singapore Pte. Ltd.	<a href="https://tsubaki.sg/">https://tsubaki.sg/</a>
Australia	Tsubaki Australia Pty. Limited	<a href="https://tsubaki.com.au/">https://tsubaki.com.au/</a>
India	Tsubaki India Power Transmission Private Limited	<a href="https://en.tsubaki.in/">https://en.tsubaki.in/</a>
Indonesia	PT. Tsubaki Indonesia Trading	<a href="https://tsubaki.id/">https://tsubaki.id/</a>
Malaysia	Tsubaki Power Transmission (Malaysia) Sdn. Bhd.	<a href="https://en.tsubaki.my/">https://en.tsubaki.my/</a>
New Zealand	Tsubaki Australia Pty. Limited - New Zealand Branch	<a href="https://tsubaki.com.au/">https://tsubaki.com.au/</a>
Philippines	Tsubakimoto Philippines Corporation	<a href="https://en.tsubaki.ph/">https://en.tsubaki.ph/</a>
Thailand	Tsubakimoto (Thailand) Co., Ltd.	<a href="https://tsubaki.co.th/">https://tsubaki.co.th/</a>
Vietnam	Tsubakimoto Vietnam Co., Ltd.	<a href="https://tsubaki.net.vn/">https://tsubaki.net.vn/</a>

#### EAST ASIA

Republic of Korea	Tsubakimoto Korea Co., Ltd.	<a href="https://tsubakimoto-tck.co.kr/">https://tsubakimoto-tck.co.kr/</a>
Taiwan	Taiwan Tsubakimoto Trading Co., Ltd.	<a href="https://tsubakimoto.tw/">https://tsubakimoto.tw/</a>

#### CHINA

China	Tsubakimoto Chain (Shanghai) Co., Ltd.	<a href="https://www.tsubaki-sh.cn/">https://www.tsubaki-sh.cn/</a>
-------	----------------------------------------	---------------------------------------------------------------------